



Magnum Panels (MP) - AC/DC Distribution Enclosures



Owner's Manual

Disclaimer of Liability

The use of this manual and the conditions or methods of installation, operation, use and maintenance of the Magnum Panel is beyond the control of Magnum Energy, Inc. Therefore, this company does not assume responsibility and expressly disclaims liability for loss, damage, or expense, whether direct, indirect, consequential or incidental, arising out of or anyway connected with such installation, operation, use, or maintenance.

Note as well that while every precaution has been taken to ensure the accuracy of the contents of this manual, the specifications and product functionality may change without notice. Magnum Energy, Inc. assumes no responsibility for errors or omissions.

Restrictions on Use

Magnum Energy, Inc. does not recommend the use of any of its products with life support systems, life saving, or other medical equipment or devices designated as "critical" by the U.S. FDA where failure or malfunction of the Magnum Energy product can be reasonably expected to cause failure of the life support device, or to significantly affect its safety or effectiveness. Using Magnum Energy products with this particular equipment is at your own risk.

Copyright Notice

Copyright © 2011 by Magnum Energy, Inc. All rights reserved. Permission to copy, distribute and/or modify this document is prohibited unless express written permission from Magnum Energy, Inc. is provided.

Contact Information

Magnum Energy, Inc.
2211 West Casino Rd.
Everett, WA 98204
Phone: 425-353-8833
Fax: 425-353-8390
Web: www.MagnumEnergy.com

Statement of Appreciation

From all of us at Magnum Energy -

Thank you for purchasing this Magnum Panel (MP).

We understand that you have many purchasing options in the marketplace, and are pleased that you have decided on a Magnum Energy product. This MP enclosure was proudly designed, assembled and tested in the United States at our Everett, Washington facility.

At Magnum, we are committed to providing you with quality products and services; we hope that your experience with us is pleasant and professional.

Magnum Energy® is a registered trademark of Magnum Energy, Inc.

Table of Contents

1.0	Safety Information	v
1.1	Safety Symbols	v
1.2	General Safety	v
1.3	Battery Safety	vi
2.0	Introduction	1
2.1	MP Series Overview	1
2.2	Regulatory Compliance	6
2.3	MP External Components	7
2.4	MP Internal Components.....	9
3.0	Installation	17
3.1	Pre-Installation.....	17
3.2	Location	22
3.3	Preparing the MP Enclosure and Inverter.....	25
3.4	Mounting the MP/Inverter System	31
3.5	Wiring the MP Enclosures.....	36
3.6	AC Wiring	38
3.7	DC Wiring	44
3.8	Wiring Accessories	51
3.9	Removing the NEUTRAL-GROUND Wire	53
3.10	Removing the NEGATIVE-GROUND Busbar	54
3.11	MP/Inverter System Grounding.....	55
3.12	Installation Checklist	59
3.13	Functional Test	61
3.14	Attaching Front Covers	66
3.15	Master/Slave Identification Label Set.....	67
4.0	Wiring Diagrams	68
5.0	Operation	93
5.1	Inverter DC Disconnect Breaker	94
5.2	Inverter AC Input Breaker.....	94
5.3	Bypass Switch Assembly	94
Appendix A - Misc. Info and Optional Equipment/Accessories	97	
A1	Installing the Charge Controller Bracket.....	97
A2	Installing a Battery Monitor	100
A3	Inverter Hood Info	102
A4	Router Bracket Info	102
A5	Knockout Plate	104
A6	Installing Optional DC Breakers	105
A7	Installing Optional AC Load Breakers	107
A8	Aligning Front Breaker Face Plate	108
A9	Optional Router Front Top Cover	109
A10	Installing Lightning Arrestors.....	110
Appendix B - Warranty and Service	112	
B1	Limited Warranty	112
B2	How to Receive Repair Service.....	112

List of Figures

Figure 2-1a, MP SL-30D as Shipped	2
Figure 2-1b, MP SL-30D with Field Installed Options	2
Figure 2-2a, MP SL-60S as Shipped	3
Figure 2-2b, MP SL-60S with Field Installed Options	3
Figure 2-3a, MP SH-30D as Shipped	4
Figure 2-3b, MP SH-30D with Field Installed Options	4
Figure 2-4a, MP DH-30D as Shipped	5
Figure 2-4b, MP DH-30D with Field Installed Options	5
Figure 2-5, MP SL and MP SH External Components	7
Figure 2-6, MP DH External Components	8
Figure 2-7, MP SL-30D Internal Components	12
Figure 2-8, MP SL-60S Internal Components	13
Figure 2-9, MP SH-30D Internal Components	14
Figure 2-10a, MP DH-30D (AC Side) Internal Components	15
Figure 2-10b, MP DH-30D (DC Side) Internal Components	16
Figure 3-1, Parts Included - MP SL and MP SH Models	18
Figure 3-2, Parts Included - MP DH Models	18
Figure 3-3, MP Series Simplified Parallel-Stacked Installation Diagram	20
Figure 3-4, MP Series Simplified Series-Stacked Installation Diagram	21
Figure 3-5, System Dimensions (Single Enclosure)	23
Figure 3-6, System Dimensions (Dual Enclosure)	24
Figure 3-7, Front Cover Screws to Remove	25
Figure 3-8, Removing Front Cover - Single Enclosure	26
Figure 3-9, Removing Front Covers - Dual Enclosure	26
Figure 3-10, Conduit/Wire Routing	27
Figure 3-11, Removing Knockouts	28
Figure 3-12, Connect and Separate Inverter AC Wires	28
Figure 3-13, MP SL/MP SH Dimensions and Knockout Location/Sizes	29
Figure 3-14, MP DH Dimensions and Knockout Location/Sizes	30
Figure 3-15a, Mounting the MP Single Enclosure	31
Figure 3-15b, Mounting Inverter - MP Single Enclosure	32
Figure 3-15c, Mounting Inverter Hood - MP Single Enclosure	32
Figure 3-16a, Mounting the MP Dual Enclosure (DC Side)	33
Figure 3-16b, Mounting the MP Dual Enclosure (AC Side)	33
Figure 3-16c, Connecting the Two Sides Together - MP Dual Enclosure	34
Figure 3-16d, Mounting First Inverter - MP Dual Enclosure	34
Figure 3-16e, Mounting Second Inverter - MP Dual Enclosure	35
Figure 3-16f, Mounting the Inverter Hoods - MP Dual Enclosure	35
Figure 3-17, MP SL-30D and MP SH-30D AC Wiring Connections	41
Figure 3-18, MP SL-60S AC Wiring Connections	42
Figure 3-19, MP DH-30D AC Wiring Connections	43
Figure 3-20, DC Hardware Connections	46
Figure 3-21, DC Wiring Connection Points for MP SL Models	48
Figure 3-22, DC Wiring Connection Points for MP SH-30D	49
Figure 3-23, DC Wiring Connection Points for MP DH-30D (DC Side)	50
Figure 3-24, REMOTE Communication Cable (300V Rated)	51
Figure 3-25, NETWORK Communication Cable (300V Rated)	51
Figure 3-26, Extension Cable (300V Rated)	51
Figure 3-27, Accessory Wiring Using 300 Volt Communications Cables	52
Figure 3-28, Removing the NEUTRAL-GROUND Wire	53
Figure 3-29, Removing the NEGATIVE-GROUND Busbar	54
Figure 3-30, Grounding System for Inverter with MP Enclosure	55
Figure 3-31, Single Connection to DC Ground Rod (Method 1)	56
Figure 3-32, Multiple Connections to DC Ground Rod (Method 2)	57
Figure 3-33, Multiple Connections to DC Ground Rod (Method 3)	57
Figure 3-34, DC Voltage Checks - Single Enclosures	61
Figure 3-35, DC Voltage Checks - Dual Enclosures (DC Side)	61
Figure 3-36, AC Voltage Checks - MP SL-30D and MP SH-30D Models	63
Figure 3-37, AC Voltage Checks - MP SL-60S Models	64
Figure 3-38, AC Voltage Checks - MP DH-30D (AC Side) Models	65
Figure 3-39, Attaching Front Cover - MP SL/MP SH Models	66

Figure 3-40, Attaching Front Covers - MPDH Models	66
Figure 3-41, Applying Master/Slave Identification Labels.....	67
Figure 4-1, Inverter AC Input and Output Wiring Diagram - MS4024.....	69
Figure 4-2, Inverter AC Input and Output Wiring Diagram - MS-PAE Series.....	70
Figure 4-3a, MPSSL-30D Inverter AC Wiring	71
Figure 4-3b, MPSSL-30D External AC Wiring.....	72
Figure 4-3c, MPSSL-30D DC Wiring	73
Figure 4-3d, MPSSL-30D Communications Wiring.....	74
Figure 4-3e, MPSSL-30D Full System Wiring Diagram	75
Figure 4-4a, MPSSL-60S Inverter AC Wiring	76
Figure 4-4b, MPSSL-60S External AC Wiring.....	77
Figure 4-4c, MPSSL-60S DC Wiring	78
Figure 4-4d, MPSSL-60S Communications Wiring	79
Figure 4-4e, MPSSL-60S Full System Wiring Diagram	80
Figure 4-5a, MPSSH-30D Inverter AC Wiring	81
Figure 4-5b, MPSSH-30D External AC Wiring	82
Figure 4-5c, MPSSH-30D DC Wiring	83
Figure 4-5d, MPSSH-30D Communications Wiring	84
Figure 4-5e, MPSSH-30D Full System Wiring Diagram	85
Figure 4-6a, MPDPH-30D Inverter AC Wiring	86
Figure 4-6b, MPDPH-30D External AC Wiring.....	87
Figure 4-6c, MPDPH-30D Inverter DC Wiring	88
Figure 4-6d, MPDPH-30D External DC Wiring	89
Figure 4-6e, MPDPH-30D Communications Wiring.....	90
Figure 4-6f.1, MPDPH-30D Full System Wiring Diagram (AC Side).....	91
Figure 4-6f.2, MPDPH-30D Full System Wiring Diagram (DC Side).....	92
Figure 5-1, MP Functional Diagram.....	93
Figure 5-2, 60A Bypass Switch Operation (MPSSL-30D and MPSSL-60S)	95
Figure 5-3, 125A Bypass Switch Operation (MPSSH-30D and MPDPH-30D).....	96
Figure A1-1, Charge Controller Bracket - Physical Dimensions.....	97
Figure A1-2, Charge Controller Bracket Mounting Holes	98
Figure A1-3, Holes Used to Mount Bracket on MP Enclosure.....	99
Figure A2-1, Accessing the DC Shunt	100
Figure A2-2, Wiring the ME-BMK-NS.....	100
Figure A2-3, Mounting the Sense Module	101
Figure A2-4, Close-up of Wiring the Sense Module and DC Shunt	101
Figure A3-1, Inverter Hood Dimensions	102
Figure A4-1, Router Bracket Dimensions	102
Figure A4-2, Router Bracket Kit	103
Figure A4-3, Mounting the Router Bracket and Router.....	103
Figure A5-1, Attaching Knockout Plate.....	104
Figure A5-2, Knockout Plate Dimensions and Knockouts.....	104
Figure A6-1, Installing DIN Rail-Mounted DC Breakers	105
Figure A6-2, Installing Back-Mounted DC Breakers.....	106
Figure A6-3, Wiring DC Breakers to Controller/PV Array	106
Figure A7-1, Installing AC Load Breakers - Single MP Enclosure	107
Figure A7-2, Installing AC Load Breakers - Dual MP Enclosure	107
Figure A8-1, Removing the Front Breaker Face Plate	108
Figure A9-1, Router Front Top Cover	109
Figure A10-1, Installing Lightning Arrestor on MP Enclosure	110
Figure A10-2, Wiring Lightning Arrestor to MP Enclosure.....	111

List of Tables

Table 3-1, Torque Values for Dual Hole Busbars	37
Table 3-2, Torque Values for 3/8-16 Bolts	37
Table 3-3, Torque Values for Terminal Screws on AC Input Breakers	37
Table 3-4, MP AC Wire Kits.....	39
Table 3-5, Minimum AC Wire Size for AC Output Breaker.....	40
Table 3-6, AC Grounding Electrode Conductor Sizing	56
Table 3-7, Equipment Grounding Conductor Sizing	58
Table 4-1, MP Wiring Diagrams.....	68
Table A-1, Mounting Holes Used for Charge Controllers	97

1.0 Safety Information

1.0 Safety Information

IMPORTANT SAFETY INSTRUCTIONS

This manual contains important safety instructions that must be followed during the installation and operation of this product. Before using the Magnum Panel (MP), read all instructions and cautionary markings on: (1) the MP enclosure, (2) the inverter/charger, and (3) the batteries, as well as the individual manuals provided for each component of the system.

These installation instructions are for use by qualified personnel only. Do not perform any installation or servicing other than that specified in this owner's manual unless qualified to do so. Incorrect installation or servicing may result in a risk of electric shock, fire, or other safety hazard.

1.1 Safety Symbols

The following safety symbols have been placed throughout this manual to indicate dangerous conditions and important safety instructions.



WARNING: This symbol indicates that failure to take a specified action could result in physical harm to the user.



CAUTION: This symbol indicates that failure to take a specified action could result in damage to the equipment.



Info: This symbol indicates information that emphasizes or supplements important points of the main text.

1.2 General Safety

- All electrical work must be performed in accordance with local and national electrical codes.
- This product is designed for indoor/compartment installation. It must not be exposed to rain, snow, moisture or liquids of any type.
- Use insulated tools to reduce the chance of electrical shock or accidental short circuits.
- Remove all jewelry such as rings, watches, bracelets, etc., when installing or performing maintenance on the inverter.
- Both AC and DC overcurrent protection must be provided as part of the installation.
- Use Class 1 wiring methods for field wiring connections to terminals of a Class 2 circuit.
- Listed or labeled equipment shall be installed and used in accordance with any instructions included in the listing or labeling.
- To reduce risk of electric shock, disconnect all wiring before attempting any maintenance or cleaning. Turning off the inverter will not reduce this risk, the inverter bypass must be used or the panel should be totally disconnected from all sources.
- All wiring must have a minimum rating of 150V, 75°C when using 120V AC inverters; or 300V, 75°C when using 120/240V AC inverters.
- AC wiring must be no less than 10 AWG (5.3 mm²) gauge copper wire.
- Battery cables should be no less than #4/0 AWG unless fused close to the battery bank for smaller sized cables.
- Crimped and sealed copper ring terminal lugs with a 3/8" hole should be used to connect to the DC terminals inside the MP enclosure. Soldered cable lugs are also acceptable.
- Torque all AC wiring connections and DC cable connections to the required torque values.

READ AND SAVE THESE INSTRUCTIONS

1.3 Battery Safety

IMPORTANT BATTERY SAFETY INSTRUCTIONS

- Be very careful when working around batteries, they can produce extremely high currents if short-circuited. Read the battery supplier's precautions before installing and connecting the inverter and batteries.
- Wear eye protection such as safety glasses when working with batteries.
- Remove all jewelry such as rings, watches, bracelets, etc., when installing or performing maintenance on the batteries.
- Never work alone. Always have someone near you when working around batteries.
- Use proper lifting techniques when working with batteries.
- Never use old or untested batteries. Check each battery's label for age, type, and date code to ensure all batteries are identical.
- Batteries are sensitive to changes in temperature. Always install batteries in a stable environment.
- Install batteries in a well ventilated area. Batteries can produce explosive gasses. For compartment or enclosure installations, always vent batteries to the outside.
- Provide at least one inch of air space between batteries to provide optimum cooling.
- Never smoke when in the vicinity of batteries.
- To prevent a spark at the battery and reduce the chance of explosion, always connect the cables to the batteries first. Then connect the cables to the MP enclosure/inverter system.
- Use insulated tools at all times.
- Always verify proper polarity and voltage before connecting the batteries to the MP enclosure/inverter system.
- To reduce the chance of fire or explosion, do not allow the battery terminals to be short-circuited.
- In the event of accidental exposure to battery acid, wash thoroughly with soap and water. In the event of exposure to the eyes, flood them for at least 15 minutes with running water and seek immediate medical attention.
- Recycle old batteries.
- Be extra cautious to reduce the risk of dropping a metal tool onto batteries. It could short-circuit the batteries or other electrical parts, resulting in sparks that could cause a fire or an explosion.
- Cover the terminals to prevent accidental shorting.

READ AND SAVE THESE INSTRUCTIONS

2.0 Introduction

2.0 Introduction

The Magnum Panels (MP) are part of a new line of enclosures from Magnum Energy that standardize inverter installations and allow for the ability to expand the inverter system in the future. Specifically designed for multiple inverter applications, the MP enclosures ensure safety and reliability by combining all of the major components required for a renewable energy system — inverter/battery disconnect, AC overcurrent protection, grounding connections, and a full-system bypass switch — into an easy to install pre-wired enclosure. The modular design of the MP enclosure with the Magnum Energy inverter allows it to be UPS shipped and easily assembled on site.

Installing an inverter system is now as simple as mounting the MP enclosure, installing the inverters, connecting the battery bank, and if needed, bringing in AC power from a generator or the utility grid. Now all of the inverter's required AC and DC disconnects and wire connection points are all together, and integrated in the self-contained MP enclosure.

2.1 MP Series Overview

The MP enclosures are available in four basic configurations: the MP5L-30D, MP5H-30D, and MP5D-30D are designed to be used with the Magnum MS-PAE inverter models when stacked in parallel; and the MP5L-60S, which is designed for use with two MS4024 inverters when stacked in series. These configurations provide different maximum power abilities to meet present and future requirements.

2.1.1 Models

MP5L-30D (Magnum Panel, Single Enclosure, Low Capacity, Double-pole 30A AC input breakers)

MP5L-60S (Magnum Panel, Single Enclosure, Low Capacity, Single-pole 60A AC input breaker)

MP5H-30D (Magnum Panel, Single Enclosure, High Capacity, Double-pole 30A AC input breakers)

MP5D-30D (Magnum Panel, Dual Enclosure, High Capacity, Double-pole 30A AC input breakers)

2.1.2 Standard Features

The main components and features for the MP Series enclosures are:

- Standard configurations allow future expansion using MPX enclosures for increased power
- Enclosure is steel construction with a durable, white powder coat finish to help prevent corrosion
- Built-in, pre-wired, full system bypass switch for inverter isolation/battery maintenance
- Front-mounted AC and DC breakers for quick and easy operation
- AC, DC, and Ground busbars with set-screw type compression terminals (no lugs required)
- Full system capacity shunt (500 or 1000 DCA), allows easy connection to battery monitor
- Enclosure and components are certified for indoor use to UL/CSA standards
- DC negative and ground busbars (negative can be isolated if PV-GFP device installed)
- Battery positive busbar for DC loads and PV arrays included (not available on MP5H-30D)
- Space available to add DC load/disconnect breakers (not available on MP5H-30D)
- Standalone top plate provided to allow other (non-Magnum) inverter installations
- Knockouts for inverter and battery cables, PV in/out, DC breakers
- Data cables with 300-volt rated insulation provided to allow 240V AC inverter installations
- Easy accessibility for field installation/wiring of additional breakers/components
- Pre-wired AC over-current circuit breaker protection to the inverter's input
- Space for additional AC breakers (depends on enclosure configuration)
- Inverter DC disconnect with inverter-to-breaker battery cables included
- Plated copper busbars included for up to six additional battery positive and negative circuits

2.1.3 Individual Features

MPSL-30D (Magnum Panel, Single Enclosure, Low Capacity, Double 30A AC Inverter Input Breaker)

Capability for one MS-PAE Series inverter (expandable to a maximum of two MS-PAE Series inverters stacked in parallel using an optional MPX extension box).

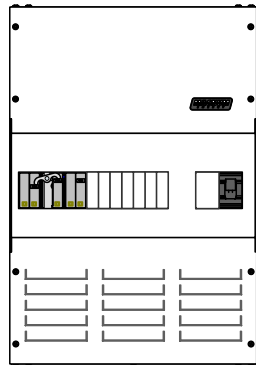

MPSL-30D (as shipped)

Includes:

- D30A AC Inverter Input Breaker (x1)
- 250A DC Disconnect (x1)
- Inverter AC Input/Output wires
- Data cables rated for 120/240V AC circuits
- D60A AC System Bypass
- 500A/50mV DC Shunt
- Inverter Hood (x1)
- Router Bracket

Figure 2-1a, MPSL-30D as Shipped

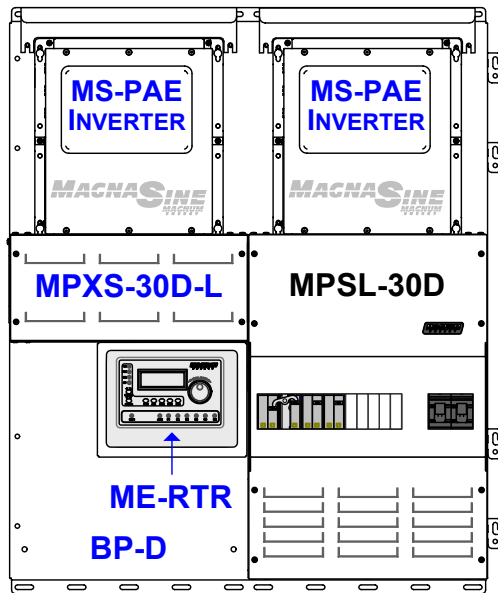

MPSL-30D

with **MPXS-30D-L** (MPX - Left Side)

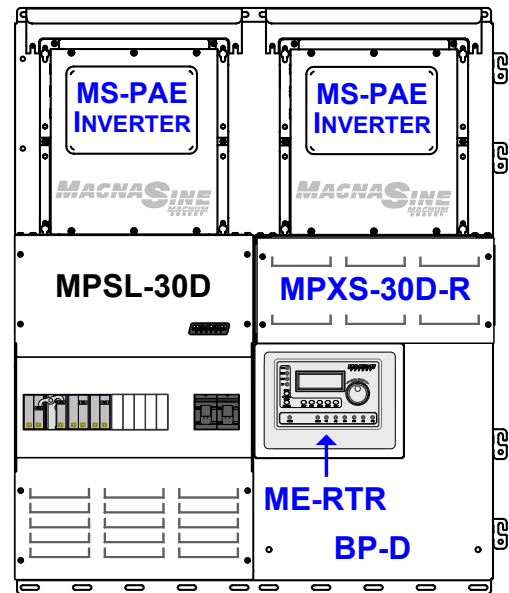

MPSL-30D

with **MPXS-30D-R** (MPX - Right Side)

Includes:

- D30A AC Inverter Input Breakers (x2)
- 250A DC Disconnects (x2)
- Inverter AC Input/Output wires
- Data cables rated for 120/240V AC circuits
- D60A AC System Bypass
- 500A/50mV DC Shunt
- Inverter Hoods (x2)
- Router Bracket

Field Installed Options Shown (not included):

- PAE Series parallel-stack inverters (x2)
- ME-RTR Router
- BP-D Dual Mounting Backplate

Figure 2-1b, MPSL-30D with Field Installed Options

2.0 Introduction

MPSL-60S (Magnum Panel, Single Enclosure, Low Capacity, Single 60A AC Inverter Input Breaker)

Capability for one MS4024 inverter (expandable to two MS4024's stacked in series using an optional MPX extension box)

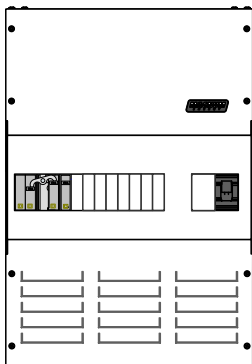

MPSL-60S (as shipped)

Includes:

- S60A AC Inverter Input Breaker (x1)
- 250A DC Disconnect (x1)
- Inverter AC Input/Output wires
- Data cables rated for 120/240V AC circuits
- D60A AC System Bypass
- 500A/50mV DC Shunt
- Inverter Hood (x1)
- Router and Charge Controller Bracket

Figure 2-2a, MPSL-60S as Shipped

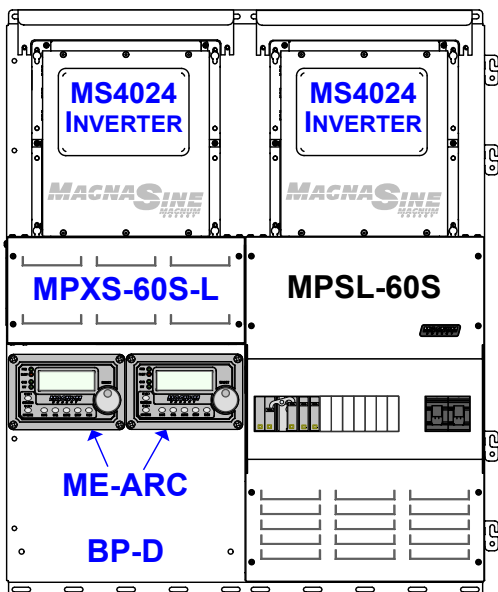

MPSL-60S

with **MPXS-60S-L** (MPX - Left Side)

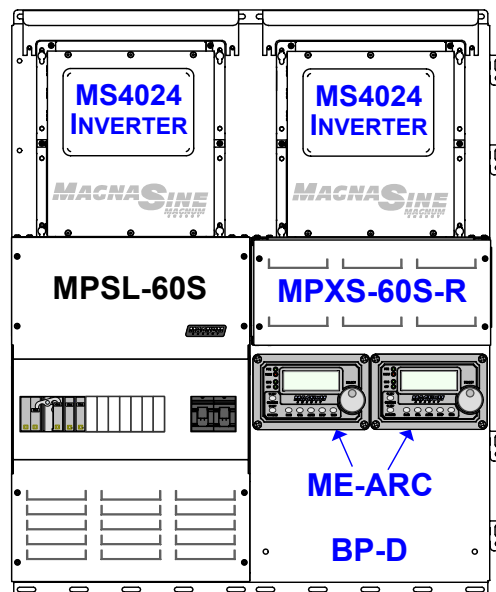

MPSL-60S

with **MPXS-60S-R** (MPX - Right Side)

Includes:

- S60A AC Inverter Input Breakers (x2)
- 250A DC Disconnects (x2)
- Inverter AC Input/Output wires
- Data cables rated for 120/240V AC circuits
- D60A AC System Bypass
- 500A/50mV DC Shunt
- Inverter Hoods (x2)
- Series Stacking Cable

Field Installed Options Shown (not included):

- MS4024 series-stack inverters (x2)
- ME-ARC Advanced Remotes (x2)
- BP-D Dual Mounting Backplate

Figure 2-2b, MPSL-60S with Field Installed Options

MPSH-30D (Magnum Panel, Single Enclosure, High Capacity, Double 30A AC Inverter Input Breaker)
 Capability for one MS-PAE Series inverter (expandable to a maximum of three MS-PAE Series inverters stacked in parallel using optional MPX extension boxes)

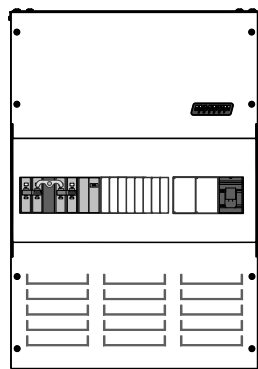

MPSH-30D (as shipped)

Includes:

- D30A AC Inverter Input Breaker (x1)
- 250A DC Disconnect (x1)
- Inverter AC Input/Output wires
- Data cables rated for 120/240V AC circuits
- D125A AC System Bypass
- 1000A/100mV DC Shunt
- Inverter Hood (x1)
- Router and Charge Controller Bracket

Figure 2-3a, MPSH-30D as Shipped

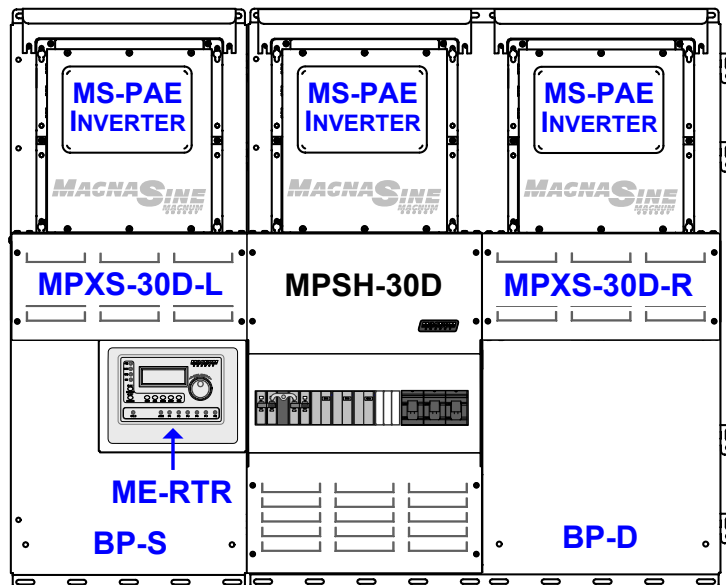

MPSH-30D with **MPXS-30D-L** (MPX - Left Side) and **MPXS-30D-R** (MPX - Right Side)

Includes:

- D30A AC Inverter Input Breakers (x3)
- 250A DC Disconnects (x3)
- Inverter AC Input/Output wires
- Data cables rated for 120/240V AC circuits
- D125A AC System Bypass
- 1000A/100mV DC Shunt
- Inverter Hoods (x3)
- Router and Controller Bracket

Field Installed Options Shown (not included):

- PAE Series parallel-stack inverters (x3)
- ME-RTR Router
- BP-S Single Mounting Backplate
- BP-D Dual Mounting Backplate

Figure 2-3b, MPSH-30D with Field Installed Options

2.0 Introduction

MPDH-30D (Magnum Panel, Dual Enclosure, High Capacity, Double 30A AC Inverter Input Breakers)

Capability for one or two MS-PAE Series inverters (expandable to a maximum of four MS-PAE Series inverters stacked in parallel using optional MPX extensions).

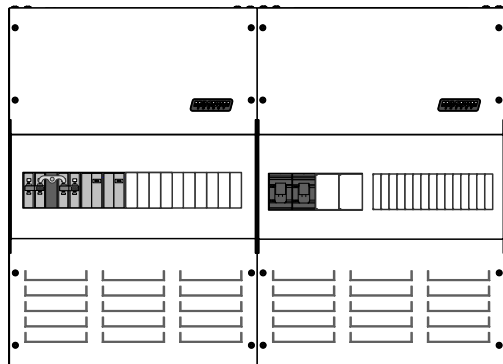

MPDH-30D (as shipped)

Includes:

- D30A AC Inverter Input Breakers (x2)
- 250A DC Disconnects (x2)
- Inverter AC Input/Output wires
- Data cables rated for 120/240V AC circuits
- D125A AC System Bypass
- 1000A/100mV DC Shunt
- Inverter Hoods (x2)
- Router and Charge Controller Bracket

Figure 2-4a, MPDH-30D as Shipped

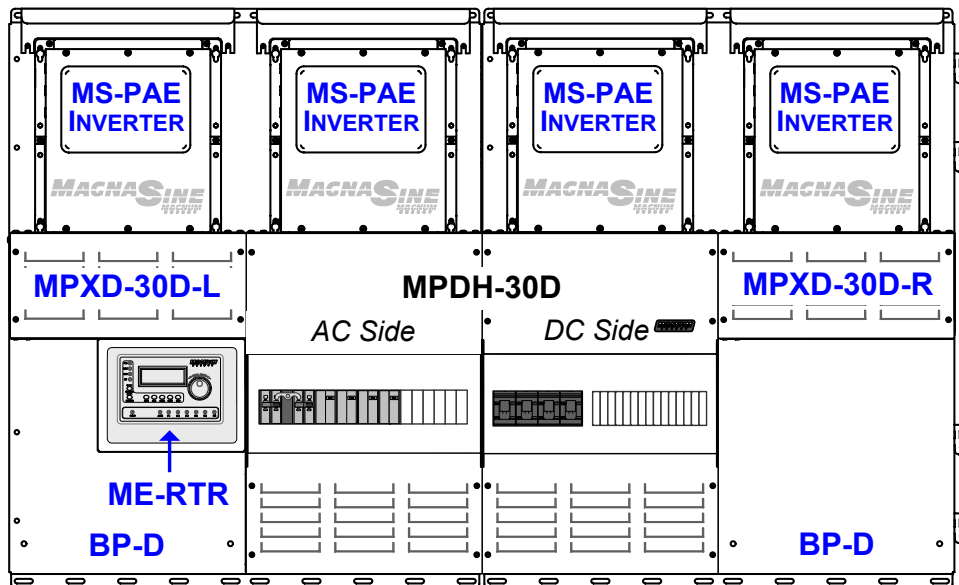

MPDH-30D with MPXD-30D-L (MPX - Left Side) and MPXD-30D-R (MPX - Right Side)

Includes:

- D30A AC Inverter Input Breakers (x4)
- 250A DC Disconnects (x4)
- Inverter AC Input/Output wires
- Data cables rated for 120/240V AC circuits
- D125A AC System Bypass
- 1000A/100mV DC Shunt
- Inverter Hoods (x4)
- Router and Controller Bracket

Field Installed Options Shown (not included):

- PAE Series parallel-stack inverters (x4)
- ME-RTR Router
- BP-D Dual Mounting Backplates (x2)

Figure 2-4b, MPDH-30D with Field Installed Options

2.1.4 Physical Features

- MP Dimensions (H x W x D): Each Enclosure = 18" x 13" x 6.75" (45.7cm x 33cm x 17.1cm)
- MP Weight: MPSL = 48 lbs. (21.8 kg), MPSH = 51 lbs. (23.1 kg), MPDH (AC Side) = 44 lbs. (20 kg), MPDH (D Side) = 46 lbs. (20.7 kg)
- Shipping Dimensions (H x W x D): 26.75" x 17.75" x 14.75" (56.9cm x 38.1cm x 31.8cm)
- Shipping Weight: MPSL = 50 lbs. (22.7 kg), MPSH = 53 lbs. (24 kg), MPDH (AC Side) = 46 lbs. (20.7 kg), MPDH (D Side) = 48 lbs. (21.8 kg)

2.1.5 Optional Accessories/Components

- **ME-RC** – Remote Control with LCD display; allows inverter (or connected accessory) to be configured and monitored, and maintains the critical settings in nonvolatile memory.
- **ME-ARC** – Advanced Remote Control with LCD display; has all the features of the ME-RC remote, but also configures the advanced features of the inverter (or any connected accessory).
- **ME-RTR** – The ME-RTR, or "router" provides parallel capability for the MS-PAE Series inverters and includes many of the same features as the ME-ARC advanced remote control. The router is designed with a user-friendly LCD display and rotary SELECT knob that allows all connected MS-PAE series inverter/chargers to be programmed in sync without the need to program each inverter separately. The router will accommodate up to four MS-PAE inverter/chargers in parallel, plus accessories.
- **ME-BMK-NS** – Battery Monitor; determines battery State of Charge (DC shunt not included).
- **ME-AGS-N** – Automatic Generator Start Controller (Network version); automatically starts/stops generators.
- **BP-S** – Single Mounting Backplate; for mounting a Magnum inverter and MP/MPX enclosures. It can be combined with the BP-D for additional mounting surface area. UPS shippable.
- **BP-D** – Dual Mounting Backplate; for mounting a Magnum inverter and MP/MPX enclosures, It can be combined with the BP-S for additional mounting surface area. UPS shippable.
- **DC Breakers** – MP enclosure has space for E-Frame/back-mounted (1" width) or Q-Frame/DIN rail-mounted (1/2" width) DC breakers (not applicable for the MPSH-30D model).
- **MPX Extensions** – These enclosures allow additional Magnum inverters to be mounted and electrically wired to the Magnum Panel to allow an integrated panel system. The top of the MPX is designed to allow Magnum inverters to fit seamlessly into the top. The MPX Series enclosures come with the AC and DC breakers and wiring to install another Magnum inverter. An inverter hood is also included with each MPX extension to allow the inverter to be mounted vertically.
- **ME-MW-W** - The MagWeb Wireless allows Magnum Energy's inverters and accessories to be remotely monitored. Installed on the Magnum network, the MagWeb provides live Internet monitoring of the inverter, battery monitor, and automatic generator start module. Using your always on Internet connection, the MagWeb makes live and historical conditions available to you through a web browser at <http://data.magnumenergy.com>.

2.2 Regulatory Compliance

The MP enclosure carries the ETL Listed Mark and is designated as **Interconnection System Equipment** (ISE) for use with inverters. It has been independently tested and certified by Intertek Testing Services (known as ETL) to UL 1741, 2nd Edition, and is also CSA certified to C22.2 No. 107.1-01 (R2006). These certifications mean the MP enclosure meets the minimum requirements of prescribed product safety standards.

Note: ETL is a Nationally Recognized Testing Laboratory (NRTL). NRTL's are qualified organizations that meet the requirements of Occupational Safety and Health Administration (OSHA) regulations to perform independent safety testing and product certification.

2.0 Introduction

2.3 MP External Components

The main external components of the MPSL and MPSH enclosures (as shown in Figure 2-5) and the MPDH enclosure (as shown in Figure 2-6) are described below:



Info: The external components are secured to the enclosure using #10-32 x 3/8" (Pan head, T25 Torx drive) thread cutting screws and #10 lock washers.



Inverter Plate - The MP enclosure is factory shipped with the inverter plate installed. This plate allows a Magnum inverter to sit on top of the MP enclosure, and allow the AC and DC wiring to be easily routed from the inverter to the MP enclosure.

The inverter plate can be replaced with the **Knockout Plate**, which is used as an upper conduit/safety plate. See Section A5 for more information on the Knockout Plate.



WARNING: To prevent accidental access to live electrical circuits inside the MP enclosure, the Knockout Plate must be installed if the Magnum inverter is removed for service and the AC bypass breaker is switched ON.

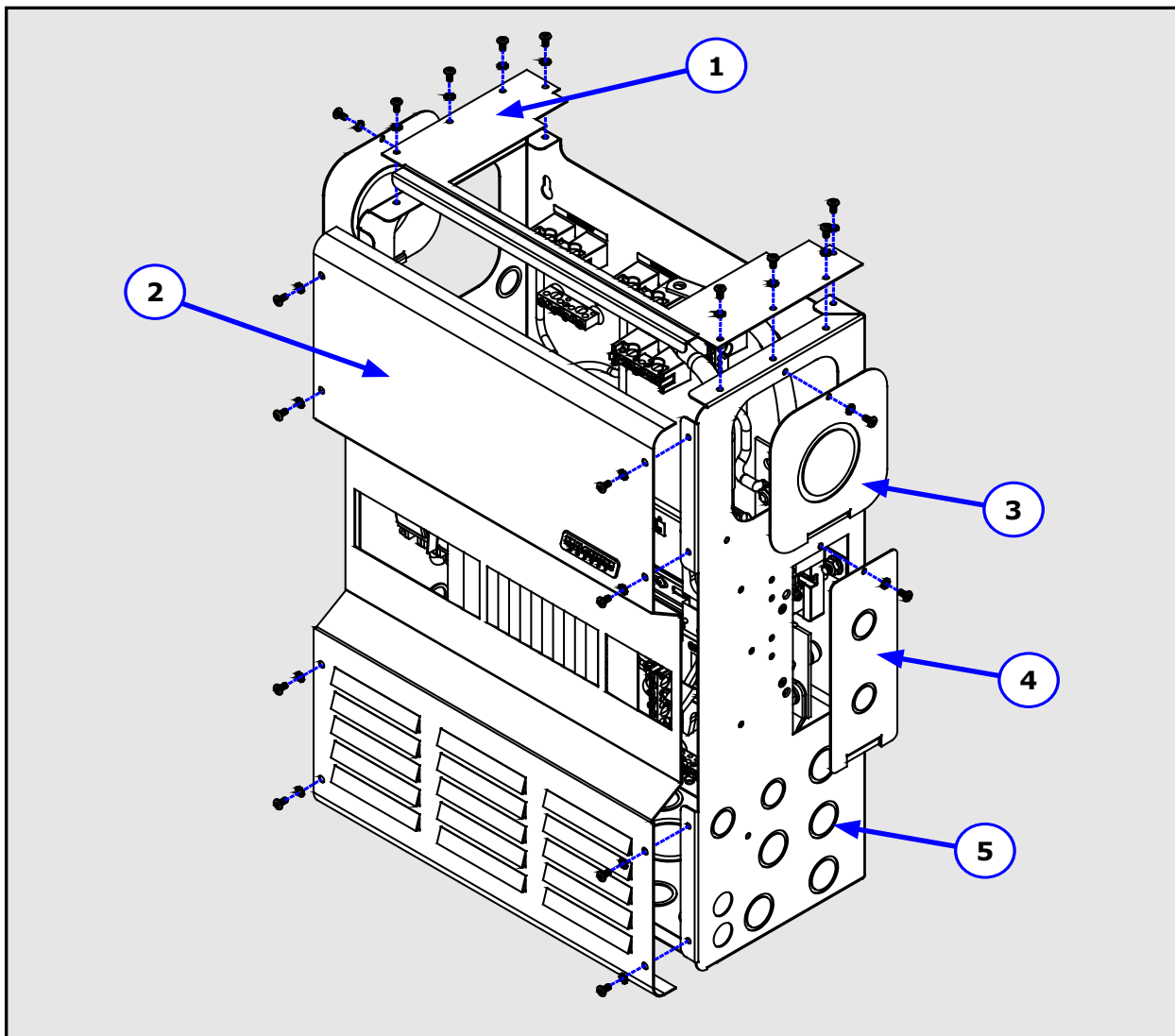

Figure 2-5, MPSL and MPSH External Components

- 2 **Front Panel Cover** - The cover(s) on the front of the MP enclosures can be removed to access the internal components. The front cover panels are equipped with rectangular knockouts, to allow additional AC and DC circuit breakers to be installed.
- 3 **MP Side Access Plate (x2)** - These access plates (one on each side) allow the power and communications conductors to be routed from the main MP enclosure to a MPX extension box (when used).
- 4 **DC Shunt Access Plate** - This plate allows access to the DC shunt (for connecting a battery monitor) and the DC ground stud.
- 5 **Conduit Knockouts** - Multiple sized knockouts on the side and bottom of the MP enclosure are provided to allow metal and PVC conduits. For dimensions and sizes, see Figures 3-13 and 3-14.

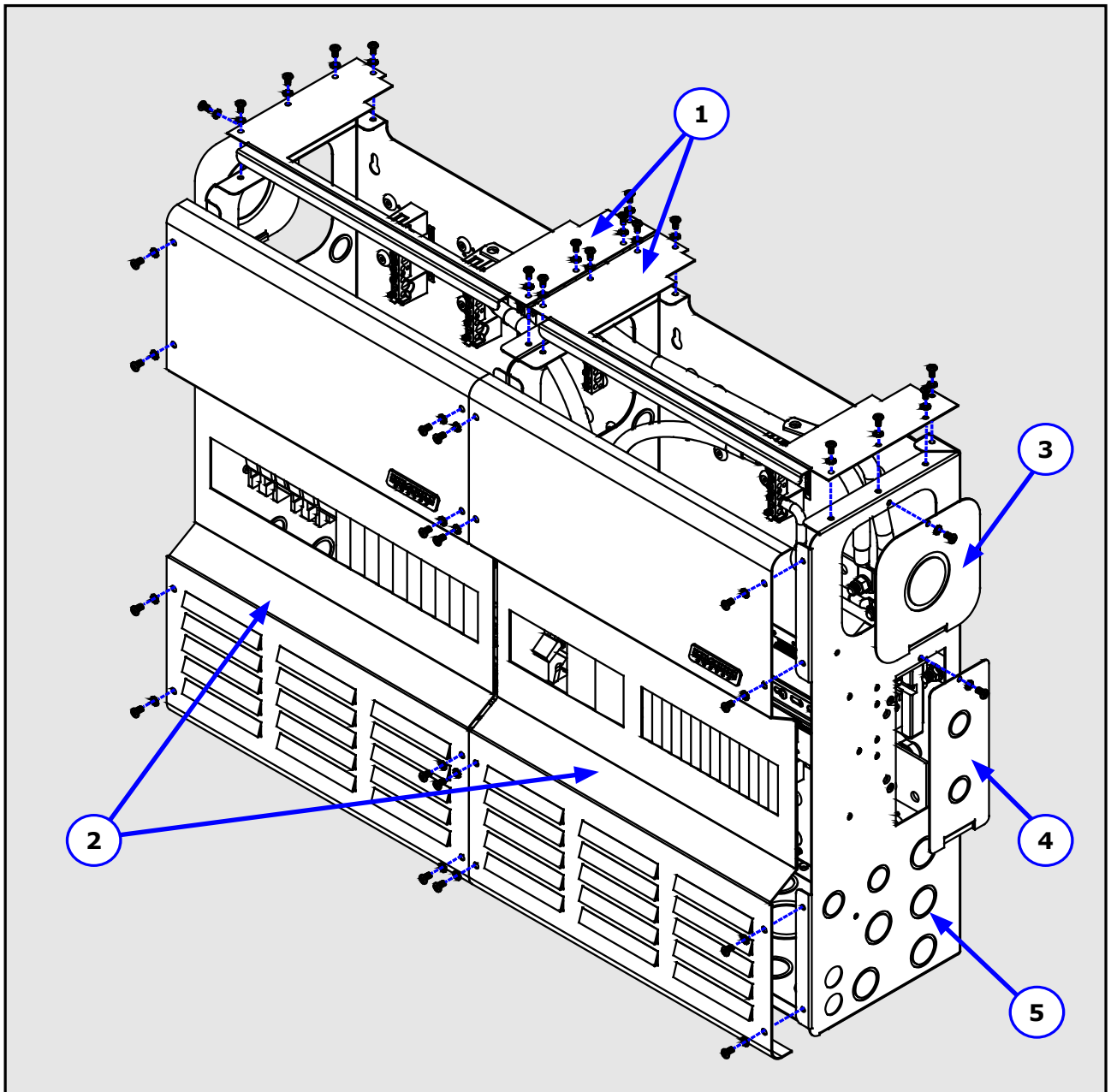

Figure 2-6, MPDH External Components

2.0 Introduction

2.4 MP Internal Components

Additional components are located inside the MP enclosure. The components found inside the MPSL-30D (see Figure 2-7), the MPSL-60S (see Figure 2-8), the MPSH-30D (see Figure 2-9), and the MPDH-30D (see Figures 2-10a and 2-10b) are listed alphabetically and described below:



Info: All the busbars have dual hole sizes — the larger holes accept #14 to #1/0 AWG and the smaller holes accept #14 to #6 AWG — these holes have set-screw type compression terminals (no ring lugs required). The number of terminals available depends on the particular busbar and the MP model.



Info: All AC Ground Busbars, DC Ground Busbars, and the DC Ground Stud are electrically common to each other as they are all connected to the MP chassis.

AC GROUND Busbar(s) - These busbars are connected to the MP enclosure chassis and are used to connect the incoming and outgoing AC circuit grounds to a common ground point.

AC LEG 1 IN Busbar - Connects incoming LEG 1 AC power from the grid or a generator to the MP/inverter system. This busbar is used to connect the LEG 1 output of a 120/240V AC external source (grid power or AC generator) to the MP enclosure. The AC LEG 1 IN busbar is connected to the HOT 1 input of the inverter system (thru the inverter's AC input breaker). The external source is used by the inverter to charge the batteries and power downstream loads thru the inverter.

AC LEG 1 OUT Busbar - Supplies the LEG 1 power from the MP/inverter system to the AC loads. This busbar is the connection point from the MP enclosure to the LEG 1 terminal in the electrical panel powered by the inverter.

AC LEG 2 IN Busbar - Connects incoming LEG 2 AC power from the grid or a generator to the MP/inverter system. This busbar is used to connect the LEG 2 output of a 120/240V AC external source (AC generator or grid power) to the MP enclosure. The AC LEG 2 IN busbar is connected to the HOT 2 input of the inverter system (thru the inverter's AC input breaker). This external source is used by the inverter to charge the batteries and power downstream loads thru the inverter.

AC LEG 2 OUT Busbar - Supplies the LEG 2 power from the MP/inverter system to the AC loads. This busbar is the connection point from the MP enclosure to the LEG 2 terminal in the electrical panel powered by the inverter.

AC NEUTRAL Busbars - The neutral leg for loads powered from the MP/inverter system and the neutral leg for AC power supplied to the MP/inverter system by either a generator or grid. These two busbars are the connection points for the AC neutrals in the system. The system neutrals include: the neutral output from the external AC source (generator/grid), the neutral terminal in the electrical panel that is powered by the inverter, and the input and output neutral terminals of each inverter. **Note:** Both AC NEUTRAL busbars are electrically connected to each other.

- Installing MS-PAE Series inverters: Both neutral terminals are common with each other within the MS-PAE Series, this means only one neutral from each MS-PAE inverter needs to connect to the AC NEUTRAL busbar.
- Installing MS4024 inverters: The Neutral In and Neutral Out are not common with each other within the MS4024; this means both input and output neutrals from each MS4024 inverter needs to connect to the AC NEUTRAL busbar.

AC NEUTRAL-GROUND Connection - A wire (green) connects the AC neutral to the system ground. This green wire can be removed from the GROUND busbar if the primary AC neutral to ground connection is made elsewhere in the system (see Section 3.10).

Battery Negative Connection - The bottom of the DC Shunt busbar is the connection point to the negative terminal of the battery bank. This busbar is supplied with a 3/8-16 bolt and lock washer to allow the battery cable to be connected.

Battery Positive Connection - The bottom of the inverter's DC disconnect is the connection point to the positive terminal of the battery bank. The DC disconnect provides a rear captive nut to allow the battery cable to be front-connected using a 3/8-16 bolt and lock washer.

DC GROUND Busbar - This busbar is connected to the MP enclosure chassis and is used to tie DC equipment grounds to a common point. This terminal is also used to connect the inverter/MP/inverter system to the DC grounding electrode. If the DC grounding electrode conductor is greater than #1/0 AWG, use the DC Ground Stud to connect to the DC grounding electrode (i.e., ground rod).

DC Ground Stud - This 5/16-18 stud is connected to the MP enclosure chassis, and is provided as a connection point to the DC grounding electrode when the conductor is larger than #1/0 AWG. This stud also connects to the DC shunt through a busbar and serves as the DC negative to ground connection point. If installing a PV-GFP device, this busbar must be removed (see Section 3.11). **Note:** For ground wires #1/0 AWG or smaller, use the DC GROUND busbar.

DC NEGATIVE Busbar - This busbar is connected to the battery bank negative through the load side of the DC shunt. This busbar is the battery negative connection point for additional DC circuits, such as from the DC negative output of a charge controller or when combining the negatives of DC load circuit breakers. This busbar is rated to handle 120 amps.

DC NEGATIVE-GROUND Connection - This busbar connects the DC negative to the system ground. It must be removed if the primary DC negative to ground connection is made elsewhere in the system (see Section 3.11).

DC POSITIVE Busbar - This busbar is connected to the battery bank positive through the bottom of the inverter DC disconnect. This busbar is the battery positive common point for connecting additional DC circuits, such as from the output of a charge controller disconnect, the DC positive feed to DC load breakers, and the positive connection to a battery status monitor. This busbar is rated to handle 120 amps.

DC Shunt - A DC shunt installed in the DC negative side that is used to measure the amperage flowing between the battery and the inverter (and any DC loads connected). This shunt is pre-installed so that a battery monitor may be easily connected to display the current flow. See Section A-2 for information on installing and wiring the ME-BMK-NS battery monitor inside the MP enclosure. The MPLS-30D and MPLS-60S are supplied with a 500 amp/50mV DC shunt, and the MPLS-30D and MPDH-30D have a 1000A/100mV DC shunt.

DC Shunt Voltage Sense Terminals - These two shunt terminals/screws serve as the sense connections to the optional ME-BMK-NS battery monitor. When current is passed through the shunt, the IR drop (AKA voltage drop) developed across it can be read by the battery monitor to provide an accurate indication of the current flowing through the shunt.

DIN Rail Track - For installing up to 1/2" (12.7mm) wide, DIN rail-mounted, Q-Frame type, DC breakers. These breakers can be used for connecting DC loads or installing a PV-GFP device. The track may be removed to allow 1" (25.4mm) wide, back-mounted, E-Frame type breakers to be installed instead.

Enclosure Joining Screw/Washer - A #10-32 x 3/8" (Pan head, T25 Torx drive) thread cutting screw and #10 lock washers are provided to join the two enclosures of the MPDH-30D together - to have them at the same electrical potential. See Figure 3-16c for more information.

INV HOT 1 OUT Busbar - This busbar is the connection point for the HOT 1 output from each installed inverter. The total output power combined from every inverter on this busbar is fed thru the **Inverter Bypass Breaker Assembly** to the **AC LEG 1 OUT Busbar**.

INV HOT 2 OUT Busbar - This busbar is the connection point for the HOT 2 output from each installed inverter. The total output power combined from every inverter on this busbar is fed thru the **Inverter Bypass Breaker Assembly** to the **AC LEG 2 OUT Busbar**.

2.0 Introduction

Inverter AC Input Breakers - These breakers provide protection to the inverter's AC input circuit, a way to disconnect the AC input to the inverters, and overcurrent protection to the inverter's input wires when the minimum recommended AC wire sizes are used. Depending on your MP model, the breaker provided for the inverter input will be either a double-pole 30 amp (D30A) or a single-pole 60 amp (S60A) AC breaker.

The double-pole 30 amp AC breaker is provided on the MPSL-30D, MPSH-30D, and MPDH-30D models to allow 120/240V AC inverters — up to 30 AC amps per leg pass-thru capability — to be connected. The MPSL-30D and MPSH-30D come with one double-pole 30A input breaker and the MPDH-30D comes with two double-pole 30A breakers. These three models require a double-pole 30A breaker for each additional inverter installed in a parallel-stacked configuration.

The single 60 amp AC breaker is provided on the MPSL-60S models to allow 120V AC inverters — up to 60 AC amps pass-thru capability — to be connected. If connecting MS4024's in a series-stacked configuration, an additional single pole 60A breaker for the second MS4024 will be required (as provided in the MPX extension kit).

Inverter Bypass Breaker Assembly - The Inverter AC Bypass Breaker Assembly is pre-wired at the factory and consists of the inverter bypass switch and the inverter AC output disconnect breaker. This breaker assembly provides a way to disconnect the AC output of the inverter system, and to directly connect the AC input to the AC output by bypassing the inverter system.

The MPSL-30D and MPSL-60S are installed with a double-pole 60-amp AC bypass breaker assembly, and the MPSL-30D and MPDH-30D are equipped with a double-pole 125-amp AC bypass breaker assembly.

Inverter DC Disconnect Breaker - This 250 amp DC disconnect is a high interruption capacity, magnetic-hydraulic, DC circuit breaker. These breakers were specifically designed and tested to work with Magnum inverters to provide the delay time needed to minimize nuisance breaker tripping. It provides an easy and convenient way to isolate the inverter from the battery, and meets the NEC/CEC requirements for DC overcurrent protection when the size and length of the battery-to-inverter cables are installed in accordance with the installation instructions in this manual. These breakers have front-accessible connections, each provided with 3/8-16 Hex head bolts with lock washers.

Inverter's DC Negative Connection - Connects to Magnum inverter's DC negative terminal.

Inverter's DC Positive Connection - Connects to Magnum inverter's DC positive terminal.

Mounting Dimples, BMK (x2) - These dimples allow the optional ME-BMK-NS (Battery Monitor Kit without DC shunt) to be installed. Two #8-32 x 1/2" (T20 Torx drive) thread cutting screws are provided to mount the battery monitor. See Section A2 for more information on mounting the battery monitor.

Mounting Holes, Inv AC Input Breakers - Used to install additional **Inverter AC Input Breakers**, which provide protection to each inverter's AC input circuit.

Mounting Holes, Inv DC Backmount Breakers - For installing 1" (25.4mm) wide, back-mounted, E-Frame type, DC breakers. These breakers can be used for connecting DC loads or installing a PV-GFP device.

Mounting Holes, Inv DC Disconnect Breakers - Used to install additional **Inverter DC Disconnect Breakers**, which isolate the inverter from the battery. These breakers meet the NEC/CEC requirements for DC overcurrent protection when used in accordance with the installation instructions in this manual.

Mounting Keyholes, MP Enclosure (x4) - Four keyholes for mounting the enclosure. See Figures 3-5 or 3-6 for size information on these keyholes.

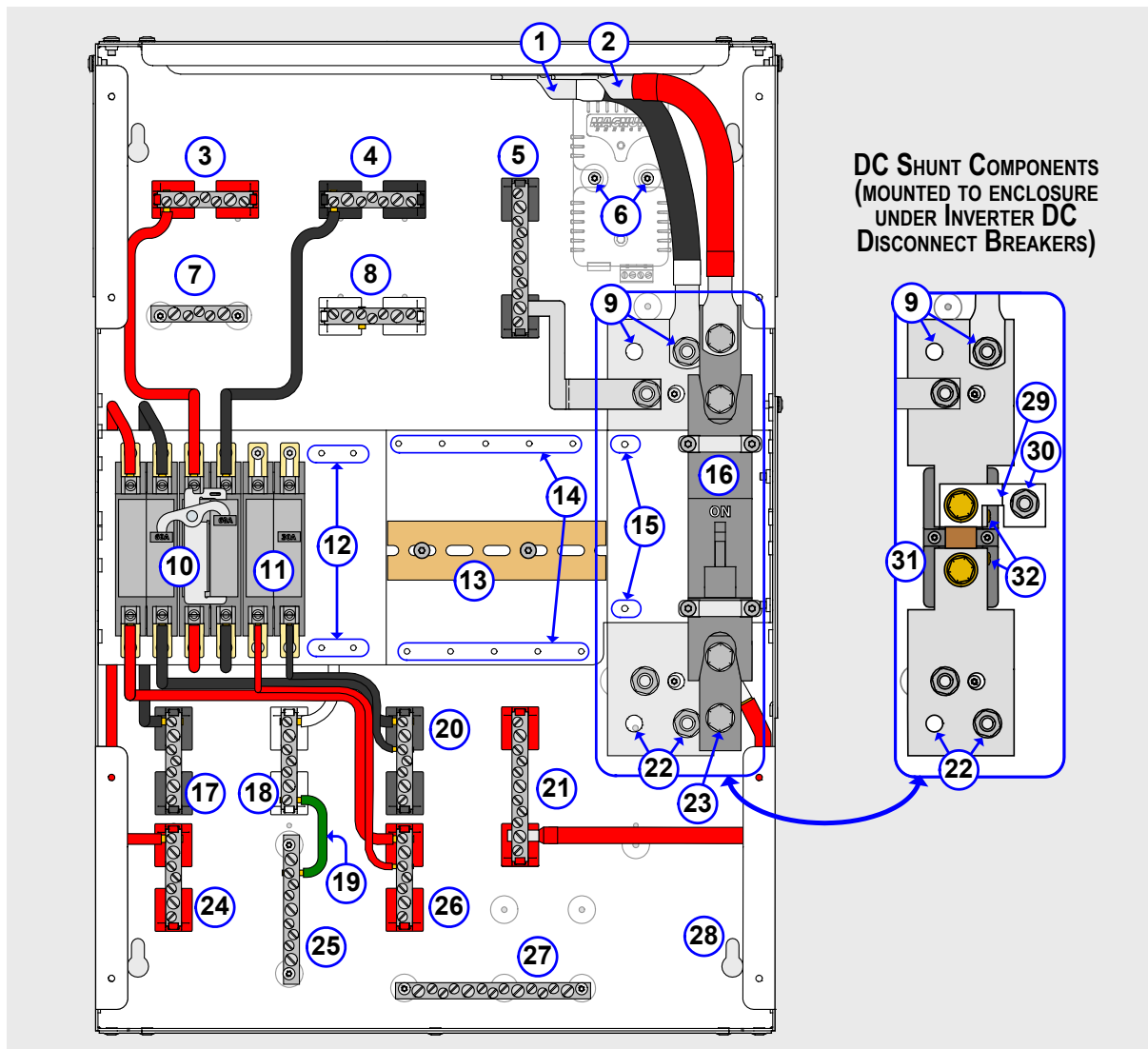

- | | | | |
|--|--|--|---|
| 1 INVERTER'S DC NEGATIVE CONNECTION (CABLE) | 2 INVERTER'S DC POSITIVE CONNECTION (CABLE) | 3 INV HOT 2 OUT BUSBAR (FROM INVERTER OUTPUT) | 4 INV HOT 1 OUT BUSBAR (FROM INVERTER OUTPUT) |
| 5 DC NEGATIVE BUSBAR | 6 MOUNTING DIMPLES, BMK (FOR ME-BMK-NS) | 7 AC GROUND BUSBAR (INVERTER INPUT/OUTPUT) | 8 AC NEUTRAL BUSBAR (INVERTER INPUT/OUTPUT) |
| 9 INVERTER DC NEGATIVE CONNECTIONS (BUSBAR) | 10 INVERTER BYPASS BREAKER ASSEMBLY (60A) | 11 INVERTER AC INPUT BREAKER (D30A) | 12 MOUNTING HOLES, TO ADD INV AC INPUT BREAKER |
| 13 DIN RAIL TRACK | 14 MOUNTING HOLES, DC BACKMOUNT BREAKERS | 15 MOUNTING HOLES, INV DC DISCONNECT BREAKER | 16 INVERTER DC DISCONNECT BREAKER |
| 17 AC LEG 1 OUT BUSBAR (TO AC LOAD PANEL) | 18 AC NEUTRAL BUSBAR (SOURCE/LOAD IN/OUT) | 19 AC NEUTRAL-GROUND CONNECTION | 20 AC LEG 1 IN BUSBAR (FROM GEN OR GRID) |
| 21 DC POSITIVE BUSBAR | 22 BATTERY NEGATIVE CONNECTIONS | 23 BATTERY POSITIVE CONNECTION | 24 AC LEG 2 OUT BUSBAR (TO AC LOAD PANEL) |
| 25 AC GROUND BUSBAR (SOURCE/LOAD IN/OUT) | 26 AC LEG 2 IN BUSBAR (FROM GEN OR GRID) | 27 DC GROUND BUSBAR | 28 MOUNTING KEYHOLES, MP ENCLOSURE (x4) |
| 29 DC NEGATIVE-GROUND CONNECTION | 30 DC GROUND STUD | 31 DC SHUNT (500A/50mV) | 32 DC SHUNT VOLTAGE SENSE TERMINALS/SCREWS |

Figure 2-7, MPSL-30D Internal Components

2.0 Introduction

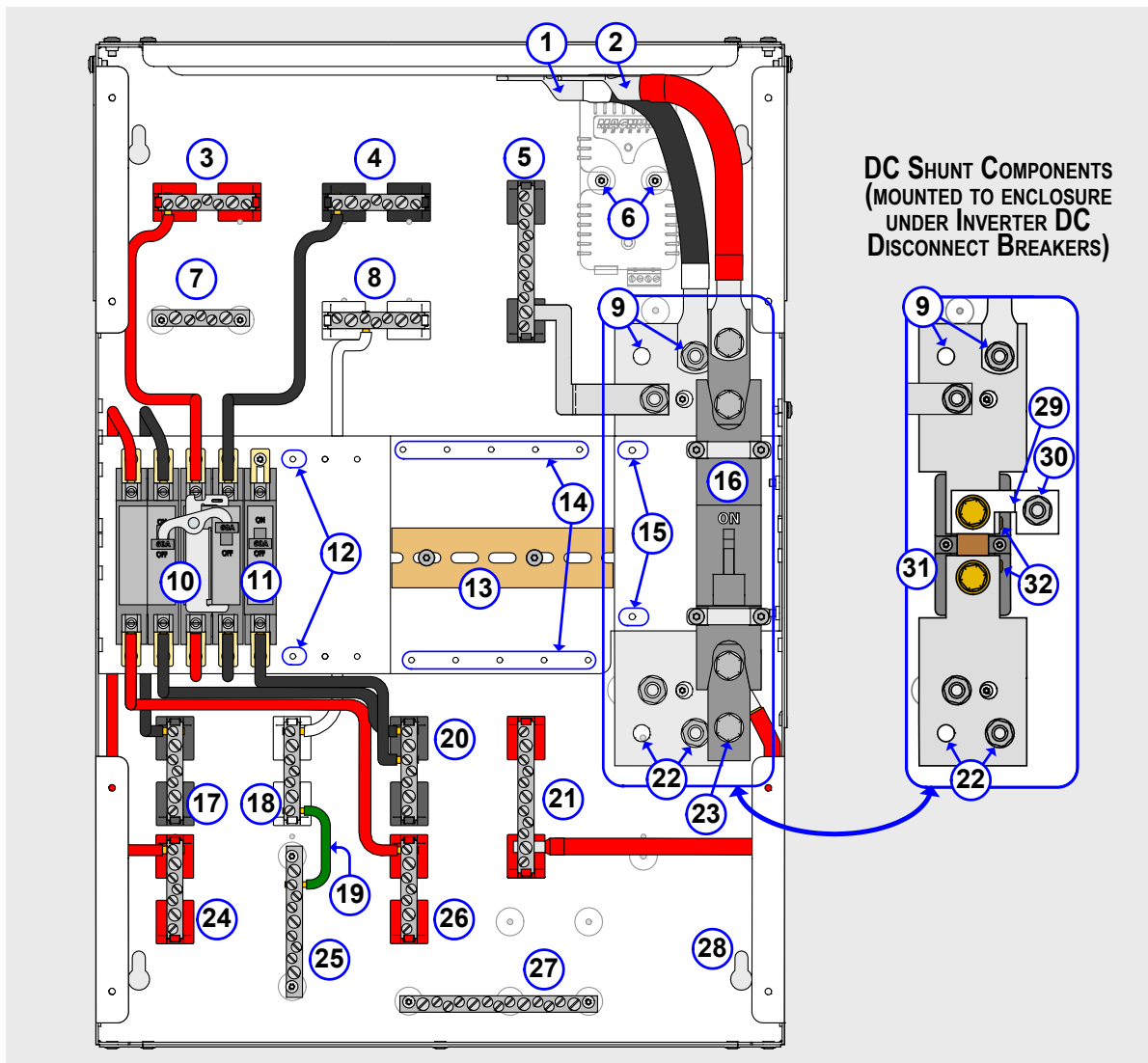

- | | | | |
|--|--|--|---|
| 1 INVERTER'S DC NEGATIVE CONNECTION (CABLE) | 2 INVERTER'S DC POSITIVE CONNECTION (CABLE) | 3 INV HOT 2 OUT BUSBAR (FROM INVERTER OUTPUT) | 4 INV HOT 1 OUT BUSBAR (FROM INVERTER OUTPUT) |
| 5 DC NEGATIVE BUSBAR | 6 MOUNTING DIMPLES, BMK (FOR ME-BMK-NS) | 7 AC GROUND BUSBAR (INVERTER INPUT/OUTPUT) | 8 AC NEUTRAL BUSBAR (INVERTER INPUT/OUTPUT) |
| 9 INVERTER DC NEGATIVE CONNECTIONS (BUSBAR) | 10 INVERTER BYPASS BREAKER ASSEMBLY (60A) | 11 INVERTER AC INPUT BREAKER (SINGLE 60A) | 12 MOUNTING HOLES, TO ADD INV AC INPUT BREAKER |
| 13 DIN RAIL TRACK | 14 MOUNTING HOLES, DC BACKMOUNT BREAKERS | 15 MOUNTING HOLES, INV DC DISCONNECT BREAKER | 16 INVERTER DC DISCONNECT BREAKER |
| 17 AC LEG 1 OUT BUSBAR (TO AC LOAD PANEL) | 18 AC NEUTRAL BUSBAR (SOURCE/LOAD IN/OUT) | 19 AC NEUTRAL-GROUND CONNECTION | 20 AC LEG 1 IN BUSBAR (FROM GEN OR GRID) |
| 21 DC POSITIVE BUSBAR | 22 BATTERY NEGATIVE CONNECTIONS | 23 BATTERY POSITIVE CONNECTION | 24 AC LEG 2 OUT BUSBAR (TO AC LOAD PANEL) |
| 25 AC GROUND BUSBAR (SOURCE/LOAD IN/OUT) | 26 AC LEG 2 IN BUSBAR (FROM GEN OR GRID) | 27 DC GROUND BUSBAR | 28 MOUNTING KEYHOLES, MP ENCLOSURE (x4) |
| 29 DC NEGATIVE-GROUND CONNECTION | 30 DC GROUND STUD | 31 DC SHUNT (500A/50mV) | 32 DC SHUNT VOLTAGE SENSE TERMINALS/SCREWS |

Figure 2-8, MPSL-60S Internal Components

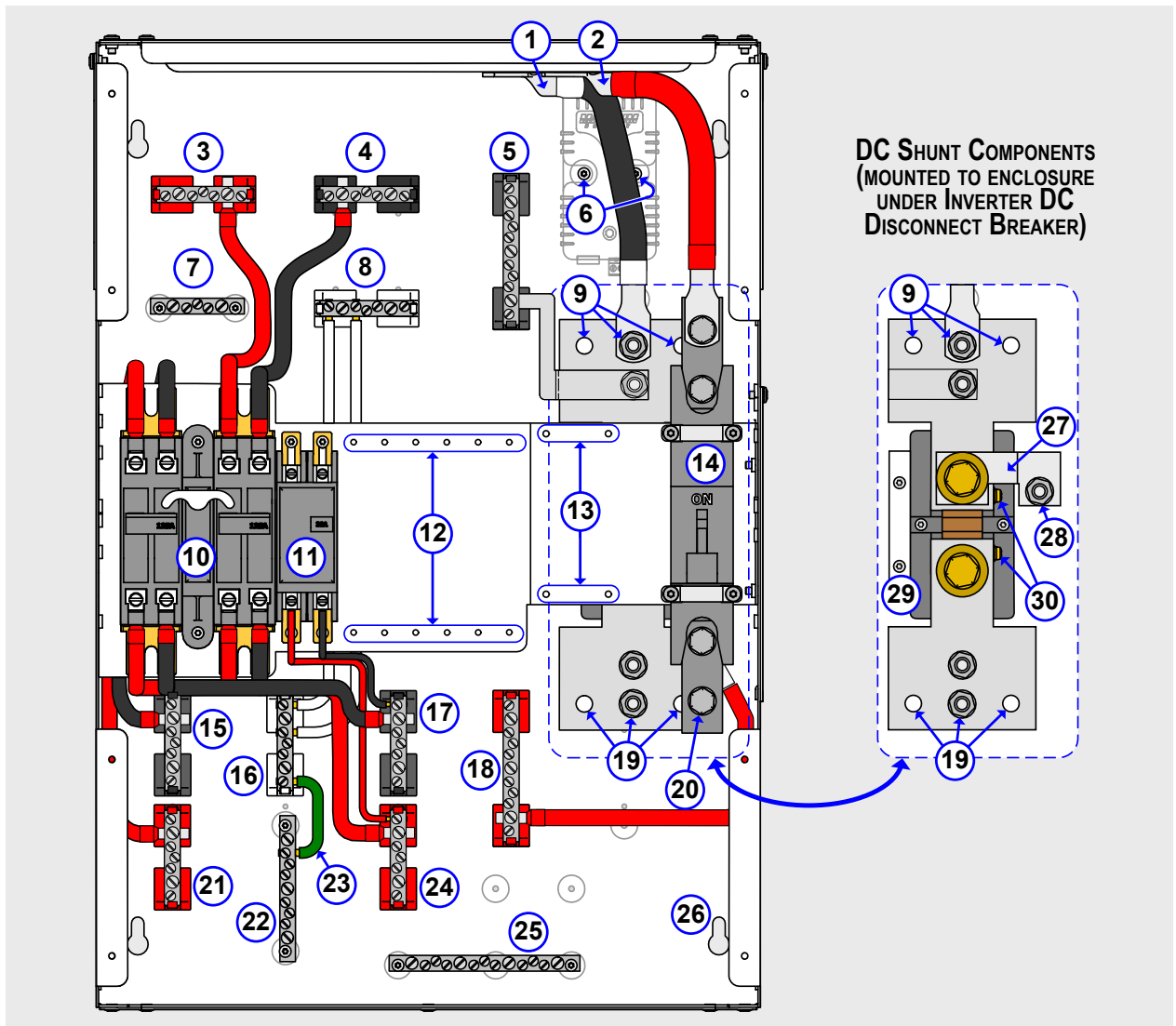

- | | | | |
|---|--|--|---|
| 1 INVERTER'S DC NEGATIVE CONNECTION (CABLE) | 2 INVERTER'S DC POSITIVE CONNECTION (CABLE) | 3 INV HOT 2 OUT BUSBAR (FROM INVERTER OUTPUT) | 4 INV HOT 1 OUT BUSBAR (FROM INVERTER OUTPUT) |
| 5 DC NEGATIVE BUSBAR | 6 MOUNTING DIMPLES, BMK (FOR ME-BMK-NS) | 7 AC GROUND BUSBAR (INVERTER INPUT/OUTPUT) | 8 AC NEUTRAL BUSBAR (INVERTER INPUT/OUTPUT) |
| 9 INVERTER DC NEGATIVE CONNECTIONS (BUSBAR) | 10 INVERTER BYPASS BREAKER ASSEMBLY (125A) | 11 INVERTER AC INPUT BREAKER (D30A) | 12 MOUNTING HOLES, TO ADD INV AC INPUT BREAKER |
| 13 MOUNTING HOLES, INV DC DISCONNECT BREAKER | 14 INVERTER DC DISCONNECT BREAKER | 15 AC LEG 1 OUT BUSBAR (TO AC LOAD PANEL) | 16 AC NEUTRAL BUSBAR SOURCE/LOAD IN/OUT |
| 17 AC LEG 1 IN BUSBAR (FROM GEN OR GRID) | 18 DC POSITIVE BUSBAR | 19 BATTERY NEGATIVE CONNECTIONS | 20 BATTERY POSITIVE CONNECTION |
| 21 AC LEG 2 OUT BUSBAR (TO AC LOAD PANEL) | 22 AC GROUND BUSBAR (SOURCE/LOAD IN/OUT) | 23 AC NEUTRAL-GROUND CONNECTION | 24 AC LEG 2 IN BUSBAR (FROM GEN OR GRID) |
| 25 DC GROUND BUSBAR | 26 MOUNTING KEYHOLES, MP ENCLOSURE (x4) | 27 DC NEGATIVE-GROUND CONNECTION | 28 DC GROUND STUD |
| 29 DC SHUNT (1000A/100mV) | 30 DC SHUNT VOLTAGE SENSE TERMINALS/SCREWS | | |

Figure 2-9, MPSH-30D Internal Components

2.0 Introduction

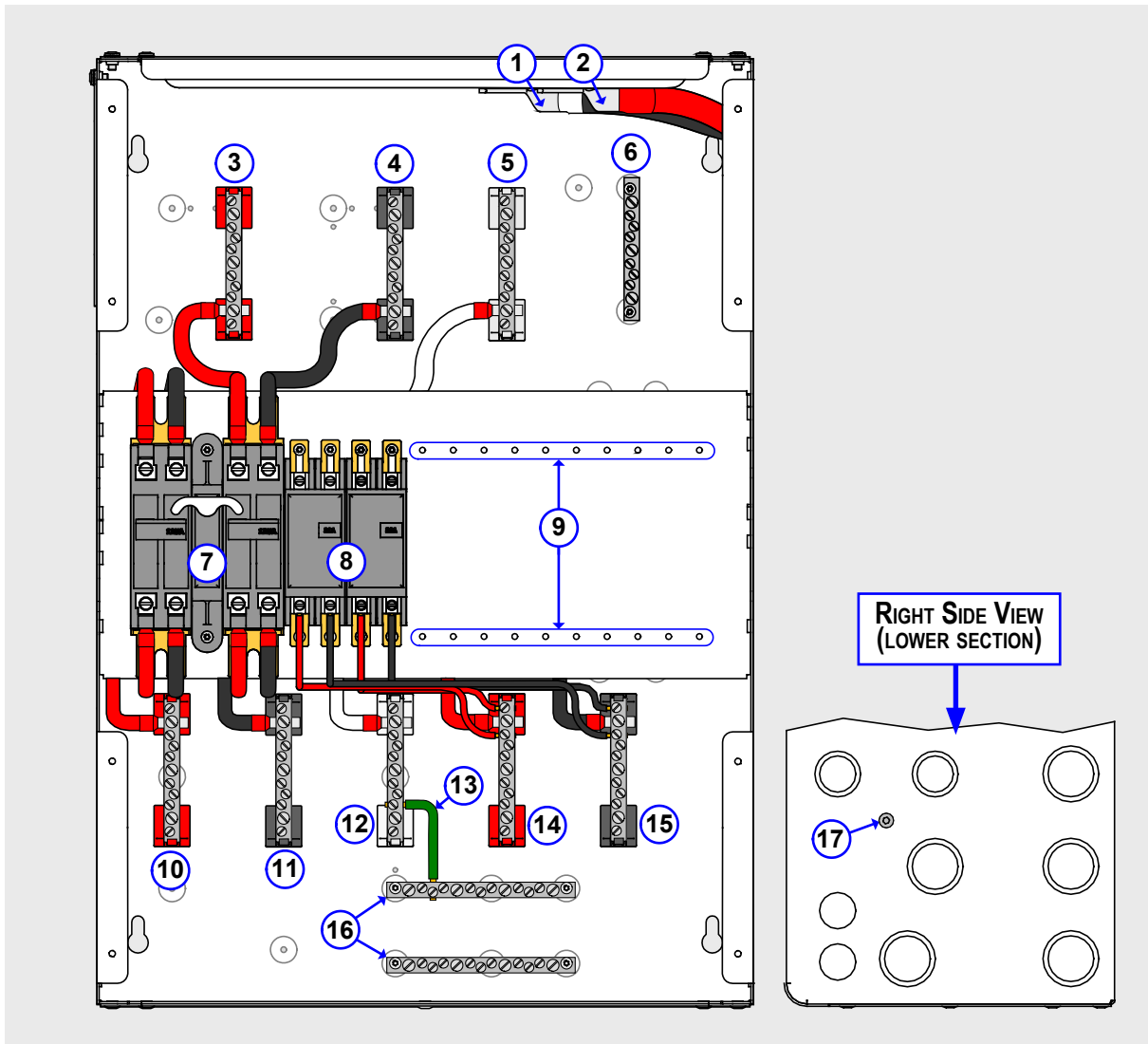

- | | | | |
|---|--|--|--|
| 1 INVERTER'S DC NEGATIVE CONNECTION (CABLE) | 2 INVERTER'S DC POSITIVE CONNECTION (CABLE) | 3 INV HOT 2 OUT BUSBAR (FROM INVERTER OUTPUT) | 4 INV HOT 1 OUT BUSBAR (FROM INVERTER OUTPUT) |
| 5 AC NEUTRAL BUSBAR (INVERTER INPUT/OUTPUT) | 6 AC GROUND BUSBAR (INVERTER INPUT/OUTPUT) | 7 INVERTER BYPASS BREAKER ASSEMBLY (125A) | 8 INVERTER AC INPUT BREAKERS (D30A x2) |
| 9 MOUNTING HOLES, TO ADD INV AC INPUT BREAKERS | 10 AC LEG 2 OUT BUSBAR (TO AC LOAD PANEL) | 11 AC LEG 1 OUT BUSBAR (TO AC LOAD PANEL) | 12 AC NEUTRAL BUSBAR (SOURCE/LOAD IN/OUT) |
| 13 AC NEUTRAL-GROUND CONNECTION | 14 AC LEG 2 IN BUSBAR (FROM GEN OR GRID) | 15 AC LEG 1 IN BUSBAR (FROM GEN OR GRID) | 16 AC GROUND BUSBARS (SOURCE/LOAD IN/OUT) |
| 17 ENCLOSURE JOINING SCREW/WASHER | | | |

Figure 2-10a, MPDH-30D (AC Side) Internal Components

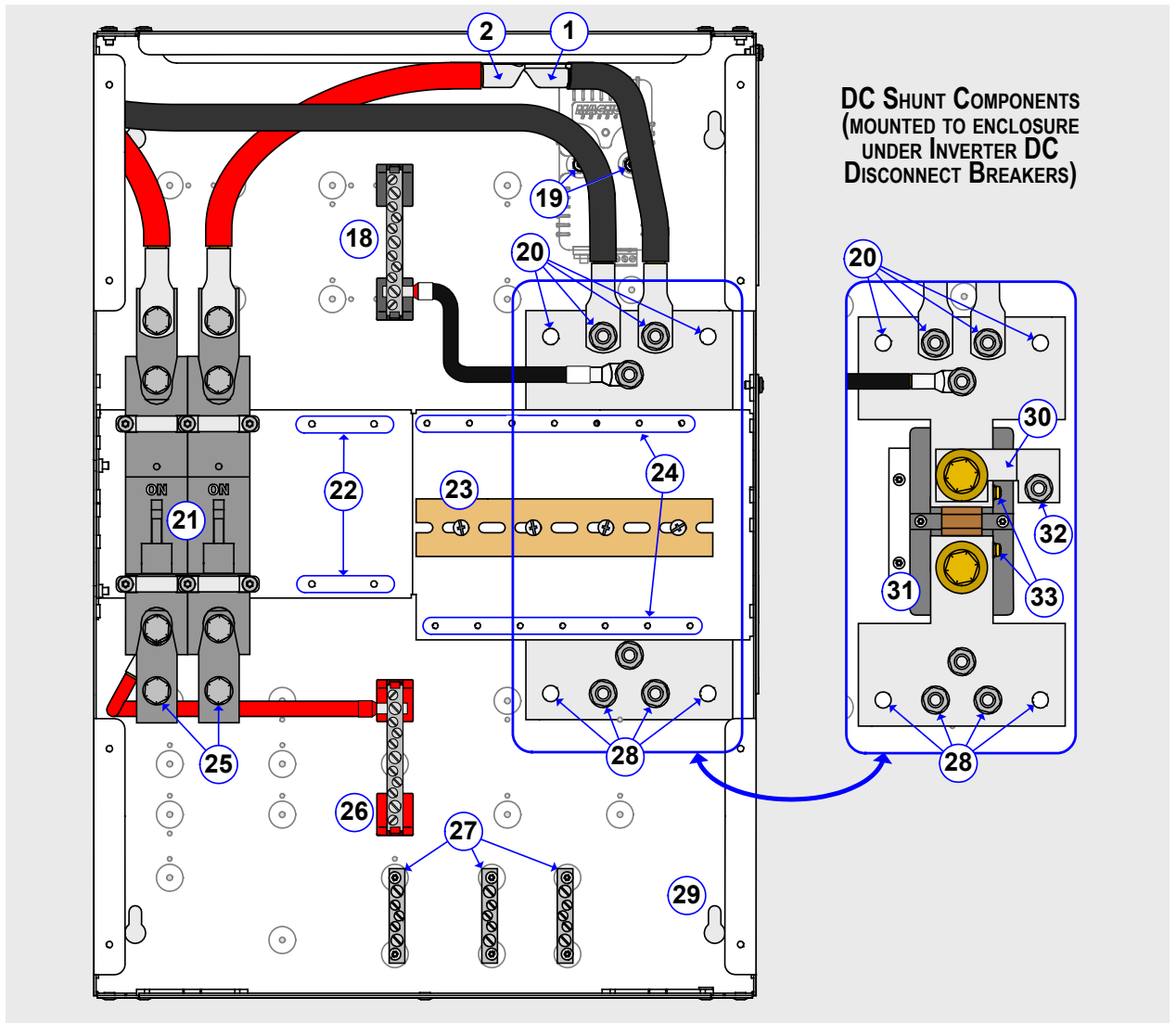

- | | | | |
|---|---|---|---|
| 18 DC NEGATIVE BUSBAR | 19 MOUNTING DIMPLES, BMK (FOR ME-BMK-NS) | 20 INVERTER DC NEGATIVE CONNECTIONS (BUSBAR) | 21 INVERTER DC DISCONNECT BREAKERS (x2) |
| 22 MOUNTING HOLES, INV DC DISCONNECT BREAKER | 23 DIN RAIL TRACK | 24 MOUNTING HOLES, DC BACKMOUNT BREAKERS | 25 BATTERY POSITIVE CONNECTIONS (x2) |
| 26 DC POSITIVE BUSBAR | 27 DC GROUND BUSBARS (x3) | 28 BATTERY NEGATIVE CONNECTIONS | 29 MOUNTING KEYHOLES (X4 FOR EACH ENCLOSURE) |
| 30 DC NEGATIVE-GROUND CONNECTION | 31 DC SHUNT (1000A/100mV) | 32 DC GROUND STUD | 33 DC SHUNT VOLTAGE SENSE TERMINALS/SCREWS |

Figure 2-10b, MPDH-30D (DC Side) Internal Components

3.0 Installation

3.0 Installation

This section describes the requirements and recommendations for installing the MP enclosure.



Info: This installation section primarily explains the installation of one inverter on the MPSL/MPSH enclosure, and two inverters on the MPDH enclosure. When additional inverters are required, the optional MPX enclosures are used. Refer to the MPX Extension Owner's Manual (PN:64-1015) for information on installing these additional inverters.

3.1 Pre-Installation

Before proceeding with the installation:

- Please read and familiarize yourself with the entire Installation section.
- Read and ensure you understand the "Important Product Safety Information" and the "Important Battery Safety Instructions" at the beginning of this manual.
- Be aware of all safety and electrical codes which must be met.
- Inspect all shipping cartons for evidence of physical damage. If a shipping carton is damaged, request that the shipping agent be present for inspection when the carton is opened.
- Unpack the MP enclosure box and remove the components. Verify that you have the components and hardware as listed below in Section 3.1.1 (and shown in Figures 3-1 and 3-2).
- Use the information in Section 3.1.2 to help identify most of the materials and tools required for the installation.
- Read the information provided in Section 3.1.3 to properly plan for the installation.

3.1.1 MP Parts Included

Refer to Figures 3-1 or 3-2 (and the item list below) for your particular MP model to verify the necessary parts are included. If items are missing, contact your authorized Magnum Energy dealer or Magnum Energy.



Info: Save your proof-of-purchase as a record of your ownership; it will be needed if the unit should require in-warranty service.

1a

MPSL or MPSH Models - The MPSL-30D, MPSL-60S, and MPDH-30D use a single enclosure to provide the AC/DC breakers, busbars, and wiring for the inverter's AC and DC circuits.

1b

MPDH Model - The MPDH-30D uses two enclosures, one enclosure (AC Side) provides the AC breakers, busbars, and wiring for the inverters AC circuits; and, the other enclosure (DC Side) provides the DC breakers, busbars, and wiring for the inverter's DC circuits.

2

Inverter Hood - The inverter hood is required to be installed over a Magnum inverter that is mounted on a Magnum Panel to prevent items from falling into the ventilation openings at the top of the inverter. See Section A3 for more information on this hood.

3

Knockout Plate - The knockout plate is provided as an upper conduit plate, or as a safety plate. See Section A5 for more information on this plate.

4

ME-RTR (Router) Bracket Kit - This kit consists of the router bracket and the hardware to attach the ME-RTR (i.e., Router) to the side of the MP enclosure. This kit is not provided with the MPSL-60S model. See Section A4 for more information on this kit.

5

MP Hardware Kit - This hardware kit consists of the Charge Controller bracket and hardware (see Section A1), the owner's manual, communications cables (see Section 3.8), and a front cover label set (see Section 3.15).

6

MP AC Wiring Kit - This wiring kit provides the appropriate AC wires needed to connect the inverter's AC input and output terminals to the MP enclosure. See Section 3.6.3 for more information on this kit.

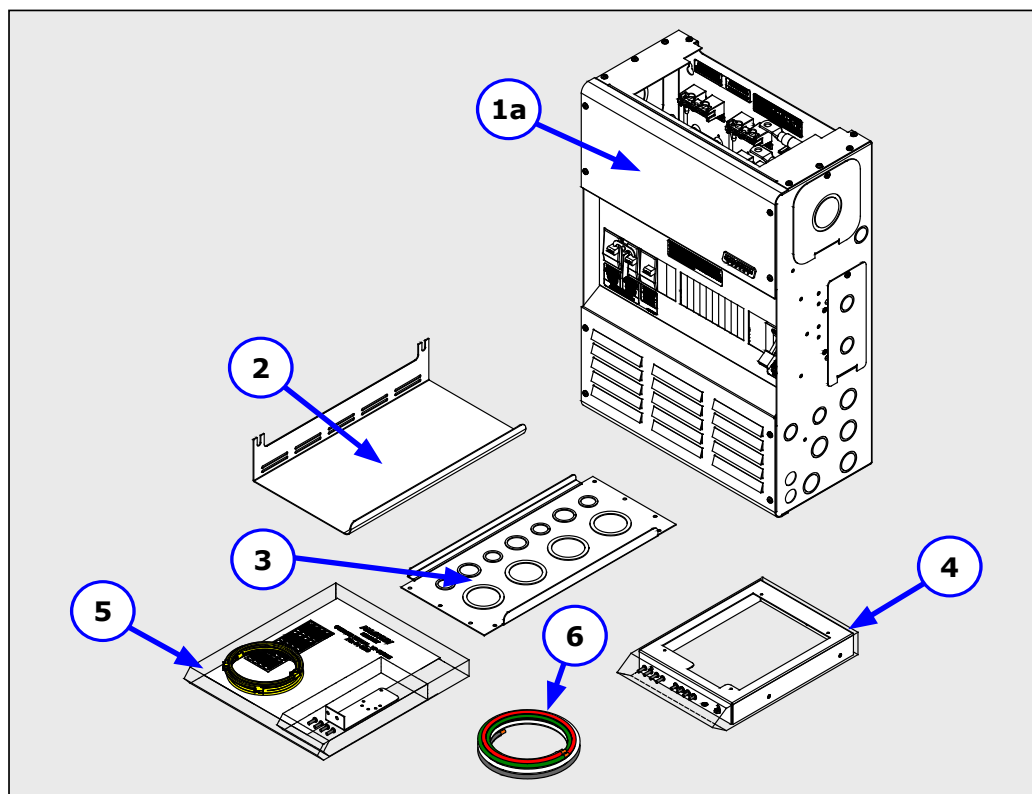

Figure 3-1, Parts Included - MPSL and MPSH Models

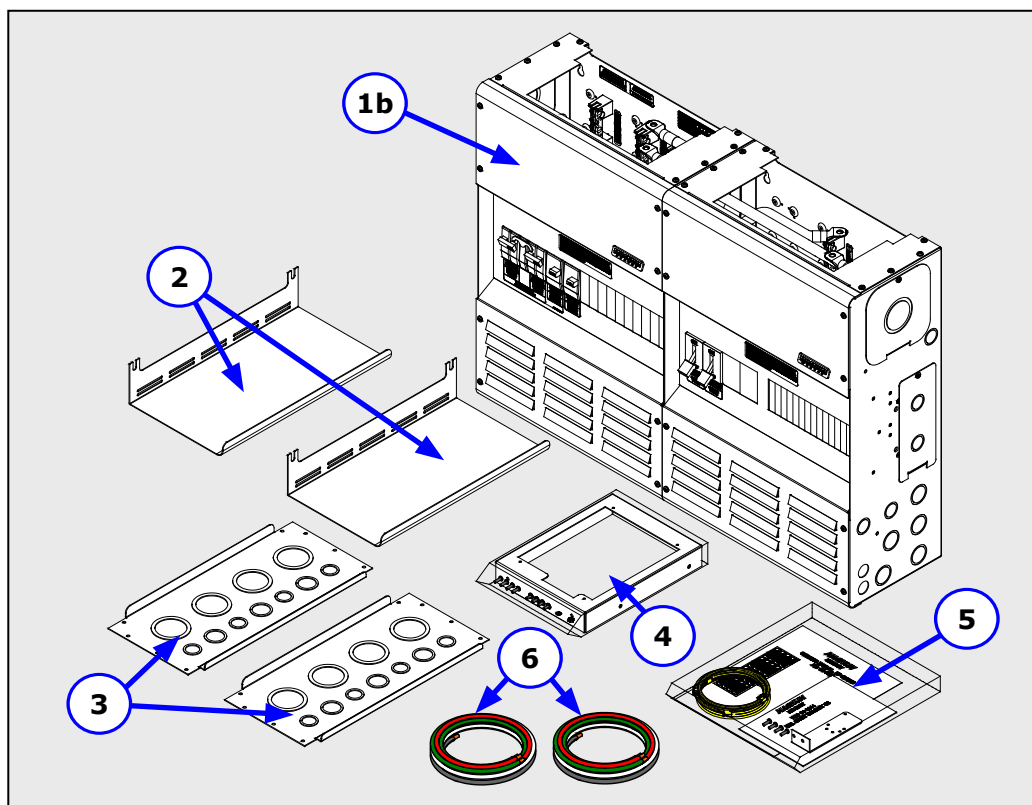

Figure 3-2, Parts Included - MPDH Models

3.0 Installation

3.1.2 Required Material and Tools

The following material and tools may be required for installing this equipment:

Materials

- Conduit, strain-reliefs, and appropriate fittings
- Electrical tape
- Conductors/cables for wiring AC source/load
- Battery cables for wiring to battery bank
- 1/4" mounting bolts and lock washers
- Wire ties
- A strong back
- Conductors for system ground

Tools

- Flat-blade 1/4" screwdrivers
- Phillips screwdriver
- Drill and drill bits
- Torque wrenches
- Torx screwdrivers (T15, T20 and T25 drive)
- Insulated pliers
- Pencil or marker
- 1/2" open end wrench
- Ratchet drives
- Wire cutters/strippers
- AC/DC Voltmeter
- Level

3.1.3 Planning

Installing the MP/inverter system can be fairly straightforward if you take time to plan before turning the first screw. The more thorough you plan, the more time you will save, and avoid common, costly mistakes.

To assist you in planning and designing your installation, review the simplified system diagram shown in Figure 3-3 for parallel-stacked inverter installations, or Figure 3-4 for series-stacked inverter installations. These drawings are a simple overview of the MP/inverter installation. They are not intended to provide detailed information, override or restrict any national or local electrical codes, nor should they be the determining factor as to whether the installation is compliant – that is the responsibility of the electrician and the onsite inspector.



WARNING: Installations should be performed by qualified personnel, such as a licensed or certified electrician. It is the installer's responsibility to determine which safety codes and standards apply, and to ensure that all applicable installation requirements are followed. Applicable installation codes vary depending on the specific location and application of the installation.



Info: Detailed MP/inverter system wiring drawings are provided in Section 4.0, depending on you MP model.

The installation section uses the following steps to perform the MP/inverter installation:

- Find the appropriate location (Section 3.2)
- Prepare the MP enclosure and inverter (Section 3.3)
- Mounting the MP enclosure and inverter (Section 3.4)
- Beware of wiring guidelines/safety (Section 3.5)
- Wire AC circuit (Section 3.6)
- Wire DC circuits (Section 3.7)
- Wire communications cables (Section 3.8)
- Removing negative or neutral to ground connections (Sections 3.9 and 3.10)
- Determine the system ground (Section 3.11)
- Perform a final installation checklist (Section 3.12)
- Perform a functional test (Section 3.13)
- Attach the front covers (Section 3.14)
- Apply external labels (Section 3.15)

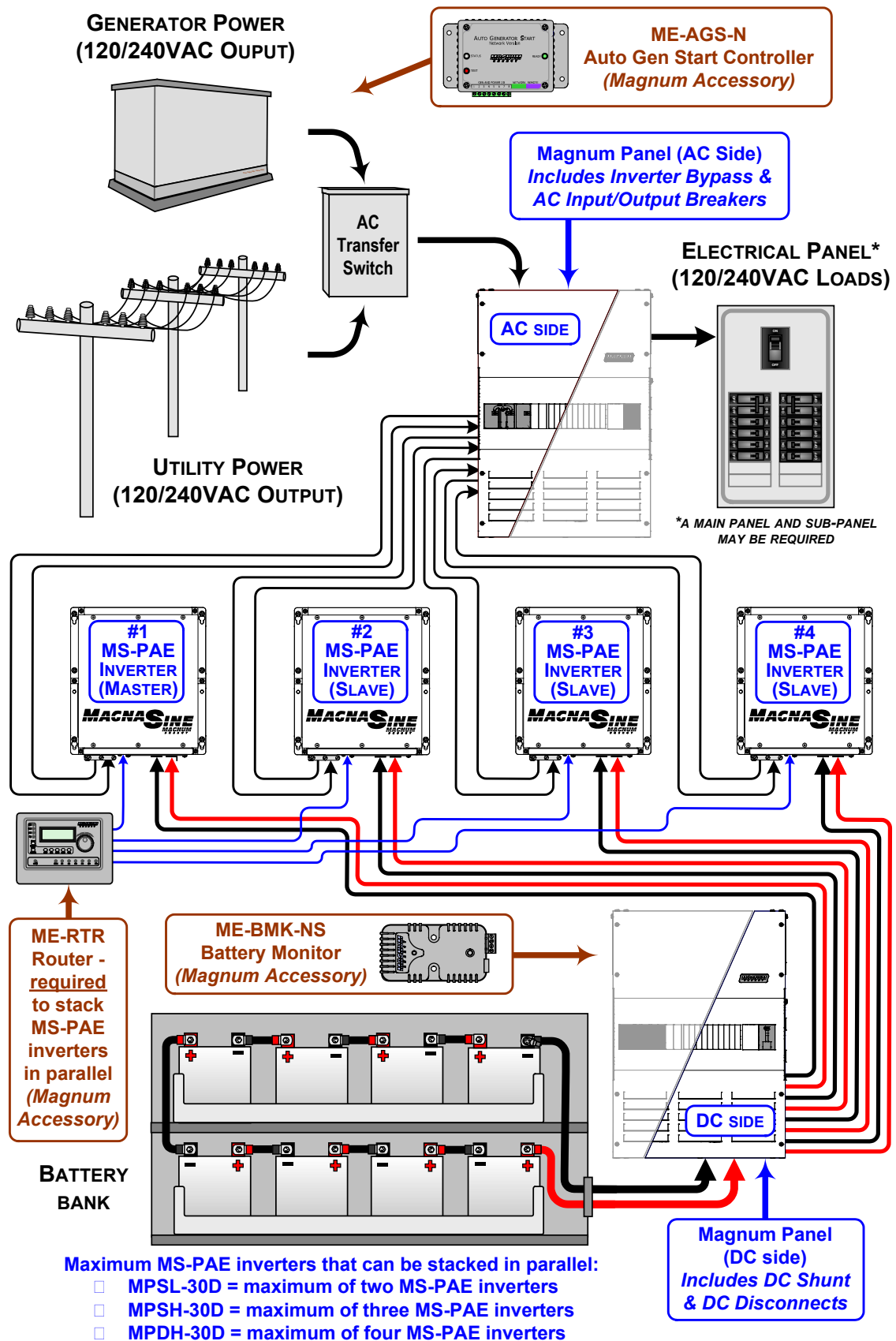

Figure 3-3, MP Series Simplified Parallel-Stacked Installation Diagram

3.0 Installation

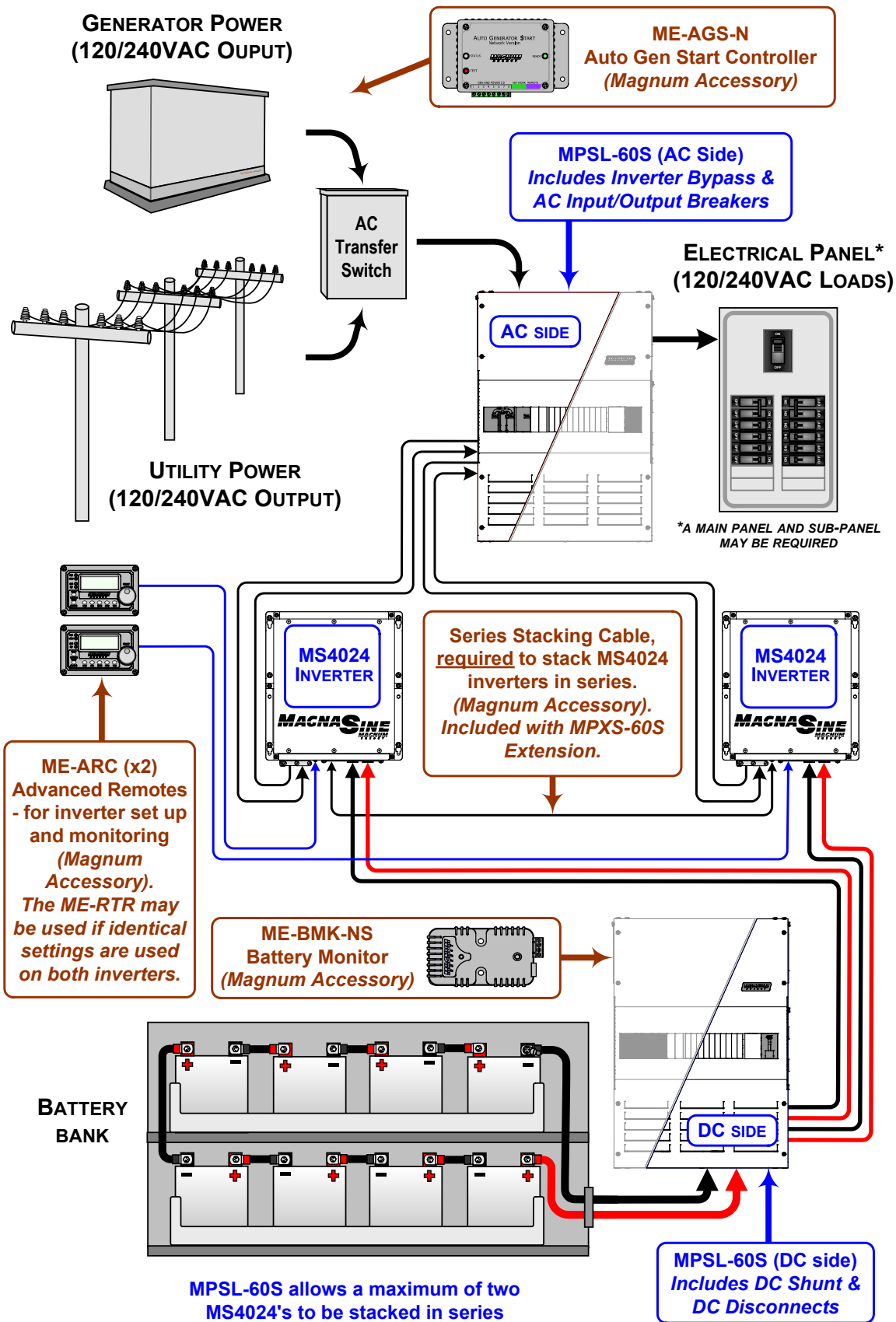

Figure 3-4, MP Series Simplified Series-Stacked Installation Diagram

3.2 Location

Choosing an appropriate location for the MP/inverter system should be determined early in the installation process; install it only in a location that meets the following requirements:

Indoors - The MP/inverter system must be mounted indoors in a relatively clean and dry environment away from sources of high temperature and moisture. The MP enclosure uses plated copper busbars, powder coated metal components, and plated fasteners, which means it is very tolerant to corrosive or condensing environments (one in which humidity and/or temperature change causes water to form on components). However, inverters are complex microprocessor controlled devices and should be treated as sophisticated electronic devices, such as computers or stereo equipment. When selecting the location for the MP/inverter system, don't think of it in the same terms as the other connected equipment, e.g., batteries, generators, etc. When inverters are exposed to a corrosive or condensing environment their life will be shortened, and damage because of corrosion is not covered by the product warranty.

Ventilation - If a Magnum inverter is installed on the MP enclosure, the inverter will pull in air through the intake vents. In order for the inverter to provide full output power and avoid over-temperature fault conditions, do not cover or block the MP enclosure ventilation openings or install it in an area with limited airflow. At the minimum, allow 3 inches of clearance to the left and right of the MP enclosure to provide adequate ventilation.

Close to the Battery Bank - The MP enclosure/inverter system should be located as close to the batteries as possible. This is to ensure the battery cable length is kept short. Long DC wires tend to lose efficiency and reduce the overall performance of an inverter. However, the MP enclosure, the inverter, and any other equipment that can spark (or that corrosion could damage) should not be installed in the same compartment/room as the batteries, or mounted where it will be exposed to gases produced by the batteries. These gases are corrosive and will damage this equipment; also, if these gases are not ventilated and if allowed to collect, they could ignite and cause an explosion. Consult your battery supplier for proper installation requirements.



Info: Consult the inverter owner's manual to determine the proper inverter-to-battery cable size for the distance used. However, this cable must not be sized any smaller than 0000 (4/0) AWG if the DC disconnect breaker in the MP enclosure will also be used as the overcurrent device. If a cable smaller than 4/0 AWG is used, an appropriately sized fuse must be installed to provide overcurrent protection to this smaller cable.

Safe - Keep any flammable/combustible material (e.g., paper, cloth, plastic, etc.) that may be ignited by heat, sparks or flames at a minimum distance of 12 feet away from the MP/inverter system. Do not install the MP/inverter system in any area that contains extremely flammable liquids like gasoline or propane, or in locations that require ignition-protected devices. Sparks from relays, circuit breakers, etc., could ignite the fumes or spills.

Accessible - Do not block access to the front of the MP enclosure. Maintain at least a 36" (91 cm) clear space in front to access the AC and DC wiring terminals and connections inside the MP enclosure, as they will need to be checked and tightened periodically.

RFI - Most inverters can create RFI (Radio Frequency Interference). Keep this in mind when determining the placement of the MP/inverter system. You should locate the MP/inverter system as far away as possible from any electronic equipment susceptible to radio frequency and electromagnetic interference.

Expandability - The MP enclosure was specifically designed to allow multiple inverters to be connected together. Keep in mind as your power needs grow, you can connect additional inverters (using MPX enclosures - up to your models maximum inverter capability) to increase your power capability. Use Figures 3-5 or 3-6 (depending on your MP model) to determine if you are allowing the appropriate vertical and horizontal room to expand your MP/inverter system.

Rodent Proof - Ensure the MP/inverter system is located in an area that prevents rodents and insects from entering and damaging wires/components - the MP/inverter can provide a warm habitat in a cold environment. Mesh screens or nets may need to be installed over any openings to ensure the unit is kept rodent free and well ventilated.

3.0 Installation

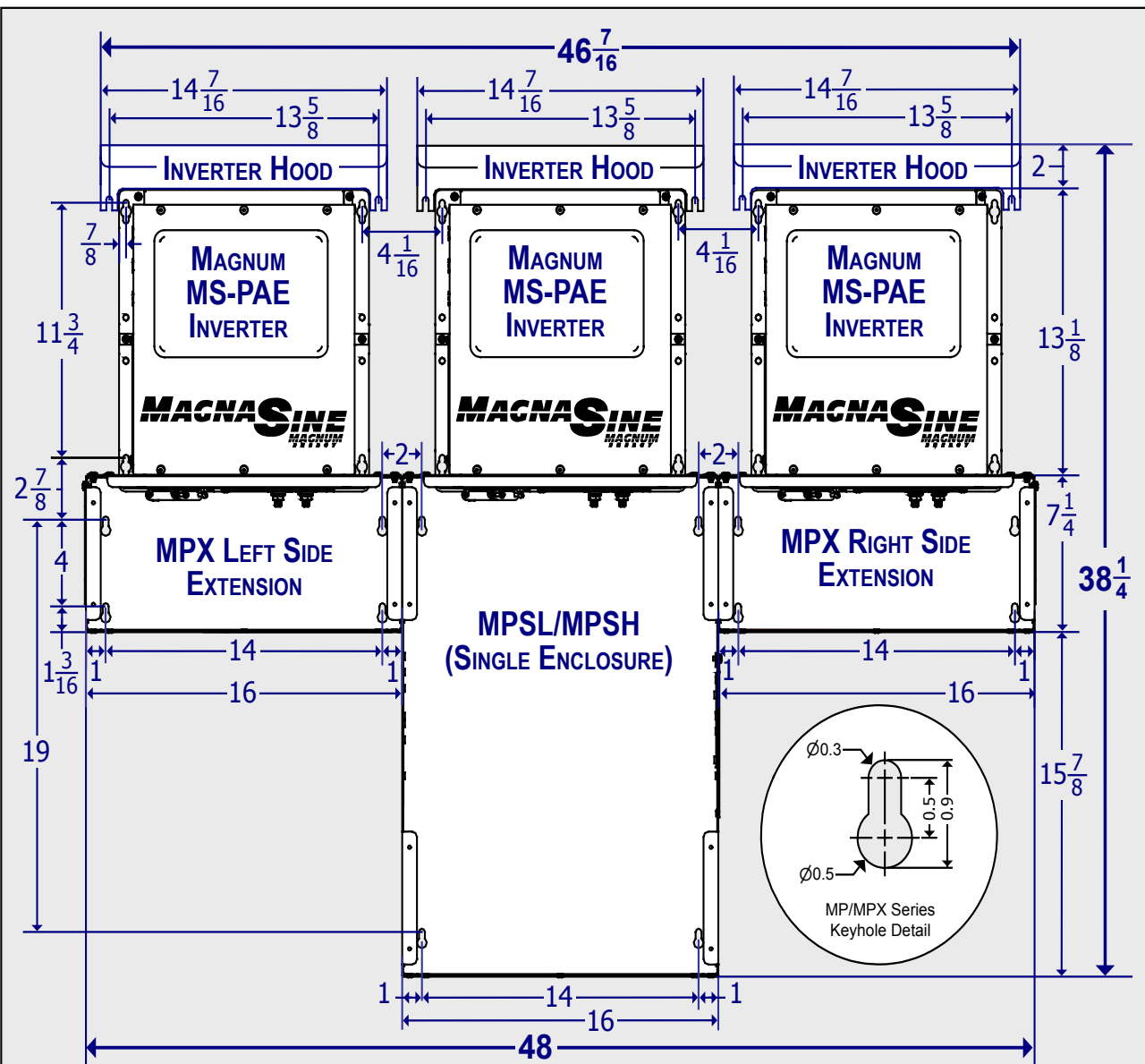

Notes:

1. Lengths shown in inches.
2. MPXL models allow 1-2 inverters and MPXH models allow 1-3 inverters. Installations using one inverter do not require a MPX extension, two inverters require one MPX extension, and three inverters require two MPX extensions.
3. To meet UL regulatory requirements, an inverter hood must be installed above each Magnum inverter that is mounted on the Magnum Panel (vertically).

Figure 3-5, System Dimensions (Single Enclosure)

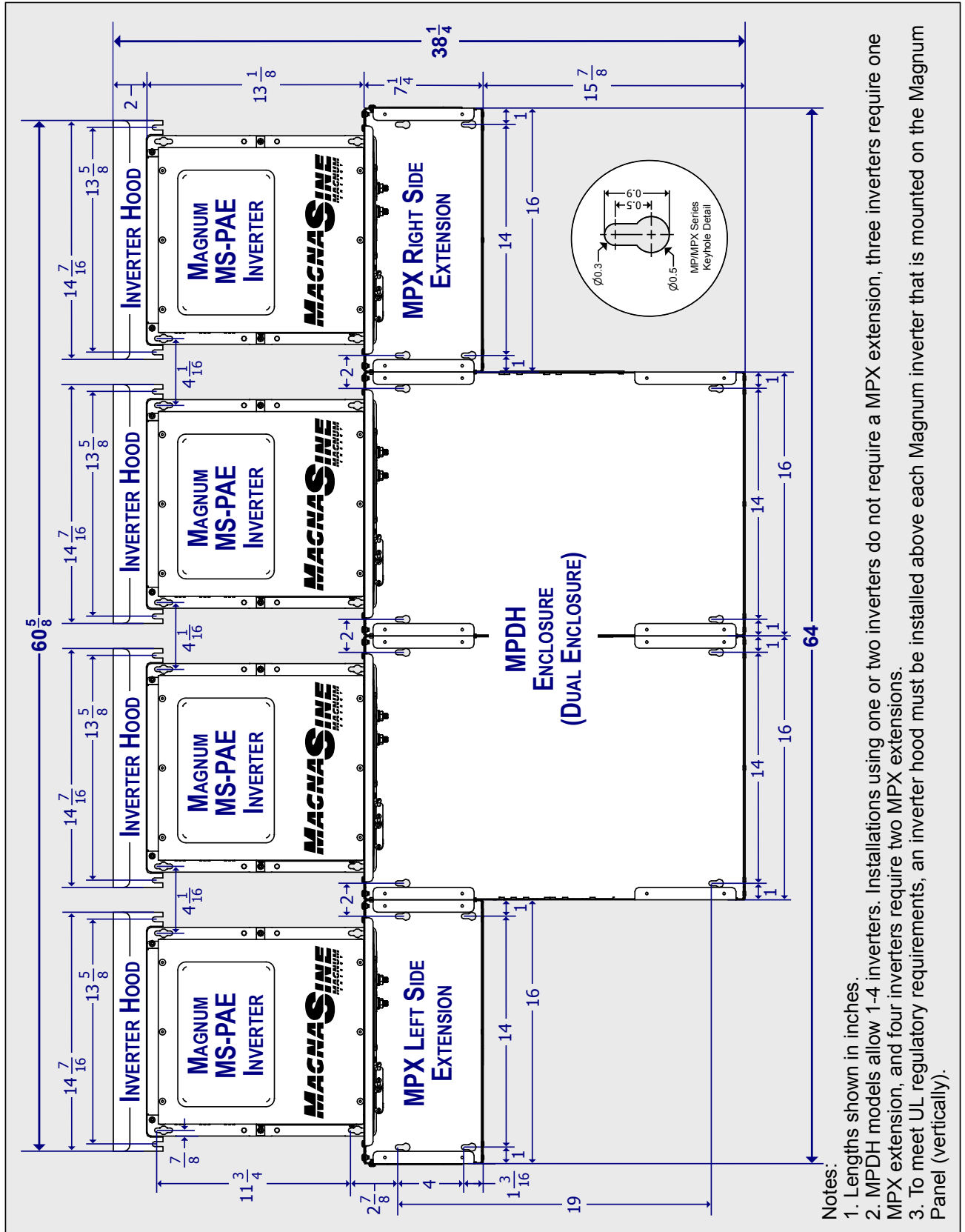

- Notes:
1. Lengths shown in inches.
 2. MPDH models allow 1-4 inverters. Installations using one or two inverters do not require a MPX extension, three inverters require one MPX extension, and four inverters require two MPX extensions.
 3. To meet UL regulatory requirements, an inverter hood must be installed above each Magnum inverter that is mounted on the Magnum Panel (vertically).

Figure 3-6, System Dimensions (Dual Enclosure)

3.0 Installation

3.3 Preparing the MP Enclosure and Inverter

Prior to mounting any component, the installation will be easier if you prepare the MP enclosure and the Magnum inverter by performing the following:

- Remove the MP enclosure front cover as described in [Section 3.3.1](#).
 - Remove the appropriate conduit knockouts as described in [Section 3.3.2](#).
- Note:** It is much easier to access the enclosure sides and remove the knockouts if the enclosure is sitting on a bench, rather than trying to remove the knockouts while the enclosure is mounted.
- Connect and separate the inverter's AC input and output wires as described in [Section 3.3.3](#). When installing multiple inverters, access to the inverter's AC terminals is limited, so take the time to connect the wires and separate the wires prior to mounting the inverter.

3.3.1 Removing the Front Cover

To remove the front cover on each enclosure, use a T25 Torx screwdriver to unscrew the eight upper and lower screws/washers as shown in Figure 3-7. The screws are #10-32 x 3/8" Pan head, T25 Torx drive, thread cutting screws and the washers are #10 external tooth star-washers.

The single MP enclosures (MPSL-30D, MPSL-60S, and MPSH-30D) use eight screws/washers to hold the front cover in place, see Figure 3-8. The dual MP enclosure (MPDH-30D) also uses eight screws/washers to hold each front cover in place (sixteen total), see Figure 3-9.

Important: On the AC side of the MPDH-30D, there is a #10-32 x 3/8" Torx screw (T25 drive). It is screwed into the right side (see Item 17, Figure 2-10a). It is used to join the two enclosures together and must be removed prior to mounting (see Figure 3-16c).

Important: On some versions of the MP enclosure there are eight Truss head, Torx drive screws in the middle (see Figure 3-7). **DO NOT** remove these middle screws to remove the front cover. These screws are used to hold the top, middle and bottom sections of the front cover together, and help align the knockout openings when additional breakers are installed (refer to Section A8).

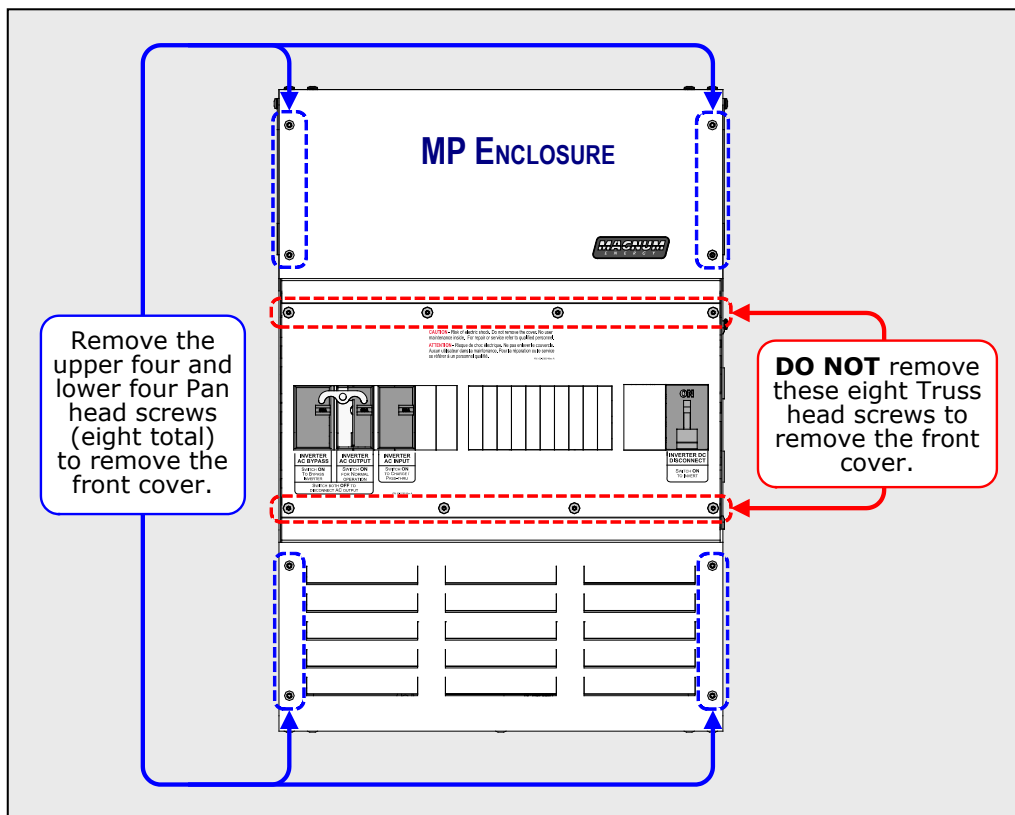

Figure 3-7, Front Cover Screws to Remove

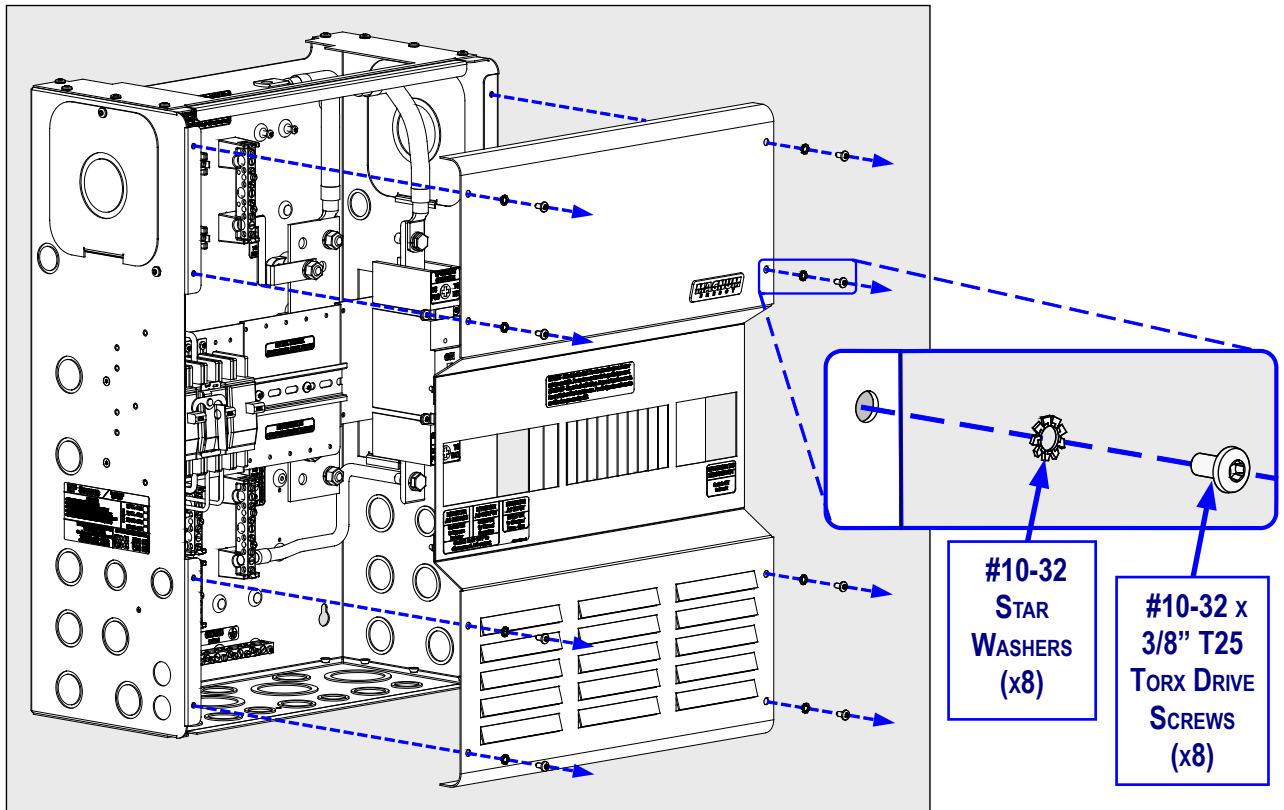

Figure 3-8, Removing Front Cover - Single Enclosure

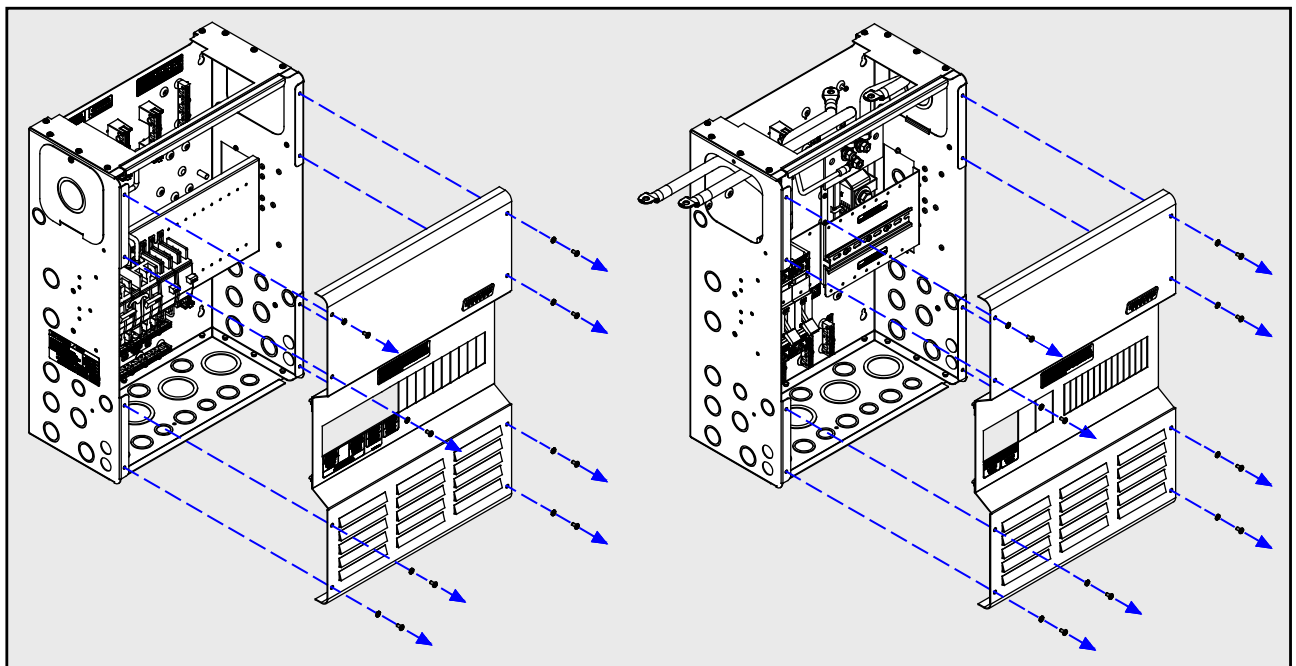

Figure 3-9, Removing Front Covers - Dual Enclosure

3.0 Installation

3.3.2 Planning Wire/Conduit Runs and Removing Knockouts

The MP enclosure is designed to provide ample room for wiring and comes standard with knockouts to facilitate conduit installation for wire runs. See Figure 3-13 or 3-14 (depending on you model) to see the size and location of these conduit knockouts. The 1/2", 3/4", and 1" knockouts are normally used for the AC circuits, PV array, DC loads, and other smaller input cables. The 1 1/2" and 2" knockouts are used to connect to the battery bank. Remove the appropriate knockout close to the terminal where that wire connects, or whichever one works for the way your field wiring comes in.

Before removing any knockout, review Figure 3-10 and think about all the wiring required and where you are going to route the different circuits; such as:

- Wiring from the MP enclosure to the AC loads (AC sub-panel)
- Wire runs from the AC source (utility and/or a generator) to the MP enclosure
- Battery cable wiring from the battery bank to the MP enclosure
- Additional wiring from any external DC source (PV, wind, or hydro) to the MP enclosure
- Small signal wiring (remote controls, battery monitoring, auto gen starting)
- PV array and charge controller wiring
- Attaching lightning arrestors

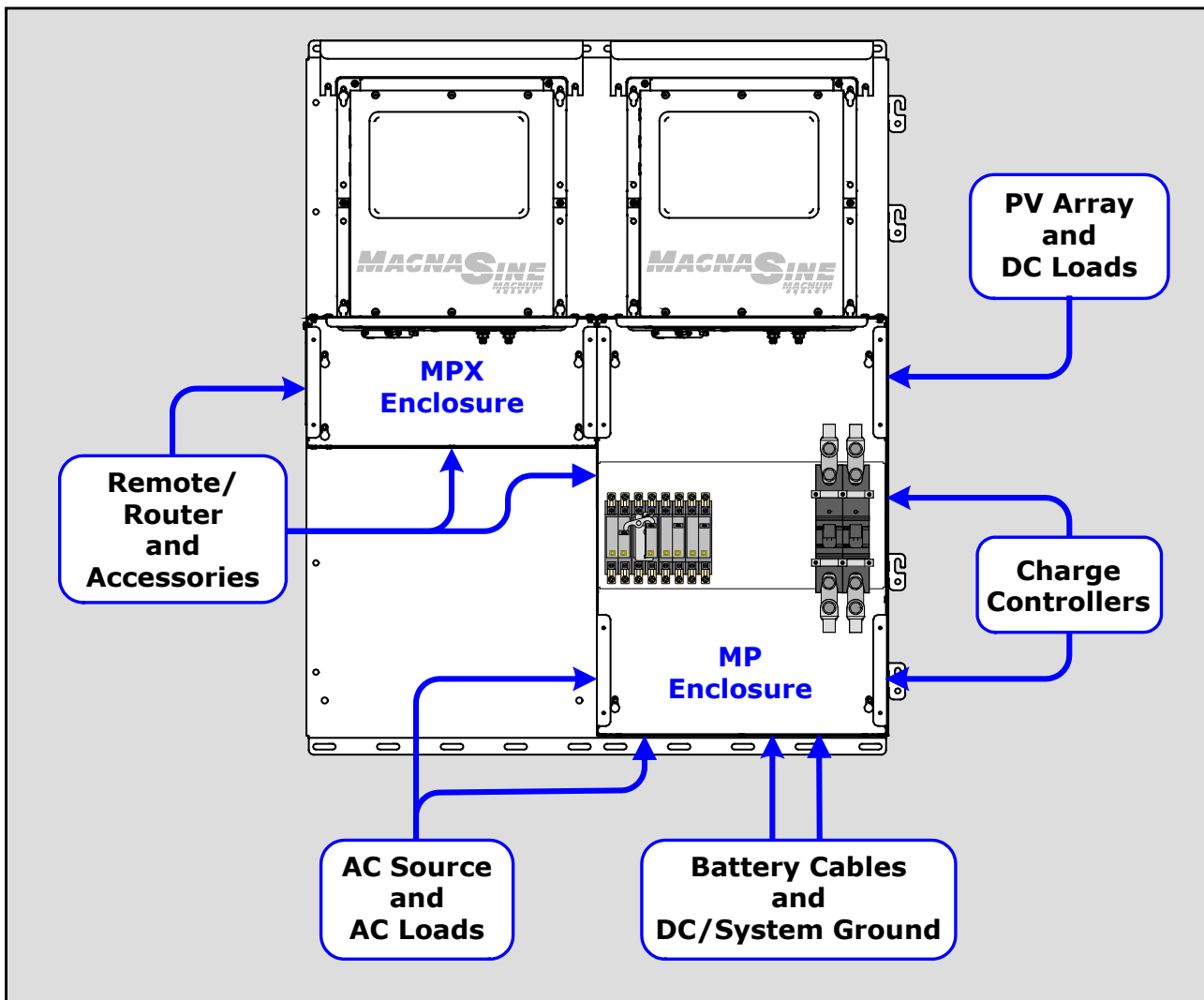

Figure 3-10, Conduit/Wire Routing

As shown in Figure 3-11, remove the knockouts by tapping the edge with a straight bladed screwdriver and a hammer, then twist out with pliers. Ensure no debris remains inside the MP enclosure after removing the knockouts.

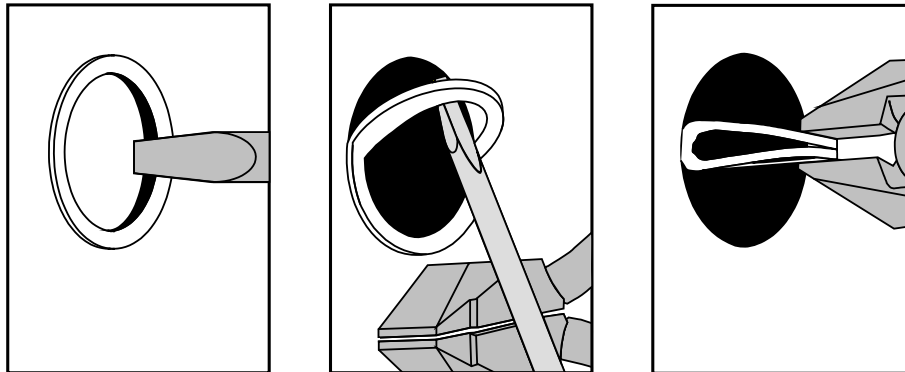

Figure 3-11, Removing Knockouts

3.3.3 Connect and Separate Inverter AC Wires

Before mounting the inverter on the MP enclosure, we highly recommend using the wires provided in the MP AC Wiring Kit (Item 6, Figures 3-1 and 3-2) and connecting them to the inverter's AC wiring terminals (see Figure 4-1 for MS4024 inverters, Figure 4-2 for MS-PAE Series inverters, or refer to the inverters owner's manual). It is possible to connect these wires after the inverter is mounted, but space and access is limited - especially when installing multiple inverters side-by-side on an MP enclosure system.

When connecting the inverter's AC input and output wires, take time to separate the wires into two bundles (AC input and AC output), and route each bundle thru different strain-reliefs on the inverter as shown in Figure 3-12. This will help to ensure they are connected to the correct terminals in the MP enclosure after the inverter is mounted. Refer to Table 3-3 for information on each wire in the AC wiring kit and where they are used.



Info: Once the AC wires are connected inside the inverter, ensure the AC wiring access plate is reattached before mounting the inverter on the MP enclosure.

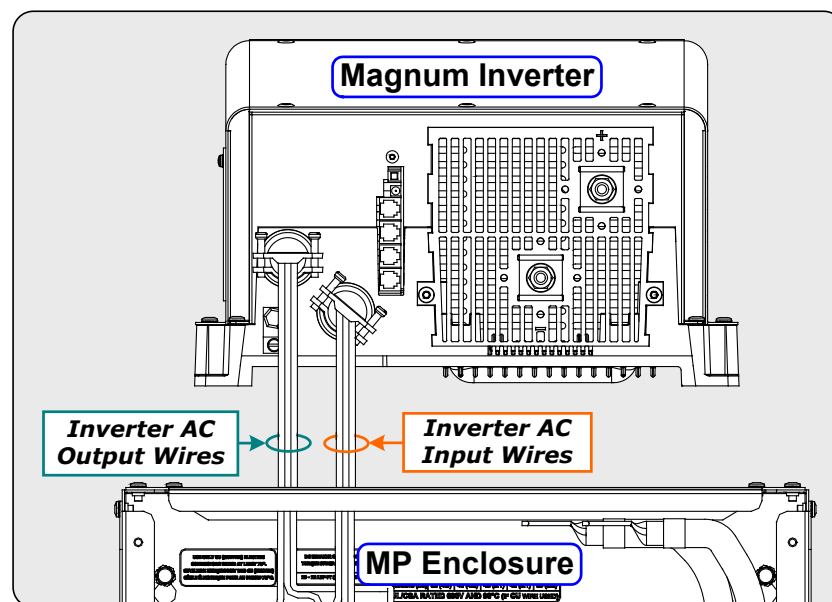

Figure 3-12, Connect and Separate Inverter AC Wires

3.0 Installation

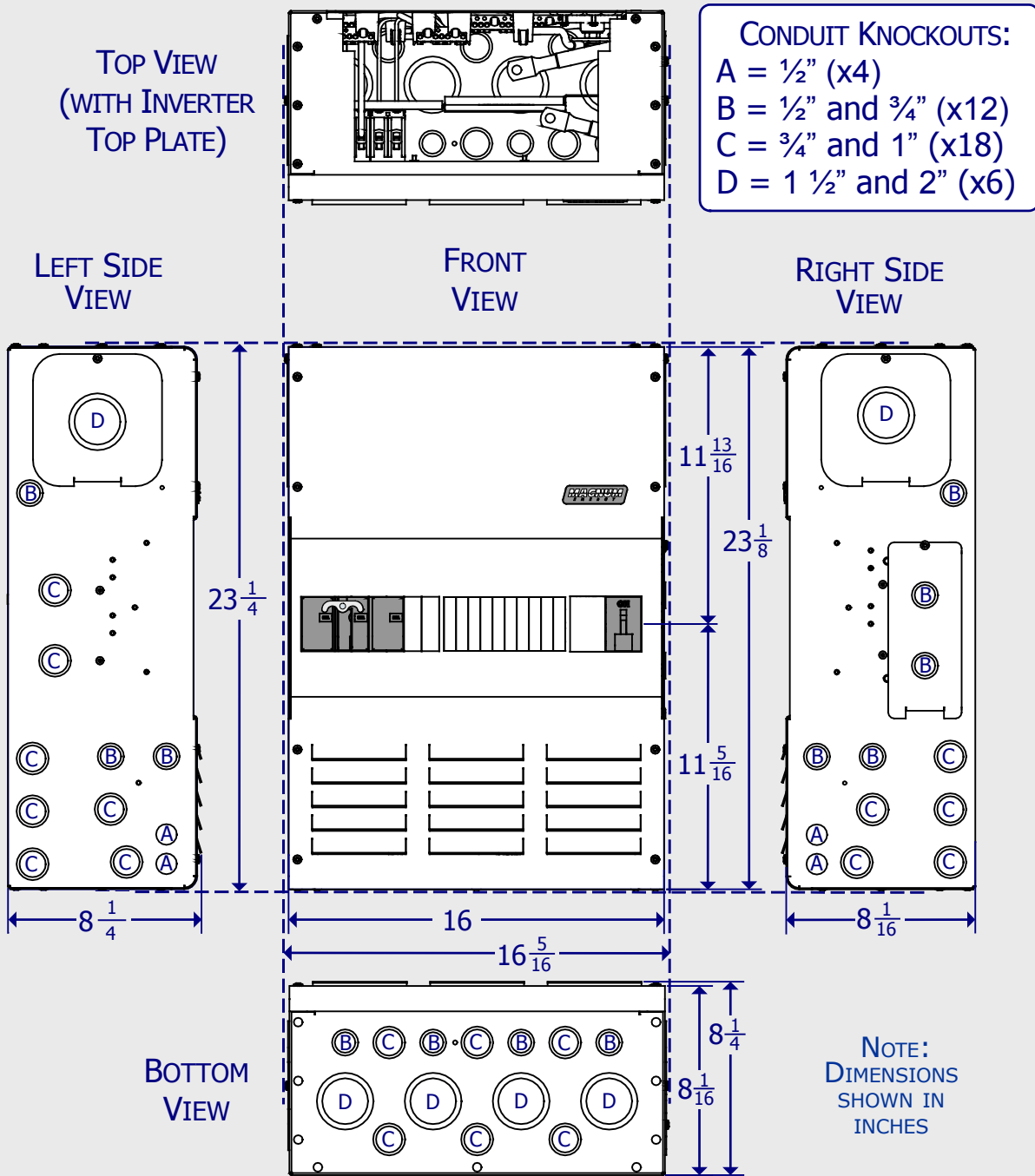

Figure 3-13, MPSL/MPSH Dimensions and Knockout Location/Sizes

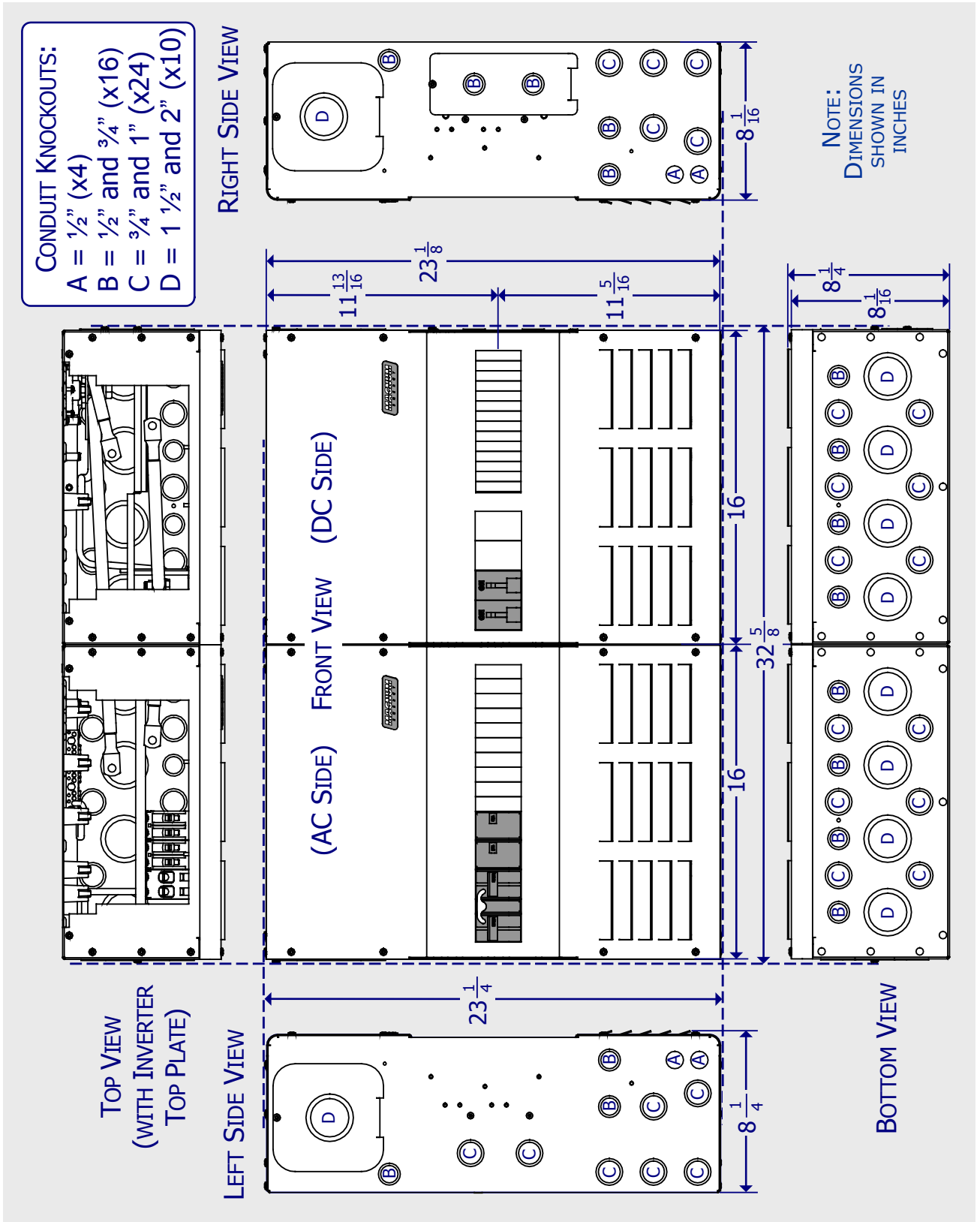

Figure 3-14, MPDH Dimensions and Knockout Location/Sizes

3.0 Installation

3.4 Mounting the MP/Inverter System

Be careful to note the height at which you want to locate the MP and inverter to ensure you can access any controls and wiring terminals. Use Figure 3-5 or 3-6 to determine the mounting keyhole locations, or use the base of the MP enclosure as a template to mark the mounting screw locations. After marking the mounting screw locations, secure the MP enclosure to an appropriate solid non-combustible* vertical surface using appropriate mounting hardware. The mounting keyhole slots on the MP enclosure will accept up to a maximum 1/4" screw/bolt.

The MP enclosure must be mounted on a vertical surface (on a wall) in an upright position to meet regulatory requirements and to ensure the DC breakers operate properly. The surface and mounting hardware must be capable of supporting at least three times the combined weight of all the components mounted (i.e., MP enclosure, inverter, and any other accessories). When considering the strength of the support surface, remember each MP enclosure with inverter can weigh up to 120 lbs. (54 kg). Once the MP enclosure is firmly secured, set the Magnum inverter into the top of the MP enclosure and secure it to the mounting surface.

If mounting the MPDH-30D, ensure the two enclosures (AC and DC sides) are mechanically and electrically connected by screwing them together as shown in Figure 3-16c.



WARNING: The MP enclosure is heavy. Use proper lifting techniques during installation to prevent personal injury.



CAUTION: When a Magnum inverter is installed vertically, the inverter hood (Item 2, Figures 3-1 and 3-2) must be installed over the top of the inverter to prevent objects falling into the inverter's vent openings.



Info: Magnum has two mounting backplates that provide a suitable non-combustible surface and the required support for mounting MP enclosures, MPX enclosures, and Magnum inverters together. The BP-S is the single backplate, and the BP-D is the dual backplate. Hardware to mount the MP enclosure is provided with either backplate.

* The Magnum inverter base can reach a temperature up to 194°F (90°C) and is required to be mounted on a non-combustible surface. A non-combustible surface is one made of material that will not ignite, burn, support combustion, or release flammable vapors when subjected to fire or heat as per the ASTM E136 standard. For the most part, these are materials that are largely comprised of inorganic materials such as stone, steel, iron, brick, tile, concrete, slate, and glass. Common building materials such as gypsum board as well as any paint, wall coverings, and certainly wood will not pass.

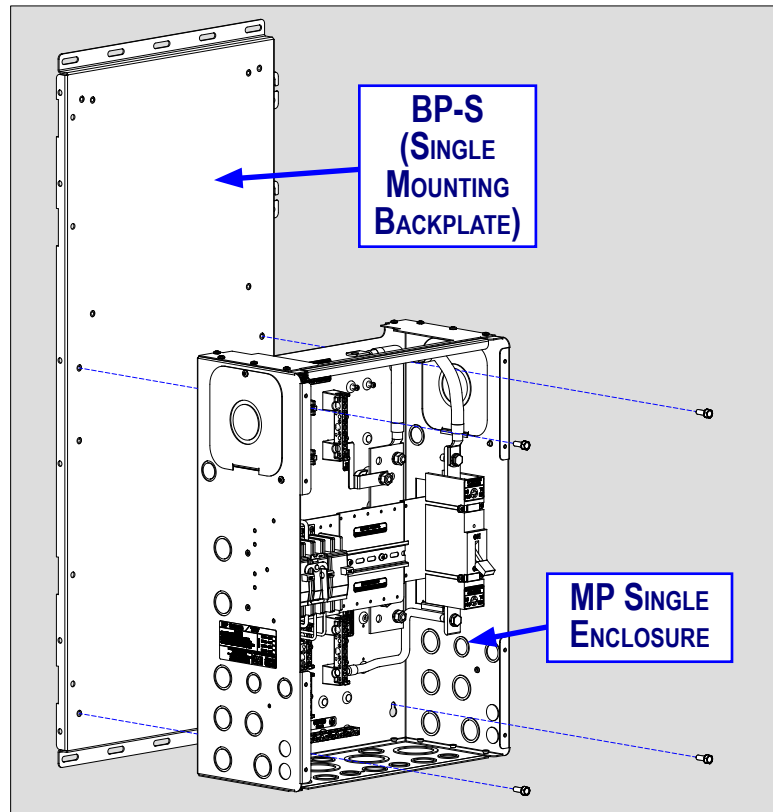

Figure 3-15a, Mounting the MP Single Enclosure

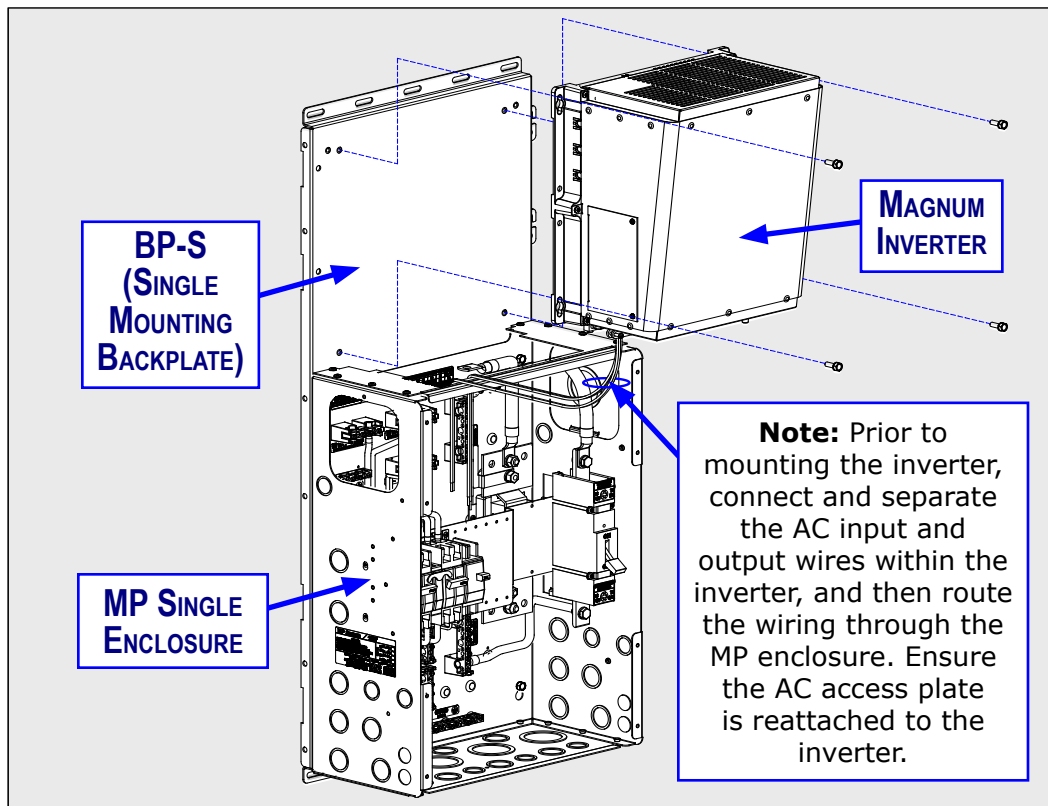

Figure 3-15b, Mounting Inverter - MP Single Enclosure

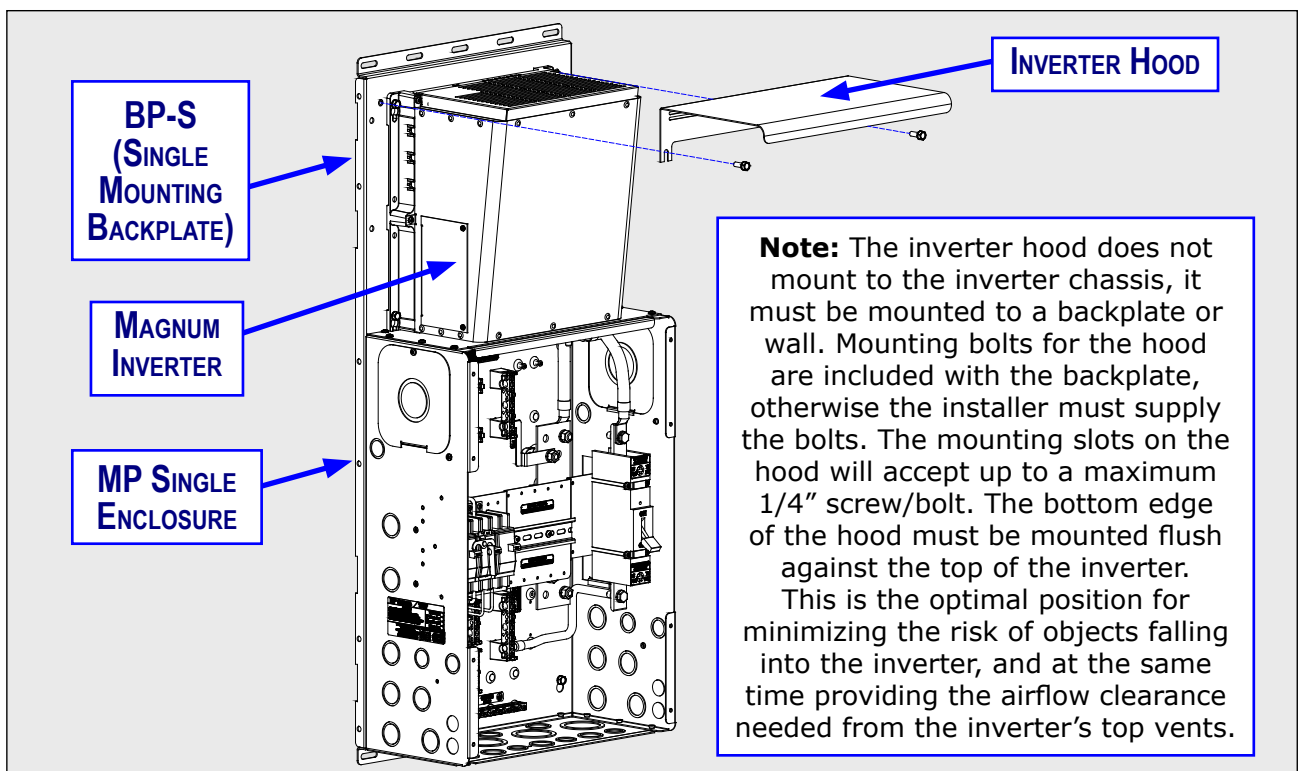

Figure 3-15c, Mounting Inverter Hood - MP Single Enclosure

3.0 Installation

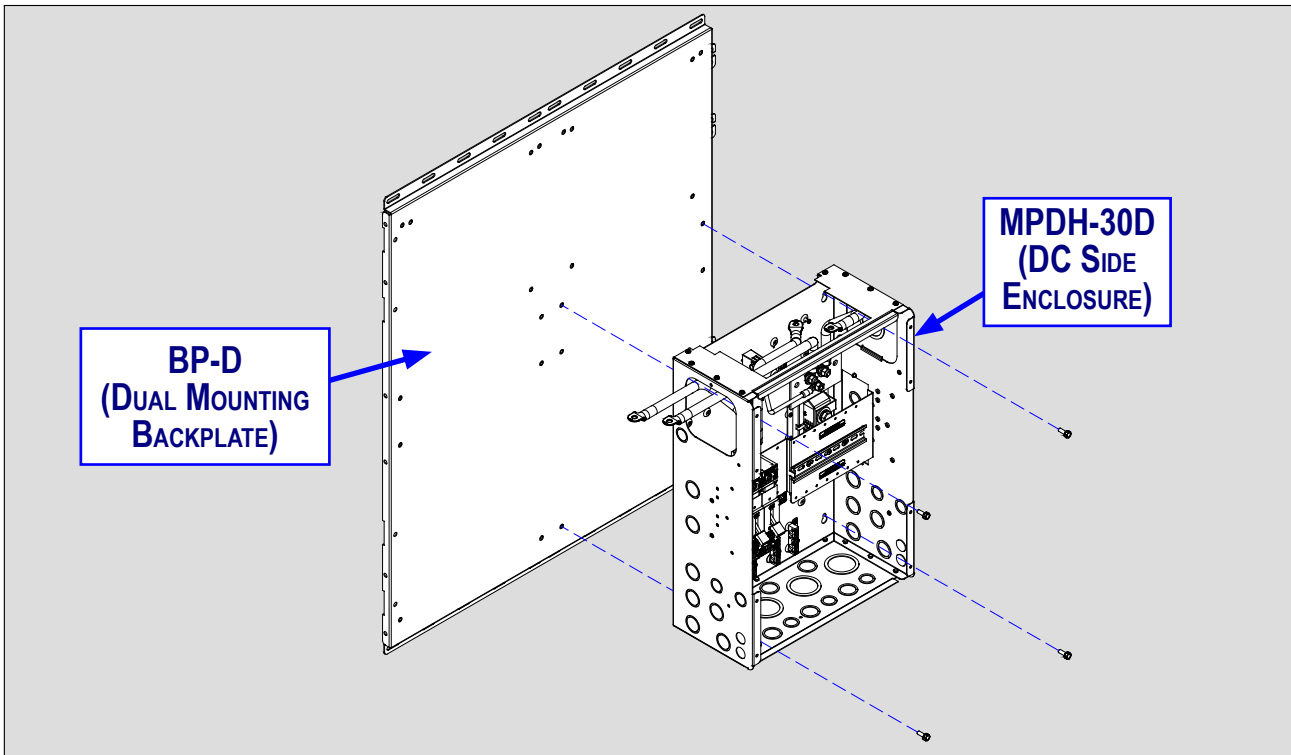

Figure 3-16a, Mounting the MP Dual Enclosure (DC Side)

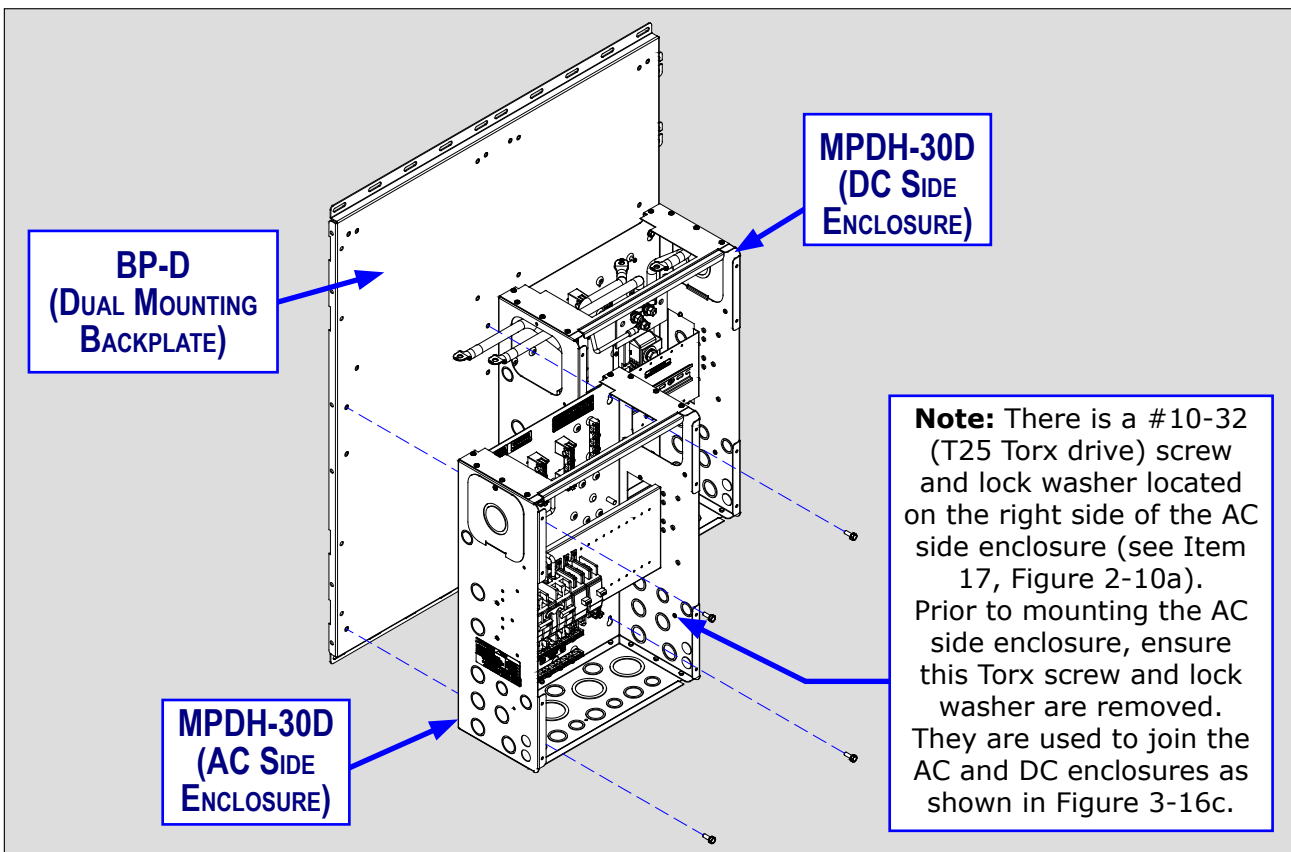

Figure 3-16b, Mounting the MP Dual Enclosure (AC Side)

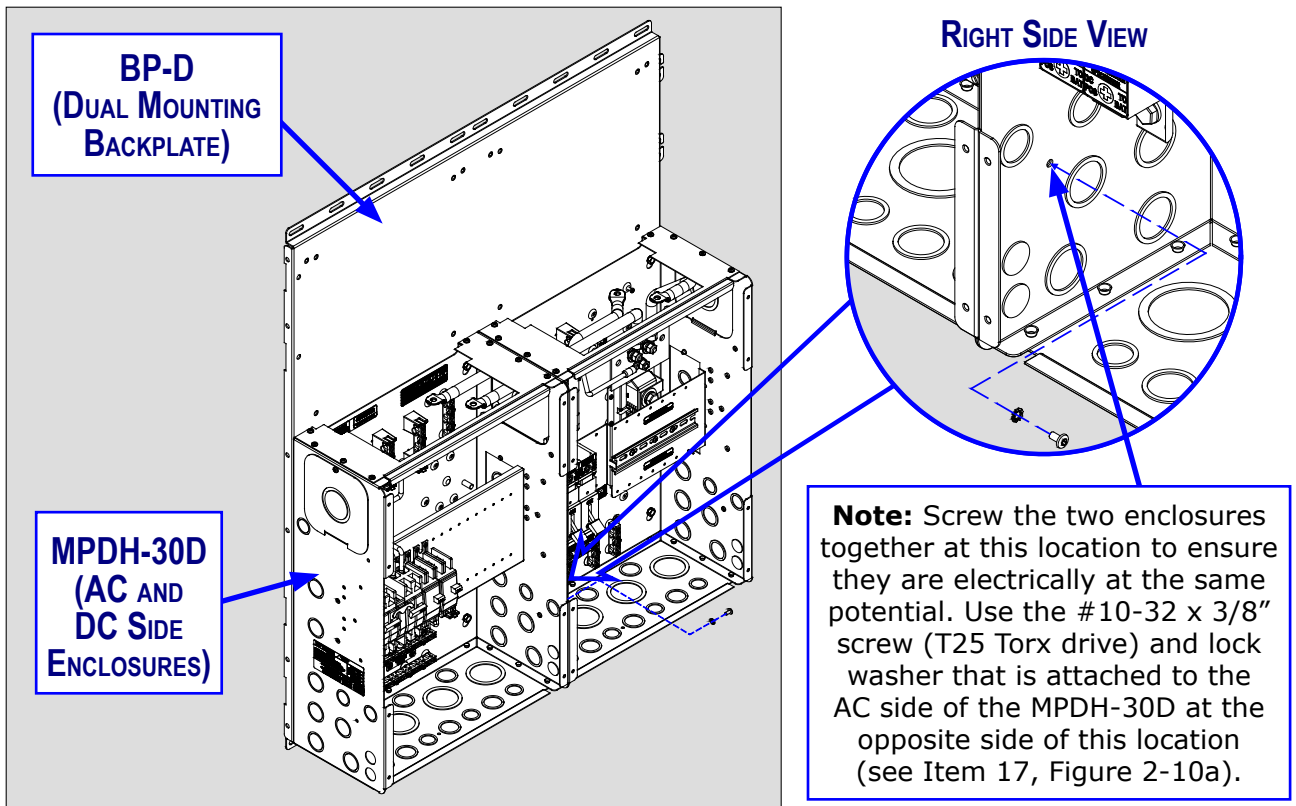

Figure 3-16c, Connecting the Two Sides Together - MP Dual Enclosure

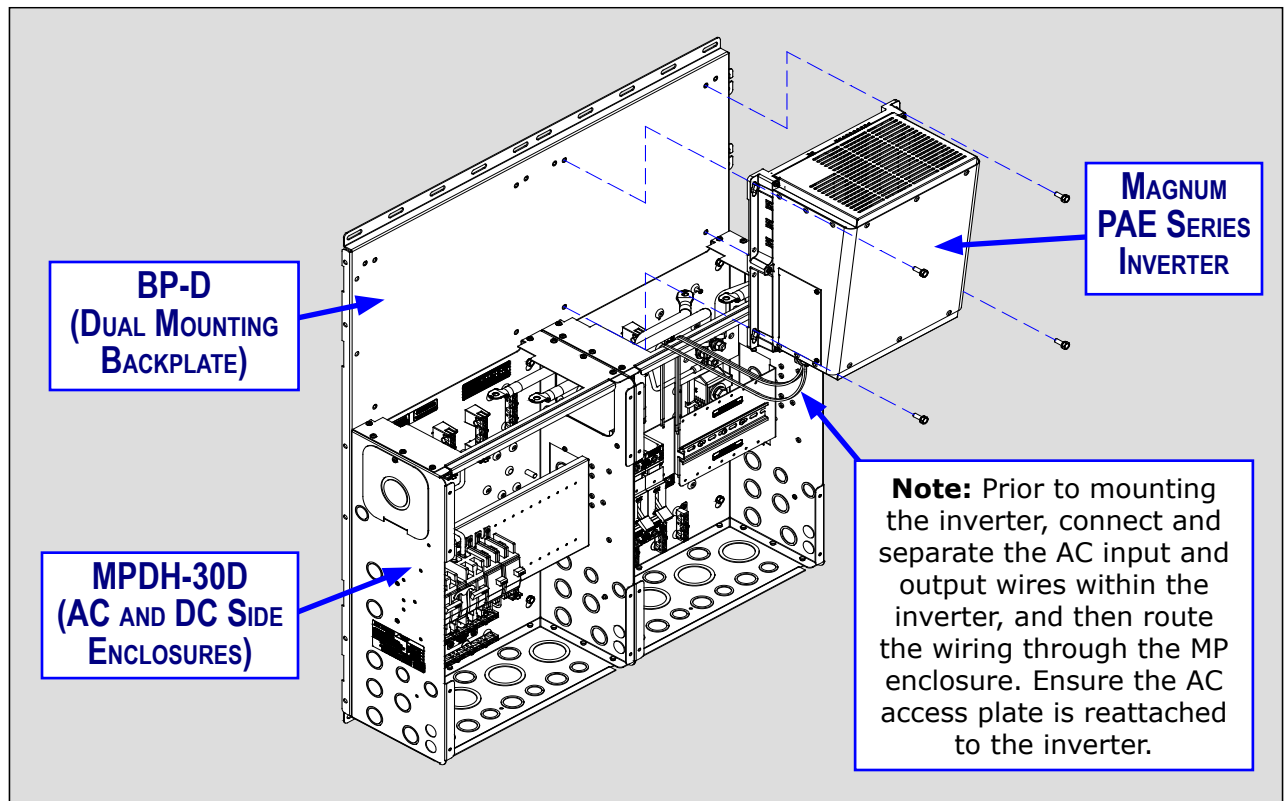

Figure 3-16d, Mounting First Inverter - MP Dual Enclosure

3.0 Installation

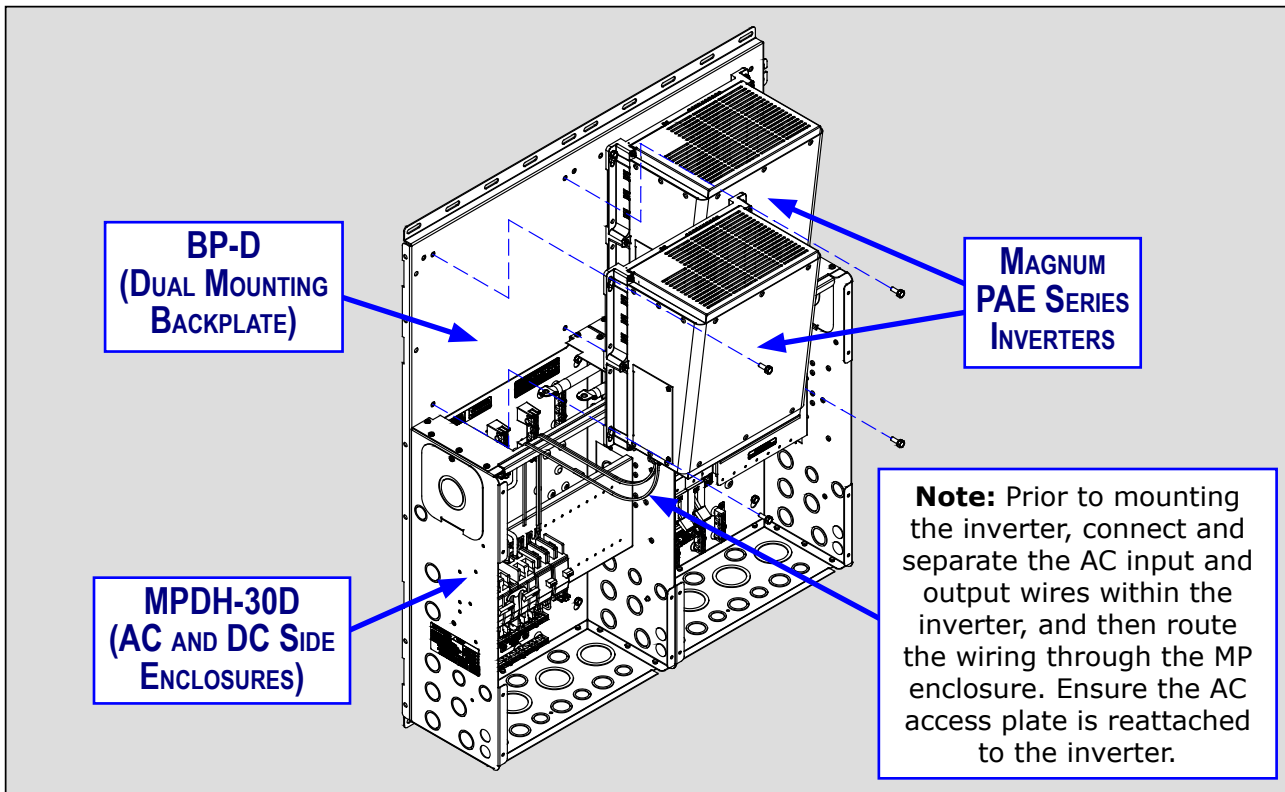

Figure 3-16e, Mounting Second Inverter - MP Dual Enclosure

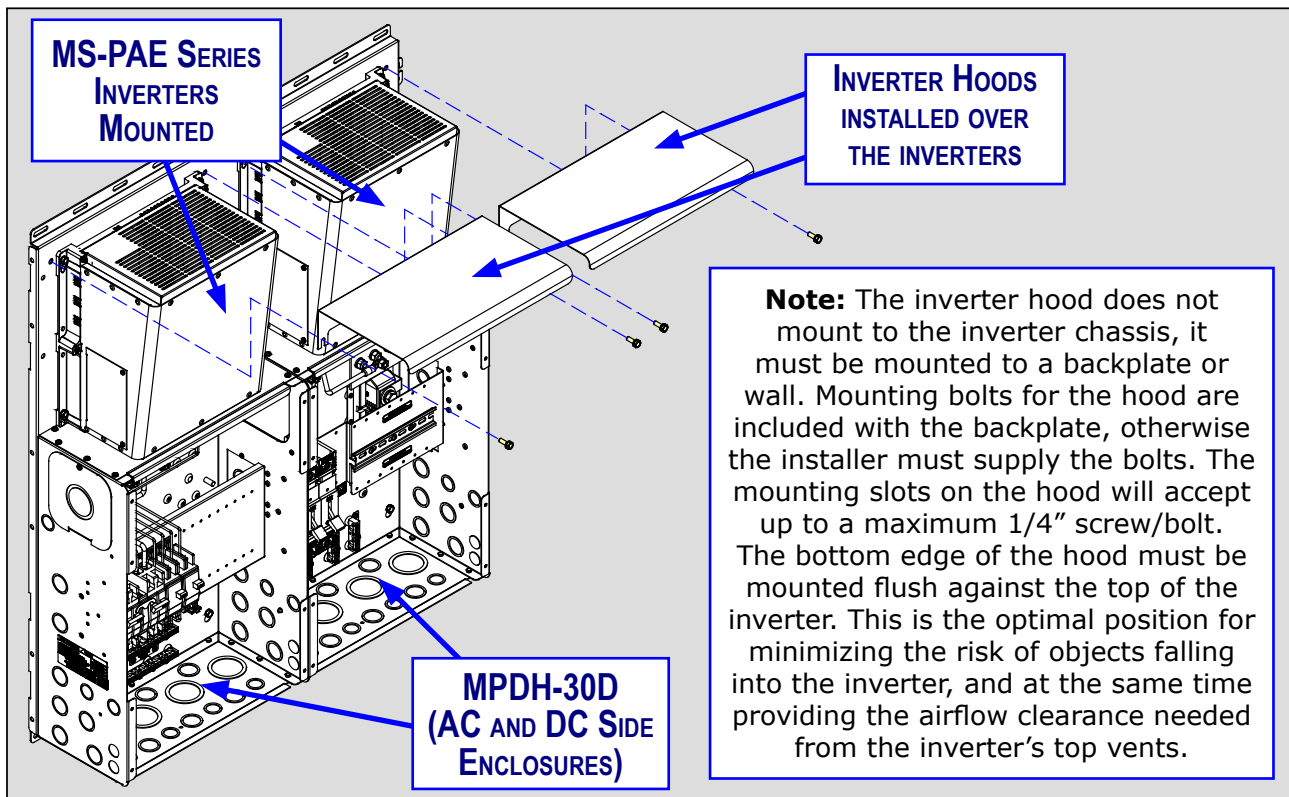

Figure 3-16f, Mounting the Inverter Hoods - MP Dual Enclosure

3.5 Wiring the MP Enclosures

This section describes the requirements and recommendations for wiring to/from the MP enclosure. Read all instructions before wiring the MP enclosure.

IMPORTANT: The installation of this MP enclosure/inverter system must meet all local codes and standards and be performed by qualified personnel such as licensed electricians or Certified Renewable Energy (RE) System installers.

The NEC (National Electric Code, ANSI/NFPA 70) for the United States and the CEC (Canadian Electrical Code, CSA 22.1) for Canada provide the standards for safely wiring residential and commercial installations. The NEC/CEC list the requirements for wire sizes, overcurrent protection, and installation methods and requirements.

Be aware that the MP/inverter system involves power from multiple sources (inverter, generator, utility, batteries, solar arrays, etc.) which make the wiring more hazardous and challenging.



WARNING: The AC neutral and DC negative are bonded to ground in this enclosure. If the AC or DC circuits are already bonded to ground elsewhere in your system, you must remove the DC and/or AC bonding inside this enclosure. Refer to Section 3.9 and 3.10 to remove the AC and/or DC ground bond connection.



WARNING: Ensure all sources of DC power (i.e., batteries, solar, wind, or hydro) and AC power (utility power or AC generator) are de-energized (i.e., breakers opened, fuses removed) before proceeding - to prevent accidental shock.

3.5.1 General Wiring Requirements

- The AC and DC wires into and out of the MP enclosure must be protected as required by code. This can be done by using jacketed wires or by feeding the wires through conduit.



Info: If using a Magnum inverter, and the AC wires are individual conductors (i.e., not jacketed), the strain reliefs on the inverter can be replaced with 3/4" grommets.

- Use proper clamps or other approved methods for securing the cable/conduit to the enclosure.
- The MP enclosure is specifically designed for both AC and DC wiring. However, where DC wiring must cross AC or vice-versa, try to make the wires at the crossing point 90° to one another.
- Use only copper wires with a minimum rating of 150V, 75°C if only 120V AC power is being used; or, with a minimum rating of 300V, 75°C if 120/240V AC power is being used.
- In a system where one conductor is grounded, the wire colors on the DC side and AC side are the same. The insulation on all grounded conductors (DC negative/AC neutral) must be white, gray, or any color except green if marked with white at each termination (marking only allowed on 6 AWG or larger conductors). The equipment grounding conductors must be bare (no insulation), or have green or green with yellow-striped insulation or identification. The hot-ungrounded conductor (DC positive/AC hot) is usually red or black.
- Terminals containing more than one conductor must be listed for multiple conductors.
- The connectors or terminals used on flexible, fine stranded conductors must be specifically marked or labeled for use with fine-stranded conductors.
- The MP enclosure includes wires (along with communication cables) with insulation rated for at least 300 volts, which allows 120/240V AC inverters to be installed. If installing a 120/240V AC inverter, the installer must also provide wires (both power and communication) with the insulation rated for at least 300 volts.

3.5.2 Disconnect Switch and Overcurrent Protection

For residential and commercial electrical systems, the NEC/CEC requires a disconnect switch and overcurrent protection for all ungrounded conductors on the AC side as well as the DC side. The MP enclosure provides both AC and DC circuit breakers that are used as the disconnect switch. These circuit breakers can also be used as the overcurrent protection device when the ampacity of the wire and its insulating material, voltage, and temperature rating are correctly sized to the circuit breakers in your MP enclosure. Refer to the appropriate installation section (AC Wiring or DC Wiring) to determine the minimum recommended wire size required.

3.0 Installation

3.5.3 Wire Routing

Before connecting any wires, determine all wire routes to and from the MP enclosure/inverter. Typical routing scenarios are:

- AC input wiring from the main AC panel or from a generator to the MP enclosure
- AC input and output from the MP enclosure to the inverter
- DC wiring from the batteries to the MP enclosure
- DC wiring from the inverter to the MP enclosure
- AC output wiring from the MP enclosure to the AC sub-panel or to dedicated circuits
- Battery Temperature Sensor cable from the inverter to the batteries
- Remote control and stacking cables to the inverter through the MP enclosure
- Ground wiring to and from the MP enclosure

3.5.4 Grounding

The MP/Inverter system is intended to be installed as part of a permanently grounded electrical system per the National Electrical Code (NEC) ANSI/NFPA 70 in the United States, Canadian Electrical Code (CEC) CSA 22.1 in Canada, as well as all state and local code requirements. Information and diagrams on the AC and DC ground circuits between the inverter and the MP enclosure are provided in the AC and DC wiring sections.

Information on grounding the entire MP/inverter system to earth ground is provided in Section 3-11 and the actual system ground wiring configuration must be determined by the installer.

3.5.5 Torque Requirements

Follow the specific torque recommendations in the tables below to ensure your fasteners are tightened sufficiently. To ensure your connections are correct, you should use an accurate, quality torque wrench.



CAUTION: It is highly recommended to go back over all fasteners/connections and re-torque after 5 days, and every 6 months thereafter.



CAUTION: AC and DC power/wire connections that are under-torqued could become loose and result in a fire hazard. On the other hand, over-tightening a bolt could cause the fastener to be snapped off.

Table 3-1, Torque Values for Dual Hole Busbars

Torque values for the dual hole busbars (i.e., AC, DC, AC NEUTRAL and GROUND busbars) - these busbars have different torque values for the small and large set-screws.

Wire Size	Busbar Set-Screw Size Torque Values	
	10-32 (Small Set-Screw)	5/16-24 (Large Set-Screw)
#14 to #10 AWG	15 in. lbs. (1.7 N-m)	35 in. lbs. (4.0 N-m)
#8 AWG	20 in. lbs. (2.3 N-m)	40 in. lbs. (4.5 N-m)
#6 AWG	25 in. lbs. (2.8 N-m)	45 in. lbs. (5.1 N-m)
#4 AWG	Not Applicable	45 in. lbs. (5.1 N-m)
#3 to #1/0 AWG	Not Applicable	50 in. lbs. (5.6 N-m)

Table 3-2, Torque Values for 3/8-16 Bolts¹

10 to 12 ft. lbs.
(13.6 to 16.3 N-m)

Table 3-3, Torque Values for Terminal Screws on AC Input Breakers

Single-pole 60A breakers	45 in. lbs. (5.1 N-m)
Double-pole 30A breakers	45 in. lbs. (5.1 N-m)

Note 1 - The 3/8-16 bolts are used on the DC Shunt Busbars and DC Disconnect Breakers.

3.6 AC Wiring

This section provides information on the AC wiring inside the MP enclosure. It covers all AC wiring to/from the inverter, from the incoming external AC source, and to the outgoing external AC distribution panel (i.e., inverter sub-panel).

3.6.1 AC Wiring Guidelines



CAUTION: Before installing any AC wiring, review the safety information at the beginning of this manual and below to ensure a safe and long-lived system:

- Read all instructions and cautionary markings located at the beginning of this manual and in the Pre-installation section before installing the inverter and batteries.
- AC wiring must be no less than #10 AWG (5.3 mm²) gauge copper wire and be approved for residential wiring.
- DO NOT connect the Magnum inverter's output to an AC power source. This could cause severe damage to the inverter and is not covered under warranty.



WARNING: To reduce the risk of fire, do not connect a 120V AC only inverter to both busbars in an AC load center (circuit breaker panel) having multi-wire branch circuits connected. Every circuit connected to a 120V AC panel must have its own neutral; otherwise, currents on shared neutrals will add rather than subtract, overloading the neutral conductor.

3.6.2 AC Connections

To view the AC connection points inside the MP enclosure, review Figure 3-12 for MPSL-30D and MPSH-30D models, Figure 3-13 for MPSL-60S models, or Figure 3-13 for MPDH-30D models.

3.6.2.1 AC Input/Output Connections

The MP enclosure provides busbars that allow the AC wiring (both inverter and external) to be easily and permanently wired. Each busbar has dual set-screw compression terminals allowing #14 to #1/0 AWG wires using the larger set-screws and #14 to #6 AWG wires using the smaller set-screws. These busbars use slotted head set-screws and should be torqued according to Table 3-1. The lower section of the MP enclosure provides the external AC input and output busbars. The external AC input busbars are labeled AC HOT 1 IN, AC HOT 2 IN, AC NEUTRAL, and GROUND. These busbars are used to wire a service/distribution panel (AC main panel) which allows the incoming utility/AC generator input to be connected to the inverter's input breakers. The external AC output busbars are labeled AC HOT 1 OUT, AC HOT 2 OUT, AC NEUTRAL, and GROUND. These busbars allow a dedicated inverter panel (AC sub-panel) to be wired between the inverter's output and the AC loads.

The upper section of the MP enclosure provides the inverter's AC output busbars. The inverter busbars are labeled INV HOT 1 OUT, INV HOT 2 OUT, AC NEUTRAL, and GROUND. These busbars combine all the inverter outputs together when stacked for increased power capability.



Info: The busbars labeled AC NEUTRAL in the MP enclosure ARE connected together. You do not need to provide both an inverter input and output neutral connection when using the Magnum MS-PAE Series inverter because the input and output neutrals are connected together. However, using any other Magnum inverter, the input and output neutrals are not connected, so you must connect to the inverter's input and output neutral terminals when wiring the neutral wires.



Info: The busbars labeled GROUND in the MP enclosure ARE connected together. You do not need to provide both an inverter AC input and output ground connection.



CAUTION: A neutral to ground connection is provided in the MP enclosure. If a neutral to ground connection is provided elsewhere in the AC system, the connection inside the MP enclosure must be disconnected. See Section 3.9 for information to disconnect this neutral to ground connection.

3.0 Installation

3.6.3 Inverter AC Wires and Overcurrent Protection

The inverter's AC input and output wiring must be sized per the local electrical safety code requirements to ensure the wires' ability to safely handle the inverter's maximum load current. AC wiring is required to be protected from short circuits and overloads by an overcurrent protection device, and have a means to disconnect the AC circuits.

The wires provided in the MP AC Wire Kit (as listed in Table 3-4 for your particular MP enclosure model) are sized to handle the inverter's maximum load current. The MP enclosure provides AC circuit breakers for the inverter's AC input. These breakers are branch circuit rated and can be used as the overcurrent protection and the AC disconnect device as long as the wires in the MP AC Wire Kit for your particular MP enclosure (or wires with at least the same rating) are used. If you are using other wire/circuit breaker sizes, refer to the appropriate electrical codes for proper sizing requirements.

When parallel stacking, a Magnum MS4024PAE or MS4448PAE inverter will be used. The full AC continuous pass-thru capacity of these inverters is 30 amps for each AC leg (AC HOT 1 or AC HOT 2), and requires a maximum 30 amp breaker on each AC input to protect the inverter's internal pass-thru relay. This correlates with the MPSL-30D, MPSH-30D, or MPDH-30D models, which include a double-pole 30 amp input inverter breaker and requires a minimum wire size of #10 AWG¹ in conduit.

When series stacking, the Magnum MS4024 inverter will be used. The AC HOT 1 and AC HOT 2 in this inverter may be combined to obtain a 60 amps pass-thru capability. When tying the AC HOT 1 and HOT 2 together for a 60 amp continuous pass-thru capability, the AC input to the inverter requires a 60 amp breaker. This correlates with the MPSL-60S models, which include a single 60 amp breaker for each inverter and requires a minimum wire size of #6 AWG¹ in conduit.



Info: Additional space is provided in the MP enclosure to allow an AC breaker to be installed for each additional inverter installed. These breakers are included with the MPX Extension Kit along with the required hardware and wires for installation.

Table 3-4, MP AC Wire Kits

AC Wire Reference	Separate Wires into:	A80-MPAC-30D-SH (for MPSL-30D, MPSH-30D and MPDH-30D/AC Side)	A80-MPAC-60S-SH (for MPSL-60S)	A80-MPAC-30D-LG (for MPDH-30D/DC Side)
INV HOT 1 IN	AC INPUT Side (3 wire bundle)	#10 AWG Black (24") ²	#6 AWG Black (24") ²	#10 AWG Black (33") ²
INV HOT 2 IN		#10 AWG Red (24") ²	NA (provided with MPX wire kit)	#10 AWG Red (33") ²
INV NEUTRAL IN		NA (MS-PAE neutrals in common)	#6 AWG White (24")	NA (MS-PAE neutrals in common)
INV AC GROUND		#10 AWG Green (24")	#10 AWG Green (24")	#10 AWG Green (33")
INV HOT 1 OUT	AC OUTPUT Side (2-3 wire bundle)	#10 AWG Black w/Stripe (24") ²	#6 AWG Black w/Stripe (24") ²	#10 AWG Black w/Stripe (33")
INV HOT 2 OUT		#10 AWG Red w/Stripe (24") ²	NA (provided with MPX wire kit)	#10 AWG Red w/Stripe (33") ²
INV NEUTRAL OUT		#10 AWG White (24")	#6 AWG White w/Stripe (24")	#10 AWG White (33")

Note 1 - This wire must be copper with a minimum rating of 300V, 75°C at an ambient temperature of 30°C.

Note 2 - This wire is longer than required to allow at least 7" to be cut and used for connecting to the bottom of the inverter AC input breakers.

3.6.4 External AC Wires and Overcurrent Protection

The MP enclosure also provides a full system AC branch-rated circuit breaker – as part of the AC bypass switch. This AC breaker can be used as the overcurrent protection and disconnect for the total current that the MP enclosure system provides to the inverter's AC electrical sub-panel. This is true as long as the wires routed from the MP enclosure to the inverter's AC electrical sub-panel are no smaller than those listed in Table 3-5 for your particular MP enclosure model. If you are using other circuit breakers or wire sizes, refer to the appropriate electrical codes for proper sizing requirements.

Table 3-5, Minimum AC Wire Size for AC Output Breaker

MP Enclosure Model	AC Output Breaker (part of Bypass Assembly)	Conductor Temperature Rating	
		75°C (167°F)	90°C (194°F)
MPSL-30D	60 amps	#6 AWG (65 amps)	#6 AWG (75 amps)
MPSL-60S	60 amps	#6 AWG (65 amps)	#6 AWG (75 amps)
MPSH-30D	125 Amps	#1 AWG (130 amps)	#2 AWG (130 amps)
MPDH-30D	125 Amps	#1 AWG (130 amps)	#2 AWG (130 amps)

Note - The recommended minimum wire sizes listed above are based on using copper wire with a minimum rating of 300V and at an ambient temperature of 30°C (86°F). If more than three cables are used together, a cable fill factor de-rating may be needed. The insulation of the wire must be rated for the environmental condition in which it will be used (i.e., for residential use, THHN is commonly used).

Note - Refer to Section 3.11 to assist in determining the appropriate ground conductors for the AC system based on the conductors used to/from the MP enclosure.

3.6.5 AC Conductor Wiring

The following steps are basic guidelines for installing and connecting the AC wiring to and from the inverter (refer to Figures 3-17 thru 3-19 depending on your particular model). Also see Section 4.0 for the specific wiring diagrams for your particular MP enclosure.



WARNING: To prevent electrical shock, make sure all AC power (inverter, generator, or utility) is off before making any AC connections inside the MP enclosure.

Wiring External AC Source and AC Load Panel

1. Route appropriate wires/cables from a dedicated breaker in the AC electrical main panel through one of the MP enclosure's knockouts to the AC input busbars (INPUT FROM GEN/GRID).
2. Route appropriate wires/cables (determined from Table 3-4) from the AC input busbars (OUTPUT TO INVERTER LOADS) through another MP enclosure knockout to the AC electrical sub-panel.



CAUTION: When connecting external AC wires to the MP enclosure, the proper phasing sequence (i.e., LEG 1/HOT 1 = Black, and LEG 2/Hot 2 = Red) should be maintained throughout the installation process. Refer to the system installation drawings in Section 4.0 showing the proper phasing convention. In the event the power conductors from the external AC source (i.e., generator or grid) or the wiring into or out of the inverters are not phased correctly, damage may occur.

Wiring Inverter AC Input/Output

1. Route the inverter's AC input wires (previously connected in Section 3.3.3) to the top of the inverter AC input breaker(s) inside the MP enclosure (INPUT TO INVERTER).
2. Route the inverter's AC output wires (previously connected in Section 3.3.3) to the inverter AC output busbars inside the MP enclosure (OUTPUT FROM INVERTER).

AC Wiring Inspection

After verifying all AC connections are correct, and all AC terminal screws are torqued correctly (refer to Tables 3-1 to 3-3), replace the covers on the main electrical panel/sub-panel.

AC Connections (MPSL-30D and MPSH-30D Models)

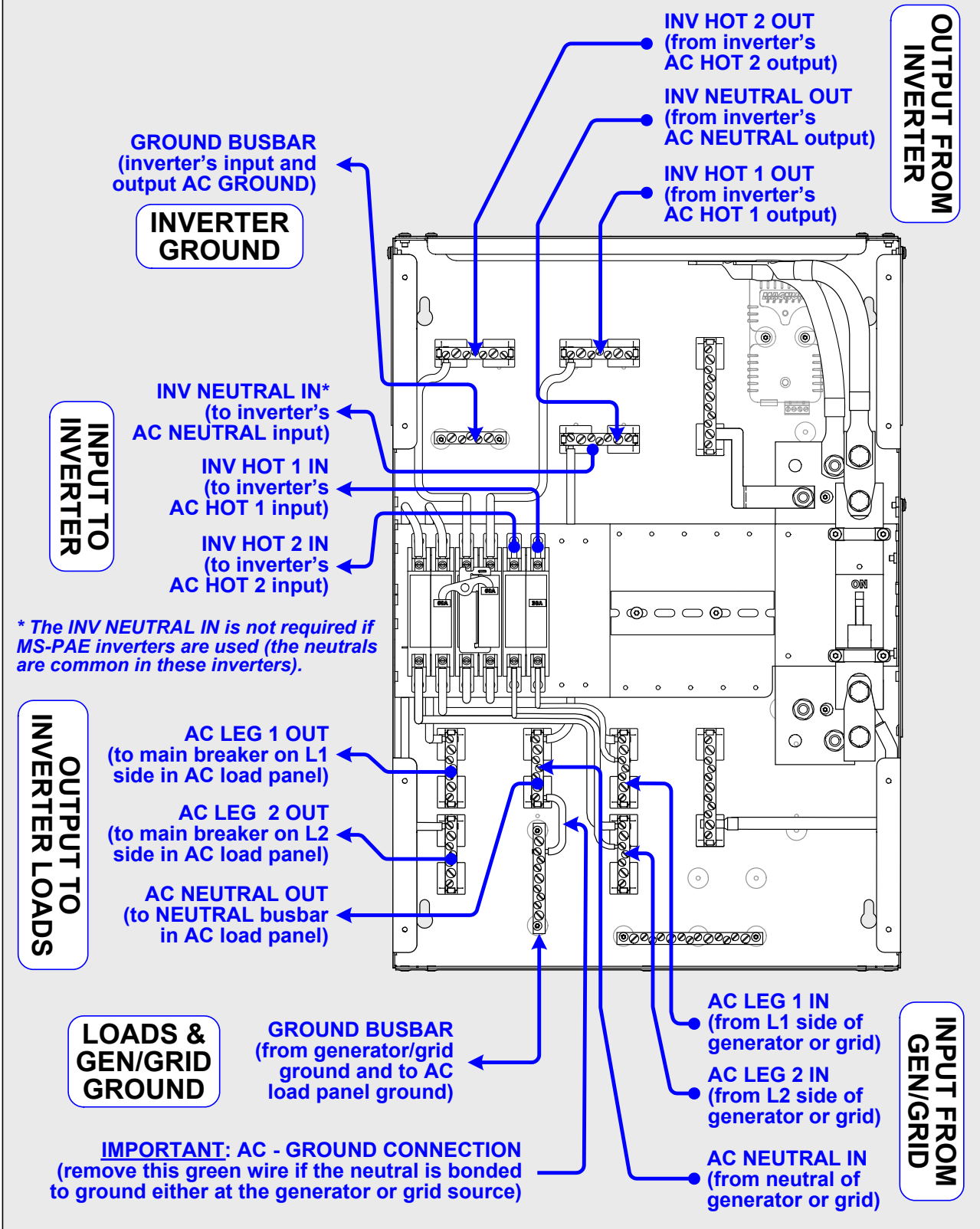

Figure 3-17, MPSL-30D and MPSH-30D AC Wiring Connections

AC Connections (MPSL-60S Models)

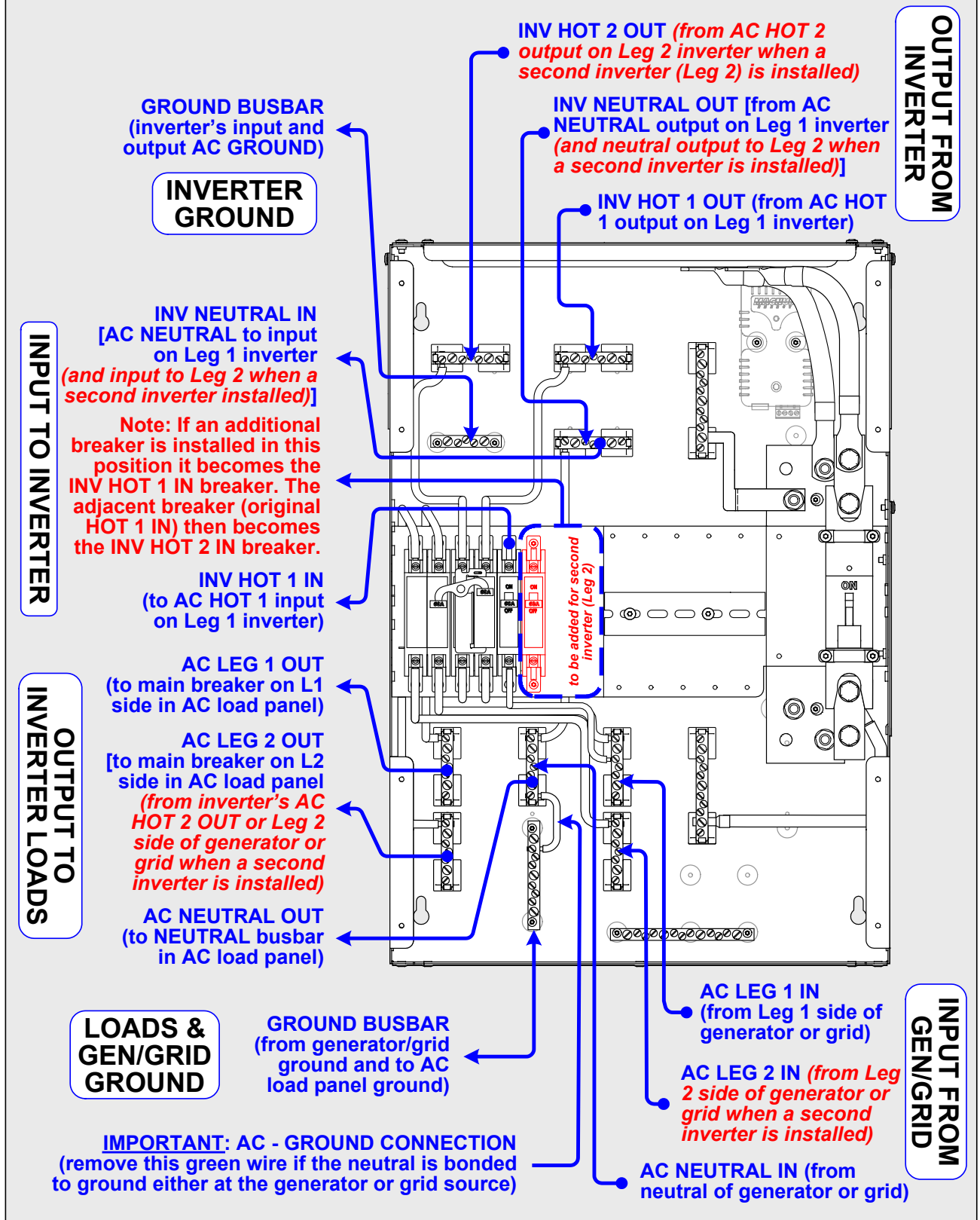

Figure 3-18, MPSL-60S AC Wiring Connections

3.0 Installation

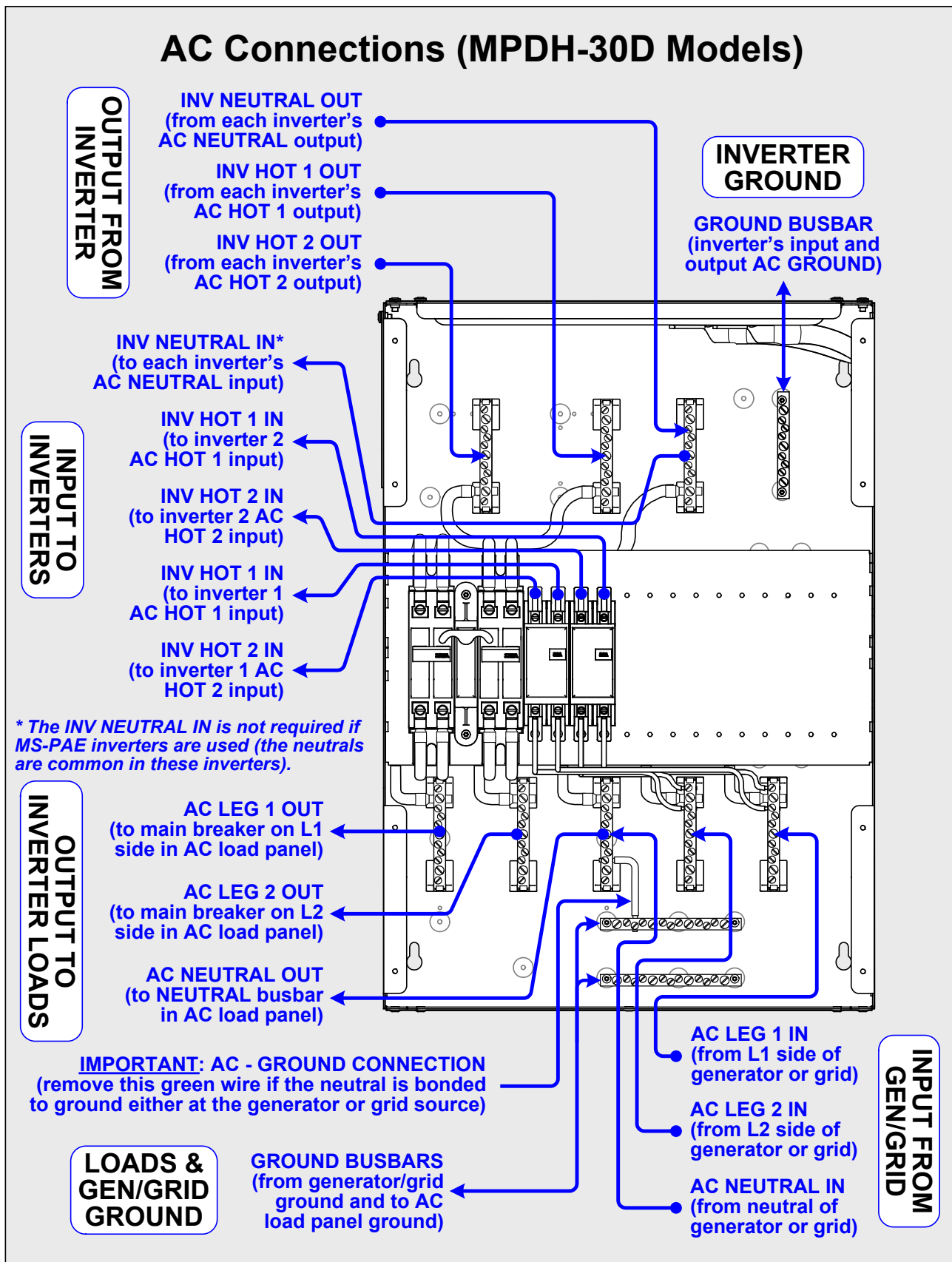

Figure 3-19, MPDH-30D AC Wiring Connections

3.7 DC Wiring

This section describes the DC wiring from inside the MP enclosure to the inverter, and from the MP enclosure to the battery bank.



Info: If installing optional DC breakers, see Section A6 in Appendix A.

3.7.1 DC Wiring Guidelines



WARNING: During normal operation the terminals, busbars, and electrical components inside the MP enclosure may be energized - DO NOT TOUCH. Disconnect all power sources before removing the cover.



WARNING: Even though the DC voltage/battery bank is considered “low voltage”, significant hazards are present because of the high current available, particularly if the battery system has a short circuit.



CAUTION: Before wiring the DC cables, review the safety information at the beginning of this manual and the following information to ensure a safe and long-lived system.



CAUTION: If you are using fine-stranded DC cables, the crimp or compression lug used must be specifically marked or labeled for use with fine-stranded conductors. Failure to use the proper terminal may cause the connection to heat-up, and it may eventually fail or become a fire hazard.



CAUTION: DO NOT connect the battery cables to the inverter until all wiring is complete, and the correct DC voltage and polarity have been verified.

- When the inverter is installed in a Photovoltaic System, the NEC requires that the DC circuit conductors and overcurrent devices to the inverter be sized to carry not less than 125% of the inverter's maximum current rating.
- The DC positive and negative cables from the battery bank should be tied together with wire ties or electrical tape approximately every six inches. This helps improve the surge capability and reduces the effects of inductance, which improves the inverter waveform and reduces the wear of the inverter's filter capacitors.
- Crimped and sealed copper compression lugs with a 3/8" hole should be used to connect the battery cables to the DC Disconnect Breaker and the DC Shunt busbar inside the MP enclosure.
- The battery bank voltage MUST match the DC voltage required by the inverter (i.e., 24-volt battery bank for a 24-volt inverter), or the inverter may be damaged.
- The DC cables must be of a type listed for use in conduit (i.e., THHN, RHW or THW).
- To ensure the maximum performance from the inverter, all connections from the battery bank to the inverter through the MP enclosure should be minimized, the exception is the DC circuit breaker in the positive line and the DC shunt in the negative line. Any other additional connection will contribute to additional voltage drops and may loosen during use.
- All wiring to the inverter and battery terminals should be checked periodically (once a month) for proper tightness. Refer to the torque requirements in Tables 3-1 to 3-3.
- After making the battery connections and ensuring they are properly tightened, cover the outside of the connection with petroleum jelly or an antioxidant grease/spray. Do not put jelly/anti-corrosion grease between the terminal and the battery cable.
- Ensure the color code for the DC cables/wires are correct: RED for positive (+); WHITE for negative (-); and GREEN, GREEN with YELLOW stripe, or bare for DC equipment grounds.

3.0 Installation

3.7.2 Inverter DC Overcurrent Protection and DC Disconnect

In a battery-based inverter system, the NEC/CEC assumes that each ungrounded conductor is connected to some source that supplies currents in excess of the ampacity rating of the conductor and could potentially damage that conductor under fault conditions. Because of this, the NEC/CEC requires that all ungrounded conductors in the inverter's DC system be protected by an overcurrent device, this can be either a circuit breaker or fuse. These breakers or fuses are not intended to protect equipment from damage, but protect the conductor/wire from overheating which may potentially cause a fire. This means the overcurrent device is required to open before the conductor reaches its maximum current carrying capability, thereby preventing a fire.

The NEC also requires the inverter system to have a DC disconnect switch to allow service providers to isolate the inverter from the battery. The disconnect must be either a DC rated circuit breaker or switch.

The MP enclosure is provided with a 250 amp UL listed, high interruption capacity, magnetic-hydraulic, DC rated circuit breaker. These breakers are designed to interrupt the tremendous amount of current a battery can deliver when short-circuited. They are also specifically designed to have a long enough time delay to prevent the breaker from tripping, as the inverter requires high current levels when powering heavy loads.

If the battery cables to the inverter are no longer than five feet and the wire size is a minimum #4/0 AWG¹, the circuit breakers in the MP enclosure can provide the inverter system with both the DC overcurrent protection device and a safety disconnect switch.

If your battery to inverter cable length is greater than five feet, the DC wire size will need to be increased. Longer distances cause an increase in resistance, which affects the performance of the inverter.

If your battery to inverter cable size is smaller than the recommended minimum DC wire size (#4/0 AWG¹), you must install a fuse/circuit breaker close to the battery bank that is compatible with this smaller cable to protect against a potential fire.



CAUTION: In a low voltage/high amperage system, it is important to use the correct DC wire to achieve maximum efficiency and to reduce fire hazards associated with overheating. Always keep your wire runs as short as practical to help prevent low voltage shutdowns.



Info: Circuit breakers or fuses that are used on the DC side must be UL listed and DC rated for the application.

3.8.2.1 Optional DC Breakers/Disconnects

When installing multiple inverters, the MP enclosure provides the space to add a 250 amp breaker, for each additional inverter. These breakers — along with all the wires and hardware — are provided with the MPX Series Extension Kit.

All MP enclosures (except for the MPSH-30D) provide space to field install additional DC breakers for use as DC input/output breakers for PV, charge controllers, or DC loads. See Section A6 for more information.

Note 1 - Wire must be copper with a minimum rating of 300V, 75°C at an ambient temperature of 30°C.

3.7.3 DC Hardware Connections

Do not put anything between the DC cable lug and the DC terminals (i.e., on the Inverter DC Disconnect, DC shunt busbars, batteries, or inverter terminals). Ensure the hardware used to hold these connections is stacked correctly. Incorrectly installed hardware causes a high resistance connection which could lead to poor inverter performance, and may melt the cable and terminal connections. Follow Figure 3-20 to connect the DC cables and stack the hardware correctly.



Info: After making the battery connections and ensuring they are properly torqued, cover the outside of the connection with petroleum jelly or an antioxidant grease/spray. Do not put jelly/anti-corrosion grease between the terminal and the battery cable.

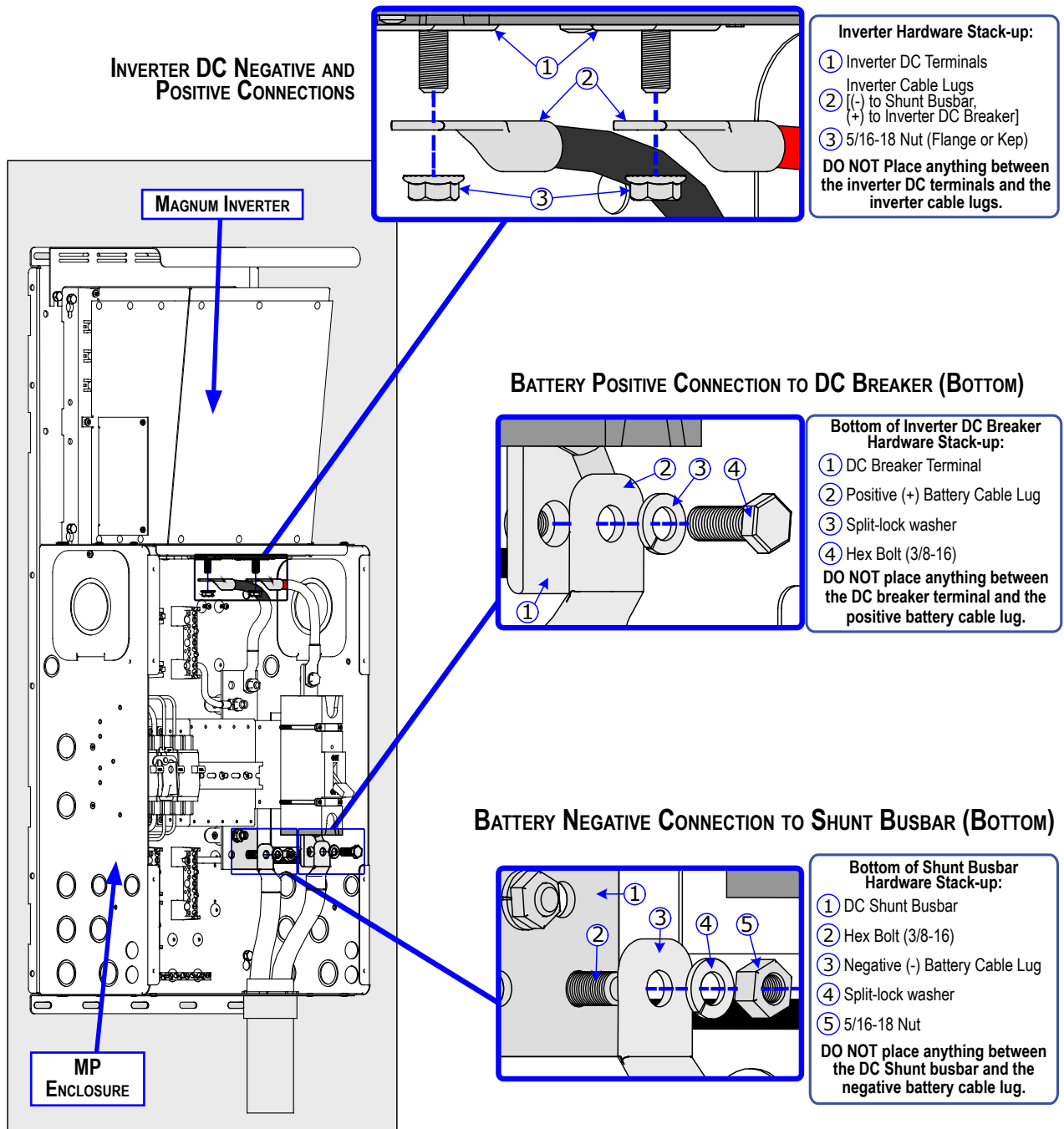

Figure 3-20, DC Hardware Connections

3.0 Installation

3.7.4 Wiring the Battery Bank

Depending upon the voltage of the batteries used in the installation (2V, 6V, or 12V DC), the batteries must be wired in series, parallel, or series-parallel to provide the correct voltage. The interconnecting DC cables should be the same size and rating as those used between the battery bank and the inverter.

Place the batteries as close as practical to the MP enclosure/inverter system, preferably in an insulated and ventilated enclosure. Allow adequate space above the batteries to access the terminals and vent caps (as applicable). Also allow at least 1" of space between the batteries to provide good air flow. DO NOT mount the batteries directly under the MP enclosure/inverter system.



Info: To ensure the best performance from the MP enclosure/inverter system, batteries should be of the same size, type, rating, and age. Do not use old or untested batteries.

3.7.4.1 Wiring the MP enclosure to the Battery Bank/Inverter



WARNING: Ensure that all AC and DC breakers are switched OFF before connecting or disconnecting the battery cables, and that all sources of power (both AC and DC) are disconnected from the inverter.



WARNING: Lethal currents will be present if the positive and negative cables attached to the battery bank touch each other. During the installation and wiring process, ensure the cable ends are insulated or covered to prevent touching/shorting the cables.



CAUTION: DO NOT connect the DC wires to the battery bank until: 1) all DC, AC, and accessory wiring are completed, 2) the correct DC and AC overcurrent protection have been installed and, 3) the correct DC voltage and polarity have been verified.



CAUTION: The Magnum inverter is NOT reverse polarity protected. Before making the final DC connection from the batteries to the inverter, use a voltmeter to verify the correct battery voltage and polarity. If the positive (+) terminal of the battery is mistakenly connected to the negative (-) terminal of the inverter and vice versa, the inverter will be damaged and will not be covered under warranty. Color code the cables to avoid polarity confusion.

The following steps are basic guidelines for installing and connecting the DC wiring into and out of the MP enclosure (refer to Figures 3-21 thru 3-23 depending on your particular model). Also see Section 4.0 for the specific wiring diagrams for your particular MP enclosure.

1. Route the DC cables from inside the MP enclosure and connect them to the inverter's DC terminals; the negative cable (-) from the top side of the DC shunt busbar to the inverter's DC negative terminal, and the positive cable (+) from the top side of the DC breaker to the inverter's DC positive terminal. Be careful to observe proper polarity.
2. Route the DC cables from the battery bank — with the cables not connected to the battery — and connect them to the MP enclosure; negative (-) to the bottom side of the DC shunt busbar, positive (+) to the bottom side of the DC breaker. Be careful to observe proper polarity.
3. Ensure the DC wire connections (on the batteries, inverter, DC circuit breaker, and DC shunt busbars) are flush on the surface of the DC terminals and the hardware used to hold these connections are stacked correctly (see Figure 3-20); and then securely tighten these DC connections (refer to the torque requirements in Table 3-2).



CAUTION: Only after the entire installation is complete and all connections are verified should the DC circuit breaker be closed to provide power to the inverter.

4. Route an appropriately sized DC grounding wire (green or bare wire) from the inverter's DC equipment ground terminal and from the battery bank enclosure to the DC GROUND busbar in the MP enclosure. Refer to Section 3.11 for grounding information and sizing the DC ground wires.

3.7.5 DC Wiring Connection Points

Figures 3-21 thru 3-23 show the connection points for the DC wiring inside the MP enclosures.

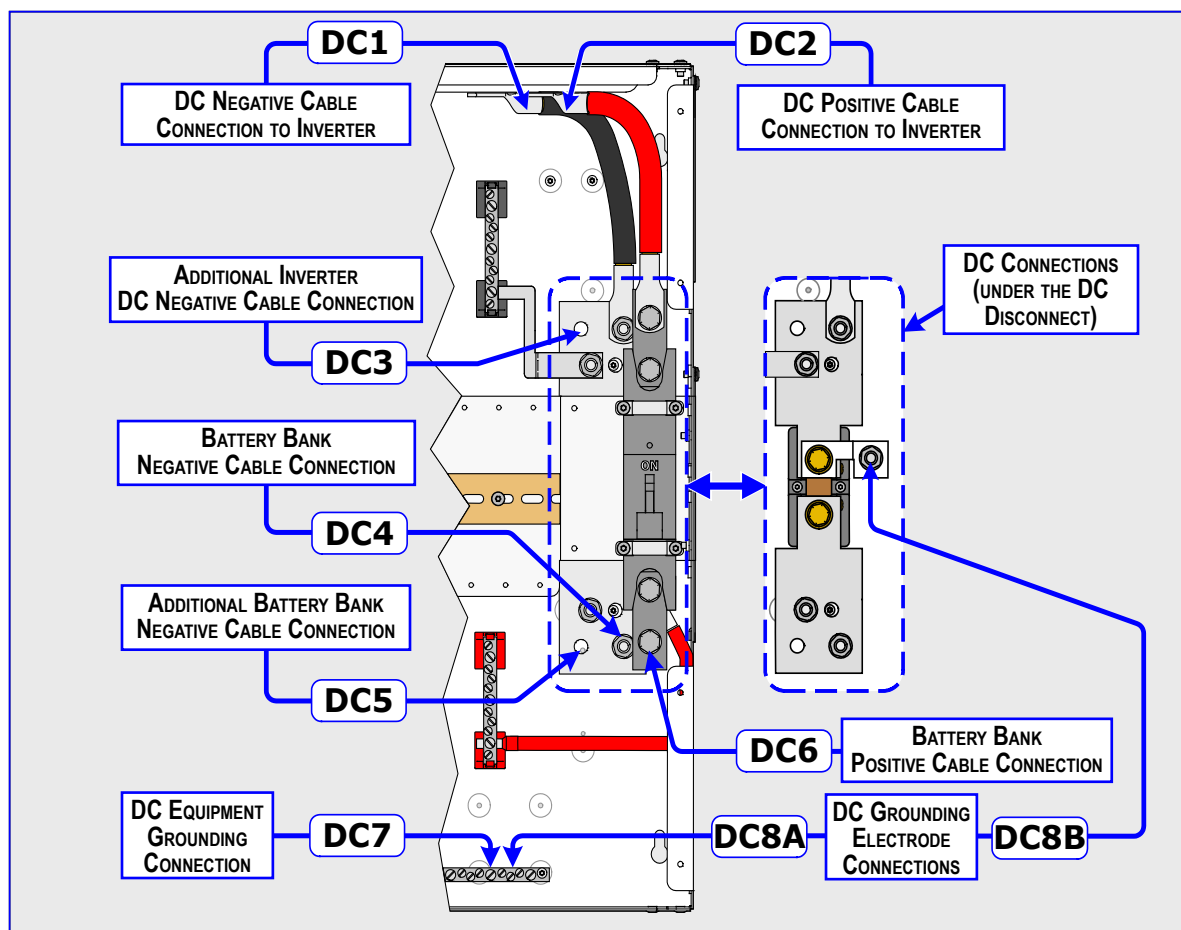

Figure 3-21, DC Wiring Connection Points for MP/SL Models

- DC1** **Inverter's DC Negative Cable Connection** - Cable connection to Magnum inverter's DC negative terminal. Electrically connected to the top of the DC shunt.
- DC2** **Inverter's DC Positive Cable Connection** - Cable connection to Magnum inverter's DC positive terminal. Electrically connected to the top of the inverter's DC disconnect.
- DC3** **Additional Inverter DC Negative Cable Connection** - Provided so that as more inverter's are added, cables can be added and connected to the inverter's DC negative terminals.
- DC4** **Battery Bank Negative Cable Connection** - DC Negative Busbar connection (bottom connection of DC shunt); connects cables to the battery bank's negative terminal.
- DC5** **Additional Battery Bank Negative Cable Connection** - Provided to connect additional cables to the battery bank's negative terminal when additional Magnum inverters are installed.
- DC6** **Battery Bank Positive Cable Connection** - Bottom of the inverter's DC disconnect breaker; connects the battery cable to the battery bank's positive terminal.
- DC7** **DC Equipment Grounding Connection** - This busbar is used as the common DC equipment ground point for all DC equipment connected in the MP/inverter system.
- DC8** **DC Grounding Electrode Connections** - These are the connection points for the MP/inverter system to the DC grounding electrode. Use DC8A for #6 to #1/0 AWG wires, and DC8B for greater than #1/0 AWG wires.

3.0 Installation

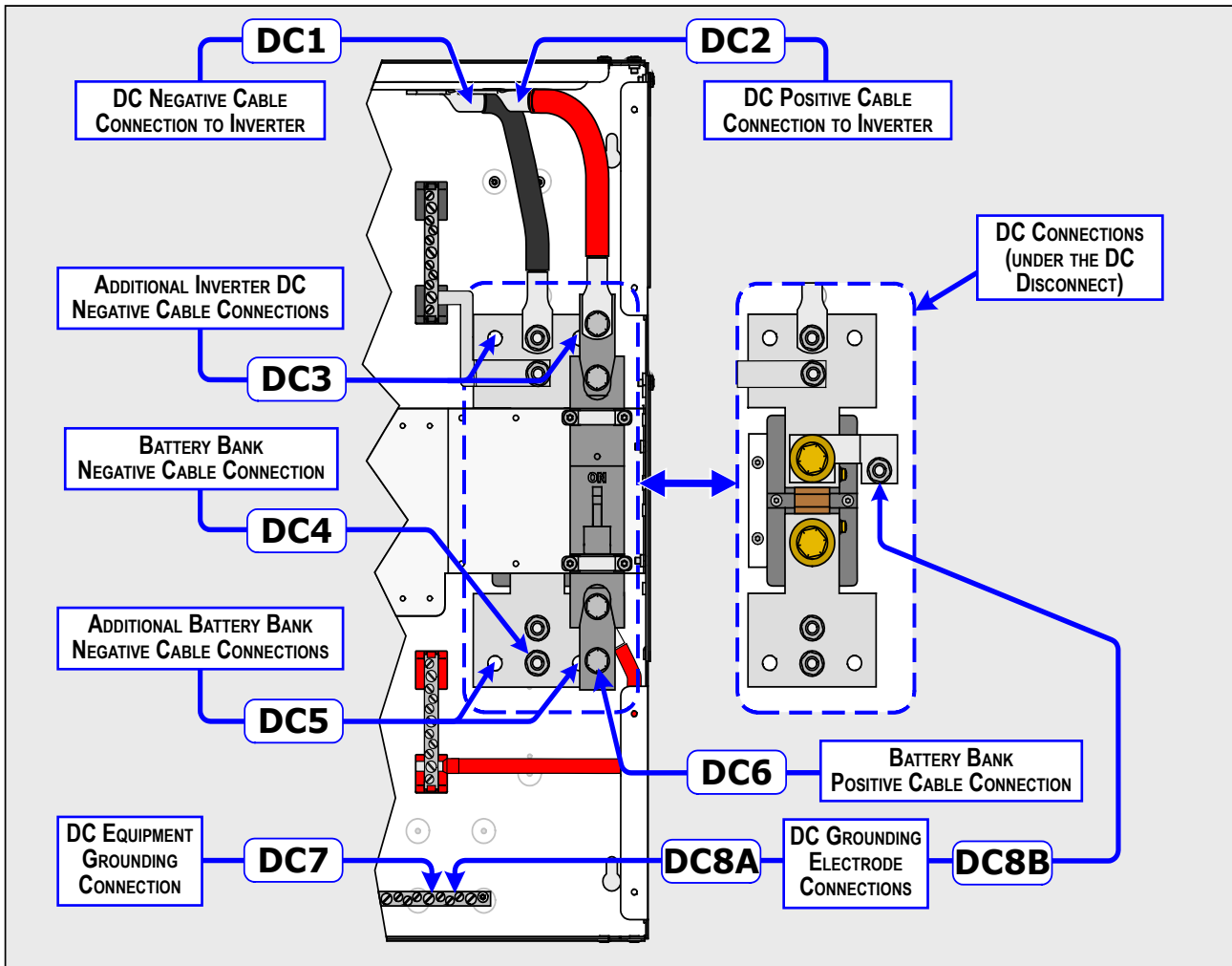

Figure 3-22, DC Wiring Connection Points for MPSH-30D

- DC1** **Inverter's DC Negative Cable Connection** - Cable connection to Magnum inverter's DC negative terminal. Electrically connected to the top of the DC shunt.
- DC2** **Inverter's DC Positive Cable Connection** - Cable connection to Magnum inverter's DC positive terminal. Electrically connected to the top of the inverter's DC disconnect.
- DC3** **Additional Inverter DC Negative Cable Connections** - Provided so that as more inverters are added, cables can be added and connected to the inverter's DC negative terminals.
- DC4** **Battery Bank Negative Cable Connection** - DC Negative Busbar connection (bottom connection of DC shunt); connects cables to the battery bank's negative terminal.
- DC5** **Additional Battery Bank Negative Cable Connections** - Provided to connect additional cables to the battery bank's negative terminal when additional Magnum inverters are installed.
- DC6** **Battery Bank Positive Cable Connection** - Bottom of the inverter's DC disconnect breaker; connects the battery cable to the battery bank's positive terminal.
- DC7** **DC Equipment Grounding Connection** - This busbar is used as the common DC equipment ground point for all DC equipment connected in the MP/inverter system.
- DC8** **DC Grounding Electrode Connections** - These are the connection points for the MP/inverter system to the DC grounding electrode. Use DC8A for #6 to #1/0 AWG wires, and DC8B for greater than #1/0 AWG wires.

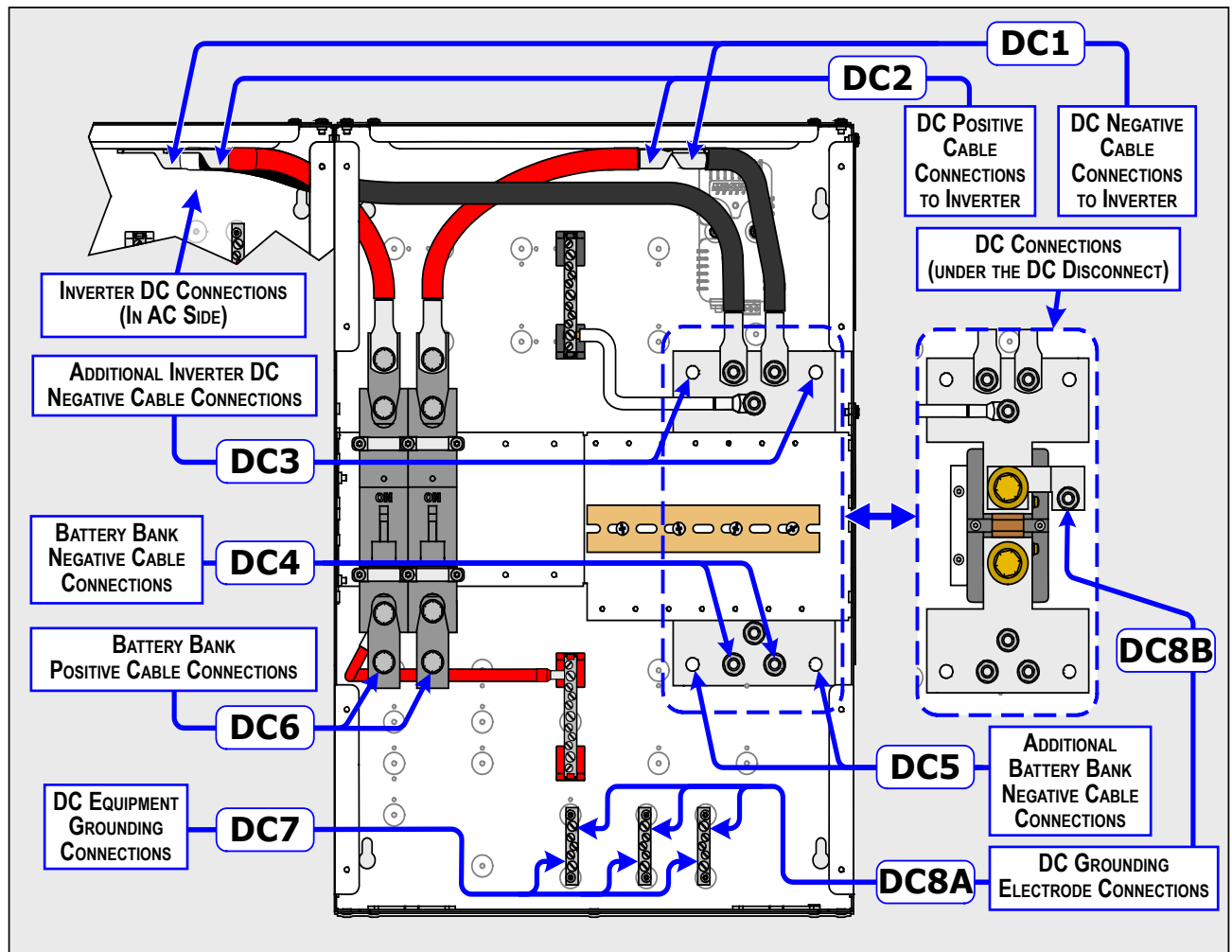

Figure 3-23, DC Wiring Connection Points for MPDH-30D (DC Side)

- DC1** **Inverter's DC Negative Cable Connections** - Cable connections to Magnum inverter's DC negative terminal. Electrically connected to the top of the DC shunt.
- DC2** **Inverter's DC Positive Cable Connections** - Cable connections to Magnum inverter's DC positive terminal. Electrically connected to the top of the inverter's DC disconnect.
- DC3** **Additional Inverter DC Negative Cable Connections** - Provided so that as more inverters are added, cables can be added and connected to the inverter's DC negative terminals.
- DC4** **Battery Bank Negative Cable Connections** - DC negative busbar connections (bottom connection of DC shunt); connect cables to the battery bank's negative terminal.
- DC5** **Additional Battery Bank Negative Cable Connections** - Provided to connect additional cables to the battery bank's negative terminal when additional Magnum inverters are installed.
- DC6** **Battery Bank Positive Cable Connections** - Bottom of the inverter's DC disconnect breaker; connect battery cables to the battery bank's positive terminal.
- DC7** **DC Equipment Grounding Connections** - These busbars are used as the common DC equipment ground point for all DC equipment connected in the MP/inverter system.
- DC8** **DC Grounding Electrode Connections** - These are the connection points for the MP/inverter system to the DC grounding electrode. Use DC8A for #6 to #1/0 AWG wires, and DC8B for greater than #1/0 AWG wires.

3.0 Installation

3.8 Wiring Accessories

The NEC/CEC requires the insulation of all conductors inside the MP enclosure to be rated for the highest voltage present. The MP enclosure is designed to work with inverters that provide 120/240V AC (i.e., MS-PAE Series), therefore, the voltage rating of the communications cables inside the MP enclosure must be rated for 300 volts or higher to be code compliant.

With the purchase of the MP enclosure, Magnum has included three six-foot, yellow communication cables with 300-volt rated insulation. These communications cables — shown below — are provided to make the connections between Magnum inverters and any accessories easier and code compliant. Figure 3-27 shows a basic drawing for connecting accessories into and out of the MP enclosure. Refer to Section 4.0 for specific communications wiring diagrams for your particular MP enclosure.



Info: These cables carry less than 30 volts and are thus considered a “limited energy circuit”, which is normally not required to be installed in conduit.

Figure 3-24 shows the ‘REMOTE’ cable. It allows a remote control — such as the ME-RC (Remote Control), ME-ARC (Advance Remote Control), or ME-RTR (Router) — to be connected to the inverter through the MP enclosure. This cable is a 6’ (1.83 m), 4-conductor, telephone-type cable with a RJ14 (m) connector and a blue REMOTE label on each end. One end of this cable is connected to the remote, and the other end is routed inside the MP enclosure and then connected to the inverter’s REMOTE port.



Figure 3-24, REMOTE Communication Cable (300V Rated)

Figure 3-25 shows the ‘NETWORK’ cable. It allows Magnum accessories — like the ME-AGS-N (Auto Generator Start - Network) or ME-BMK-NS (Battery Monitor - No Shunt) — to be connected to the inverter through the MP enclosure. This cable is a 6’ (1.83 m), 4-conductor, telephone-type with a RJ14 (m) connector and a green NETWORK label on each end. One end of this cable is connected to the accessory, and the other end is routed inside the MP enclosure and then connected to the inverter’s NETWORK port.



Figure 3-25, NETWORK Communication Cable (300V Rated)

Figure 3-26 shows the ‘EXTENSION’ cable. It allows the Magnum Battery Temperature Sensor (BTS) to be connected to the inverter through the MP enclosure. This is a 6’ (1.83 m), 4-conductor, telephone-type cable with a RJ14 (m) connector on one end and a RJ14 (f) plug on the opposite end. The female plug connects to the ME-BTS (Battery Temperature Sensor). After connecting to the ME-BTS, this extension cable is routed inside the MP enclosure and connects to the inverter’s BTS port.



Figure 3-26, Extension Cable (300V Rated)

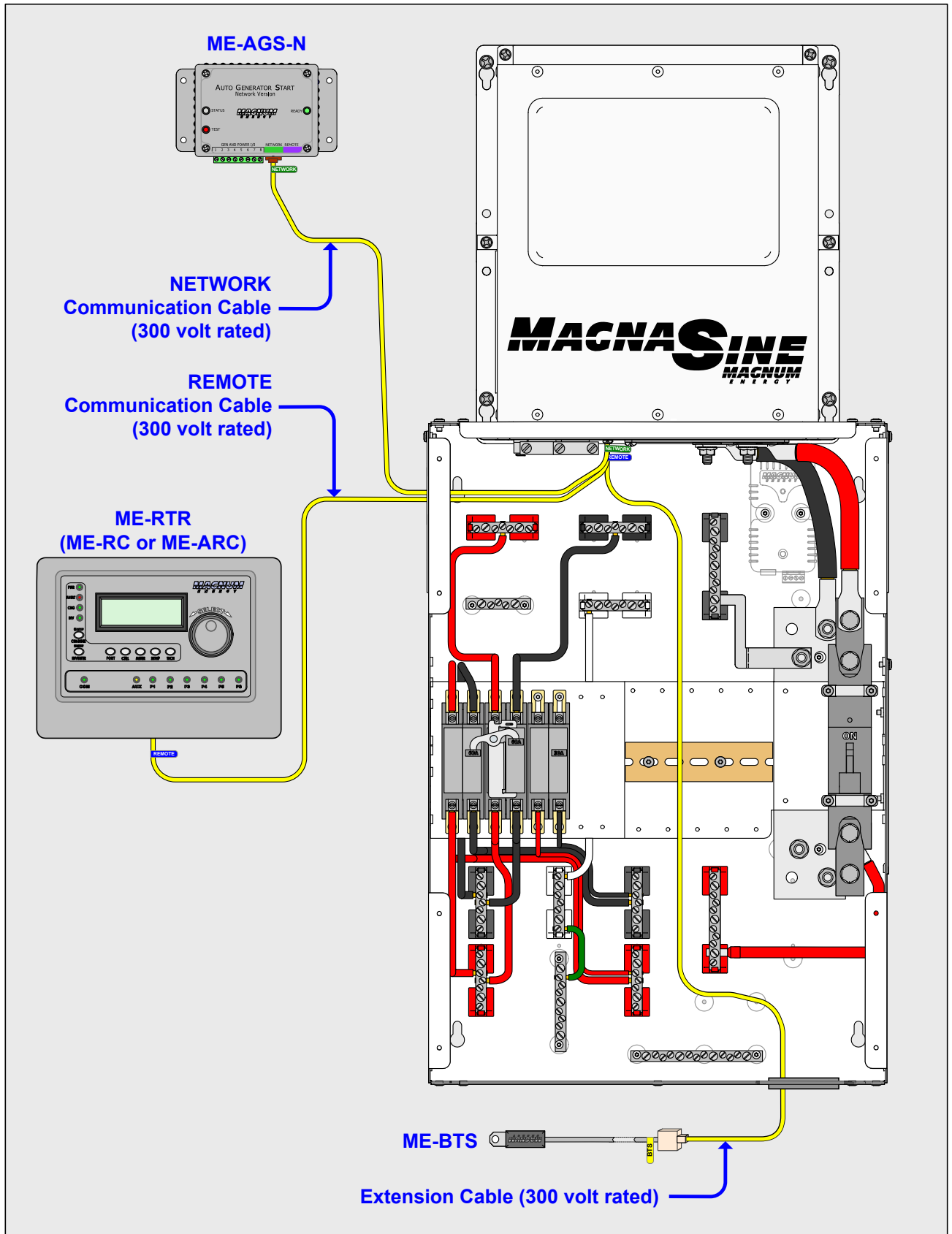

Figure 3-27, Accessory Wiring Using 300 Volt Communications Cables

3.0 Installation

3.9 Removing the NEUTRAL-GROUND Wire

The MP enclosure is shipped with the AC neutral connected to ground to provide the single point of ground for the AC system. The neutral to ground connection is done by connecting a green wire (Item 19, in Figures 2-7 and 2-8, Item 23 in Figure 2-9, or Item 13 in Figure 2-10a, depending on your MP model) between the AC NEUTRAL busbar and the GROUND busbar inside the MP enclosure.

In installations where the MP enclosure is powered from utility power or large permanently installed generator systems, the AC neutral to ground connection is normally provided inside the main AC electrical distribution panel. In these installations, the factory-installed NEUTRAL-GROUND wire in the MP enclosure must be removed to prevent multiple neutral to ground connections.

To remove the NEUTRAL-GROUND wire:

1. See Figure 3-28 below to help you locate the green wire with the NEUTRAL-GROUND CONNECTION label inside your MP enclosure.
2. Remove this green wire by loosening the screws on the AC NEUTRAL busbar and the GROUND busbar.
3. After this wire is removed, tighten the loose screws back into the busbars to prevent them from being lost.

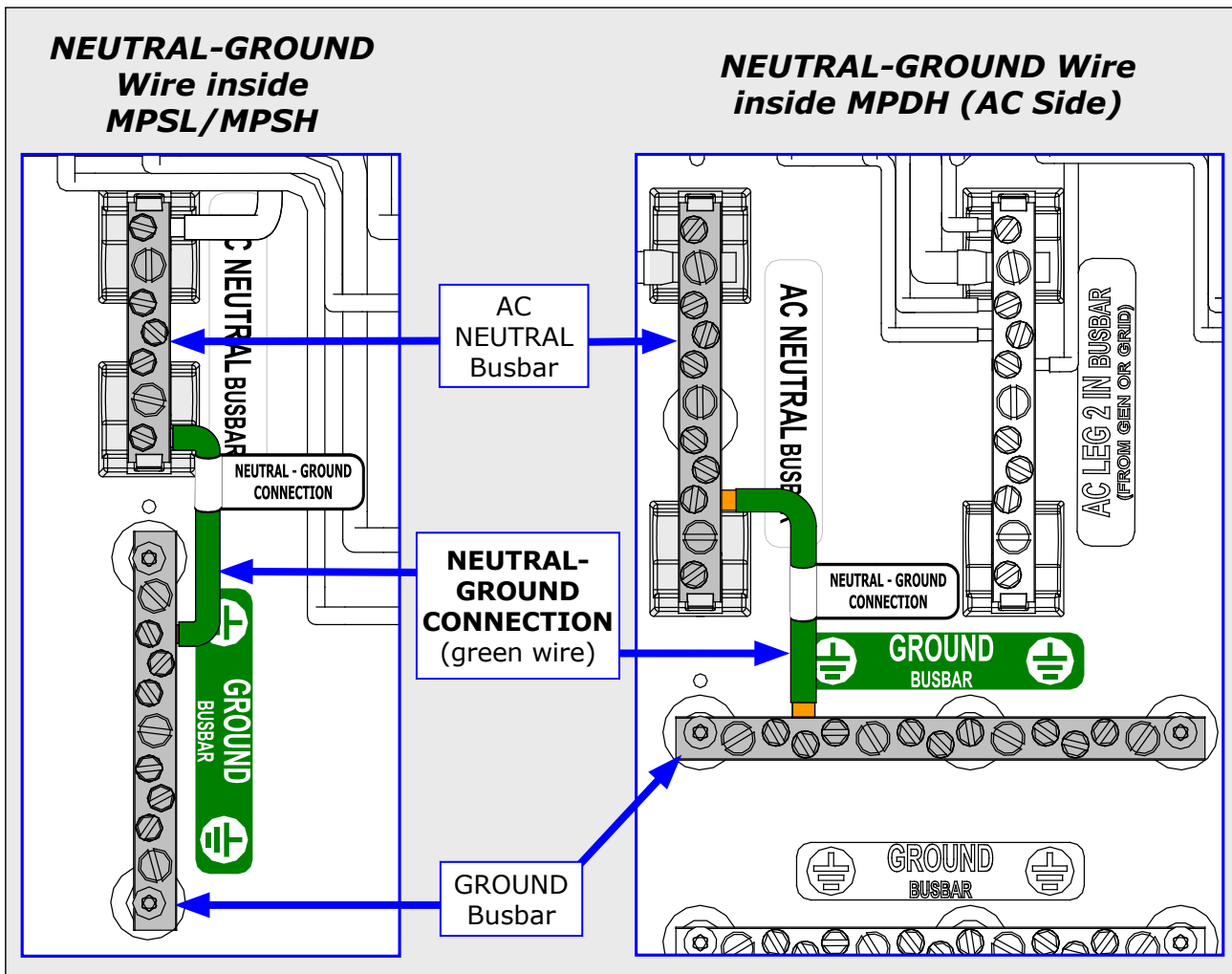
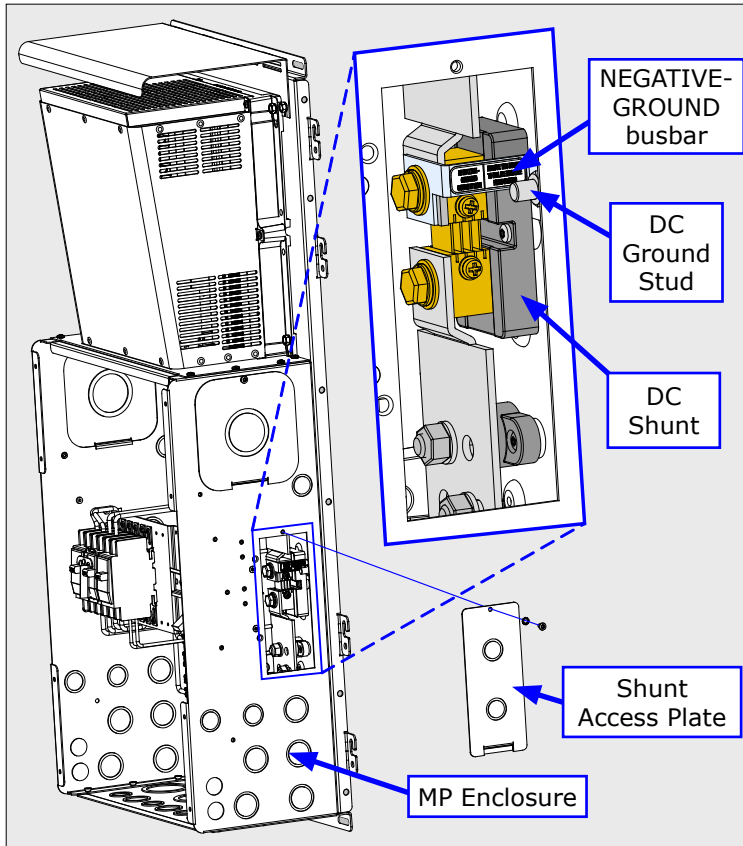

Figure 3-28, Removing the NEUTRAL-GROUND Wire

3.10 Removing the NEGATIVE-GROUND Busbar

The MP enclosure is shipped with the DC Negative connected to Ground to provide the single point of ground for the DC system. This negative to ground connection is done by connecting the DC Shunt (battery negative connection point) to the DC Ground Stud using the NEGATIVE-GROUND busbar. If a negative to ground connection is made elsewhere in the DC system — either at the battery terminal, inside a charge controller, or if you are installing a PV-Ground Fault Protection (PV-GFP) device — this busbar must be removed to prevent multiple negative to ground connections.



Follow the steps below to remove the NEGATIVE-GROUND busbar (refer to the diagram to the left to help locate the components discussed):

1. Remove the Shunt Access Plate on the right side of the MP enclosure. Locate the NEGATIVE-GROUND busbar (Item 27, in Figure 2-9; or Item 29, in Figures 2-7, 2-8 or 2-10b - depending on your MP model) attached to the DC Shunt.
2. Remove the 5/16" flange nut (1/2" wrench) holding the busbar to the DC Ground Stud and then remove the 3/8" brass bolt and washer (9/16" wrench) from the top terminal of the DC Shunt.
3. Remove the NEGATIVE-GROUND busbar.
4. Reattach the flange nut on the DC Ground Stud and the brass bolt/washer back onto the DC Shunt. Ensure the hardware on the top terminal of the DC Shunt is stacked/reattached and torqued correctly.

Note: The DC Shunt hardware is shown correctly stacked in the Step 4 diagram below.

Step 1, Remove Plate and Locate NEG-GND Busbar

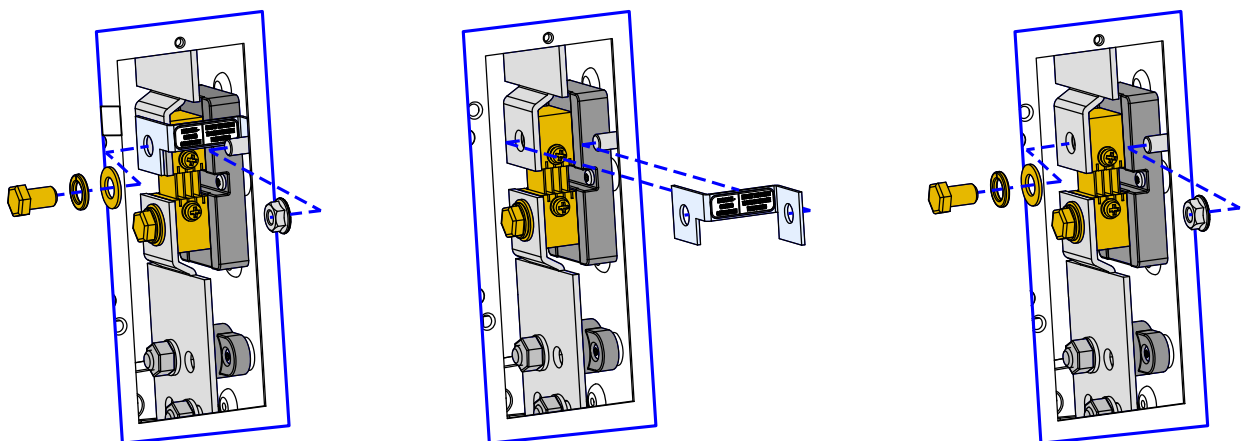

Step 2, Remove Shunt Hardware

Step 3, Remove the NEGATIVE-GROUND Busbar

Step 4, Reattach Shunt Hardware

Figure 3-29, Removing the NEGATIVE-GROUND Busbar

3.0 Installation

3.11 MP/Inverter System Grounding

The MP/inverter system uses both AC and DC electrical systems, therefore **each** electrical system is required to be properly connected to a permanent, common “ground” or “earth” reference. A MP/inverter system that is properly grounded limits the risk of electrical shock, reduces radio frequency noise, and minimizes excessive surge voltages induced by lightning. To understand how the conductors in the electrical circuit will be connected to the system ground, the following terms should be understood (also refer to Figure 3-30):

- **Grounded Conductor (GC):** The wire/cable in the electrical system that normally carries current (usually the AC neutral and/or the DC negative), and is intentionally connected or “bonded” to the ground system. This wire, or the ends of this wire, must be colored white or gray.
- **Equipment Grounding Conductor (EGC):** A wire/cable that does not normally carry current and is used to connect the exposed metal parts of equipment — that might be accidentally energized — to the grounding electrode system or to the grounded conductor. This wire, or the ends of this wire, must be green or green with a yellow stripe; or, this wire can be bare copper.
- **Grounding Electrode Conductor (GEC):** The wire/cable that does not normally carry current, and connects the grounded conductor and/or the equipment grounding conductor at the service equipment (i.e., equipment delivering the electrical energy) to the grounding electrode.
- **Grounding Electrode (GE):** A ground rod or conducting element that establishes an electrical connection to the earth or common ground reference.
- **System Bonding Jumper (SBJ):** The connection between the grounded circuit conductor in the electrical system and the equipment grounding conductor at a separately derived system.

There are two types of grounding — equipment grounding and system grounding.

The exposed metal parts of the equipment in the system usually don’t carry electricity. However, if the exposed metal becomes electrified by a live wire, a person touching this live part could complete the electrical circuit and receive a shock. Equipment grounding prevents shock by connecting all the exposed metal parts of equipment (via Equipment Grounding Conductors - EGC) together at a common ground point (Ground BusBar - **GBB**). This common ground point — installed in the service disconnect panel for each electrical system (AC and DC) — is then connected (via Grounding Electrode Conductor - GEC) to the common ground reference, such as a ground rod (Grounding Electrode - GE). This connection to earth is made at only one point in each electrical system; otherwise, parallel paths will exist for the currents to flow. These parallel current paths would represent a safety hazard and are not allowed in installations wired per the NEC/CEC.

System grounding takes one of the current-carrying conductors (Grounded Conductor - GC) and attaches it to the common ground point (Ground BusBar - GBB), usually by a System Bonding Jumper (SBJ) in each electrical service disconnect panel. On the AC side, that is the neutral conductor (**GC-AC**); on the DC side, it’s the negative conductor (**GC-DC**). The closer the grounding connection is to the source, the better the protection from high voltage surges due to lightning.

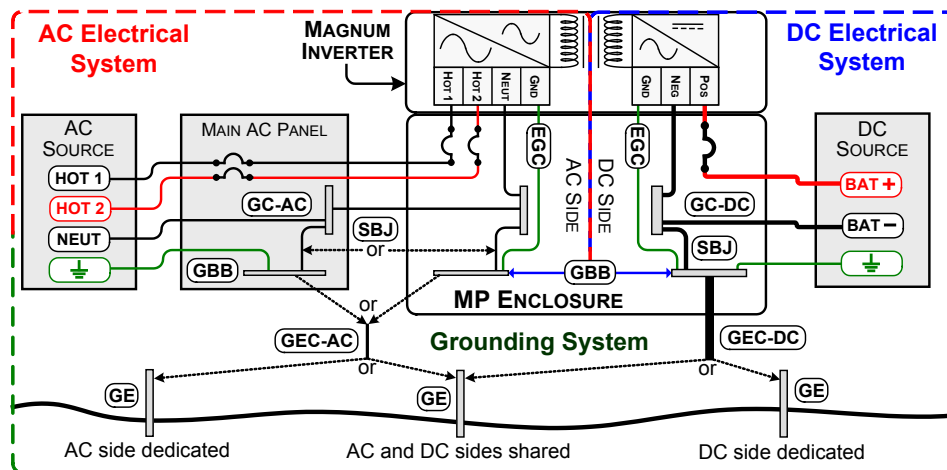

Figure 3-30, Grounding System for Inverter with MP Enclosure

3.11.1 Sizing the Grounding Electrode Conductors

AC Side - The size of the AC Grounding Electrode Conductor (GEC-AC) depends on the size of the largest ungrounded conductor feeding the AC load center. One #8 AWG (8.4 mm²) copper conductor will serve as an AC grounding electrode conductor for AC power conductors smaller than and including #2 AWG (33.6 mm²) copper. See Table 3-6 for additional values.

Table 3-6, AC Grounding Electrode Conductor Sizing

Size of Largest Ungrounded Conductor	Minimum Size of Grounding Electrode Conductor
#2 AWG or smaller	#8 AWG (8.4 mm ²)
#1 to #1/0 AWG	#6 AWG (13.3 mm ²)
#2/0 or #3/0 AWG	#4 AWG (21.1 mm ²)
Over #3/0 AWG through 350 kcmil	#2 AWG (33.6 mm ²)

DC Side - To size the DC grounding electrode conductor, first determine which one of the following three methods will be used to connect the DC and AC grounding points in the inverter's two electrical systems (AC and DC) to the common "earth" ground.



Info: There are many variables to consider when choosing the size of the DC grounding electrode conductor. The MP enclosure provides the means to ground both the AC and DC to a single ground, and when feasible, the Single Connection to Ground (Method 1) is recommended. With this method the NEC allows a #6 AWG wire, which makes the overall installation simpler and less costly.

1. Single Connection to Ground (Method 1): The AC Grounding Electrode Conductor (GEC-AC) is bonded to the DC ground point and the DC Grounding Electrode Conductor (GEC-DC) is the *only connection* to the grounding electrode, which must be a rod, pipe, or plate electrode (see Figure 3-31).

Normally the size of the DC grounding electrode conductor must be no less than the size of the battery bank's negative cable. However, in this method, since there is only one connection to the ground rod the NEC allows an exception. The DC grounding electrode conductor is not required to be larger than #6 AWG (13 mm²) copper. The reasoning for allowing this smaller grounding electrode conductor is that it is only required to stabilize the system voltage with respect to earth, and the other properly-sized conductors in each electrical system will safely carry any fault currents if they occur.

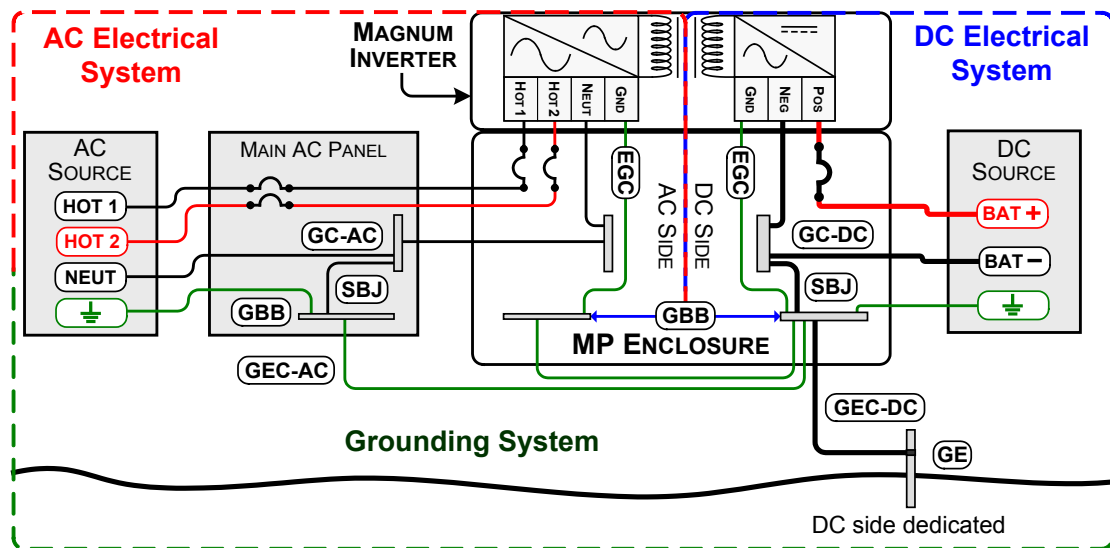

Figure 3-31, Single Connection to DC Ground Rod (Method 1)

3.0 Installation

2. Multiple Connections to Ground - Single Electrode (Method 2): When the AC and DC service panels are near each other, then the AC Grounding Electrode Conductor (GEC-AC) and DC Grounding Electrode Conductor (GEC-DC) can be connected to a single grounding electrode (see Figure 3-32). In this method — since there are multiple connections to the DC grounding electrode — the size of the DC grounding electrode conductor cannot be smaller than the largest conductor in the DC system (usually the battery-to-inverter cable).

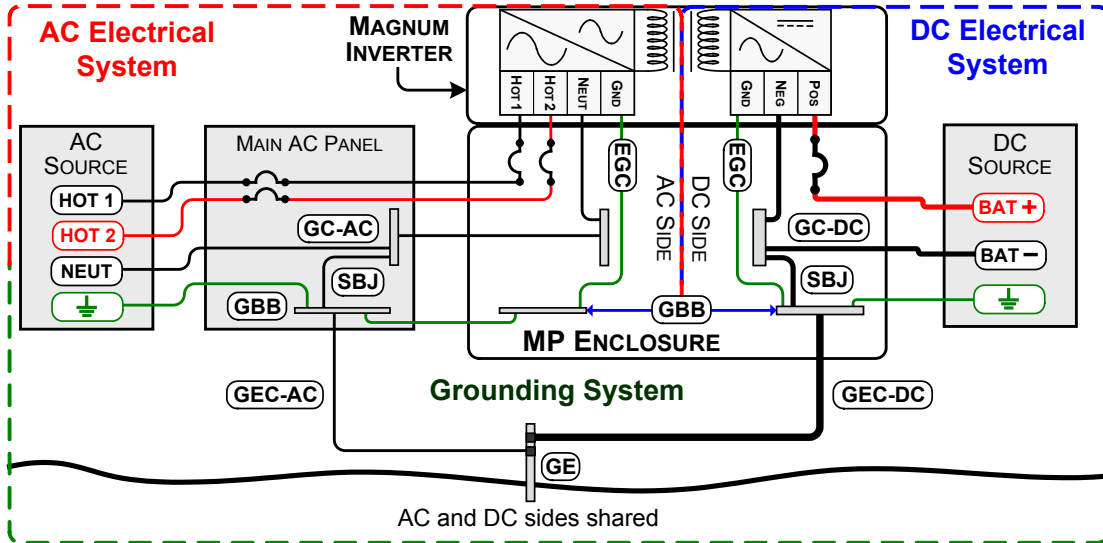

Figure 3-32, Multiple Connections to DC Ground Rod (Method 2)

3. Multiple Connections to Ground - Multiple Electrodes (Method 3): This method uses a separate grounding electrode for the DC system and the AC system (see Figure 3-33). In this method — since there are multiple connections to the DC Grounding Electrode (GEC-DC) — the size of the DC grounding electrode conductor cannot be smaller than the largest conductor in the DC system (usually the battery-to-inverter cable).

The DC Grounding Electrode (GE-DC) must be bonded to the AC Grounding Electrode (GE-AC) to make a grounding electrode system; this Bonding Conductor (BC) cannot be smaller than the largest grounding electrode conductor, either AC or DC.

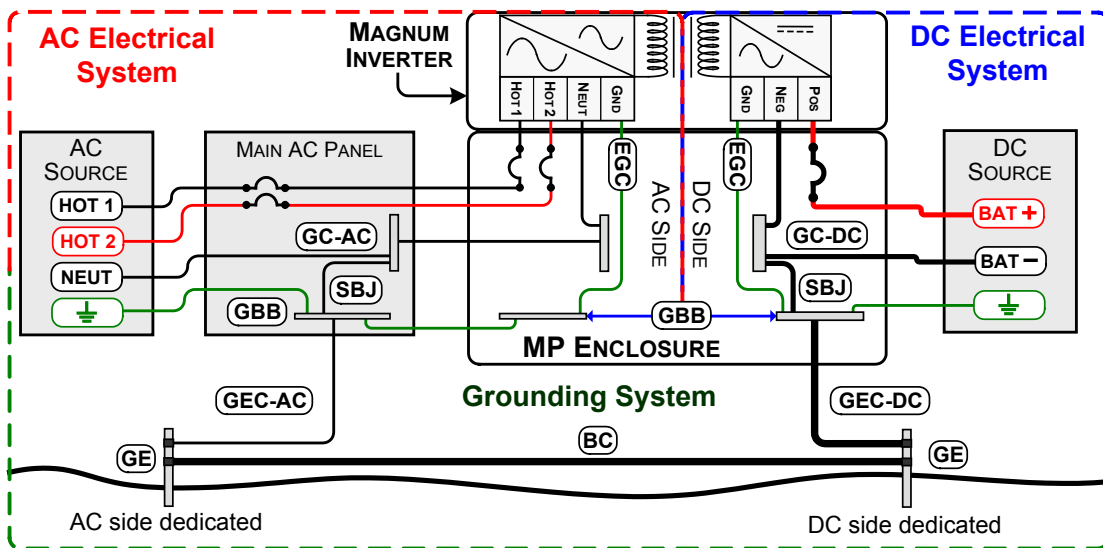

Figure 3-33, Multiple Connections to DC Ground Rod (Method 3)

3.11.2 Equipment Grounding Conductor

The MP enclosure and all other non-current carrying exposed metal surfaces in the entire electrical system that may be accidentally energized must be grounded. The equipment-grounding conductor must be sized to safely carry the maximum ground-fault current likely to be imposed on it from where a ground-fault may occur.

AC Side - When the inverter's AC input circuit breaker provided in the MP enclosure is being used as the inverter's AC overcurrent protection device, the AC Equipment Grounding Conductor (EGC-AC) for the inverter is based on the AC breaker size provided (#10 AWG for all MP models). Connect the AC equipment-grounding conductor from the inverter's AC ground connection to the AC Ground Busbar (GBB) in the MP enclosure (Item 25 in Figure 2-7 or 2-8, Item 22 in Figure 2-9, or Item 16 in Figure 2-10a - depending on your MP model).

DC Side - When the DC circuit breaker provided in the MP enclosure is being used as the inverter's DC overcurrent protection device, the DC Equipment Grounding Conductor (EGC-DC) for the inverter should be #4 AWG, which is based on the 250 amp DC breaker size provided. Connect the DC equipment-grounding conductor from the inverter's DC ground connection to the DC Ground Busbar (GBB) in the MP enclosure (Item 27 in Figures 2-7 or 2-8, Item 25 in Figure 2-9, or Item 26 in Figure 2-10b - depending on your MP model).

If you are using AC or DC overcurrent protection that is different than that provided in the MP enclosure or installing optional DC breakers inside the MP enclosure, in accordance with the NEC/CEC you must determine your equipment-grounding conductors based on the ampere rating of the overcurrent device protecting the circuit conductors. Use Table 3-7 to help determine the equipment-grounding conductor. If the circuit conductors are oversized to compensate for voltage drop, the equipment-grounding conductor must also be oversized proportionally.

Table 3-7, Equipment Grounding Conductor Sizing

Rating of Overcurrent Device	Minimum Size of Copper Ground Wire
15 amp	#14 AWG
20 amp	#12 AWG
30 - 60 amp	#10 AWG
100 amp	#8 AWG
200 amp	#6 AWG
300 amp	#4 AWG
400 amp	#3 AWG

3.11.3 System Bonding Jumper

The MP enclosure provides the single point of ground [System Bonding Jumper (SBJ)] for the AC and DC system. If the MP enclosure is the central connection point for all ground wiring (usually in an off-grid system) and there is no other connection to ground from neutral (in the AC system) or negative (in the DC system), then leave the ground bond connections in place. Remove any other neutral to ground connection in the AC system, such as in other electrical sub-panels; or, any negative to ground connection in the DC system.

For utility connected systems where the neutral and ground are already bonded in the main utility circuit breaker box (AC distribution panel), the NEUTRAL-GROUND wire MUST BE REMOVED from the MP enclosure. See Section 3.9 to remove this neutral to ground connection.



Info: Inverters and portable generators that have electrical outlets usually have the neutral and ground bonded internally. These types of devices are not recommended to be connected to the MP/inverter system as they would first need to be modified to separate the neutral and ground bonding internally.

For systems or devices that connect the DC negative to ground independently (i.e., separate DC main electrical distribution panel or PV-GFP device), the NEGATIVE-GROUND busbar (Item 27 in Figure 2-9, or Item 29 in Figures 2-7, 2-8 and 2-10b - depending on your MP model) MUST BE REMOVED inside the MP enclosure. See Section 3.10 to remove this negative to ground connection.

3.0 Installation

3.12 Installation Checklist

Use this checklist as a final review to ensure all essential steps of the MP enclosures installation have been completed before proceeding with the functional test.

Mounting

The MP enclosure/inverter system is securely mounted in a clean, dry, and ventilated area.

The MP enclosure/inverter system is not mounted in the same enclosure as maintenance-free or vented type batteries.

The MP enclosure is mounted in a 'vertical only' position.

There is adequate clearance to access the front and to view/adjust the remote (if installed).

DC Wiring

Inverter Side:

The inverter is correctly placed on the MP enclosure with the inverter's DC terminals attached to the inverter DC negative and positive cables inside the MP enclosure.

Battery Bank Side:

An appropriately sized DC cable is routed from the positive (+) battery terminal and attached to the bottom terminal of the inverter DC disconnect breaker inside the MP enclosure.

An appropriately sized DC cable is routed from the negative (-) battery terminal and attached to the busbar which is connected to the bottom terminal of the DC shunt inside the MP enclosure.

The DC hardware is stacked correctly (refer to Figure 3-20).

The DC cable connections are torqued correctly (refer to Tables 3-1 to 3-3).

AC Wiring

To Inverter: The AC wires are appropriately sized and routed from the inverter AC Input breaker(s) inside MP enclosure to the inverter's AC input terminals.

From Inverter: The AC wires are appropriately sized and routed from the inverter's AC output terminals to the AC output busbars (INV HOT 1 OUT, INV HOT 2 OUT, AC NEUTRAL and GROUND) inside MP enclosure.

To Main AC Electrical Panel: The AC wires are appropriately sized and are routed from the AC input busbars (AC LEG 1 IN, AC LEG 2 IN, AC NEUTRAL and GROUND) inside MP enclosure to the circuit breaker in the main AC electrical panel (i.e., main panel) powered by the generator or grid. Use Table 3-4 to determine the AC wire size to/from the MP enclosure.

To Inverter AC Load Panel: The AC wires are appropriately sized and routed from the AC output busbars (AC LEG 1 OUT, AC LEG 2 OUT, AC NEUTRAL and GROUND) inside MP enclosure to the main circuit breaker in the electrical panel powered by the inverter (i.e., sub-panel). Use Table 3-4 to determine the AC wire size to/from the MP enclosure.

AC wires connected to the busbars/circuit breakers are torqued correctly (see Tables 3-1 to 3-3).

Grounding

There is only one bonding connection to ground for the DC electrical system (negative to ground) and one bonding connection to ground for the AC electrical system (neutral to ground). These bonding connections may be connected to the same grounding electrode system (ground rod). If separate electrodes are used, they must be bonded together.

The exposed metal parts of equipment are properly grounded.

Equipment grounding conductors are properly sized.

Electrical Connections

Connectors are listed for the intended use and environment (inside, outside, wet, etc.).

Pressure/screw terminals tightened to the recommended torque specification.

Terminals containing more than one conductor are listed for multiple conductors.

Connectors using flexible, fine-stranded conductors are listed for use with such conductors.

All electrical terminal connections in the inverter are re-torqued to tighten any connections that may have loosened since the initial installation.

Conductors and General Wiring Methods

Conductors are rated for the application and the environment.

Standard building-wire conductors and appropriate wiring methods are used.

Note: Welding, marine, locomotive (DLO), and auto battery cables don't meet NEC/CEC requirements. Flexible RHW or THW cables are available, but these cables require very limited, specially listed terminals. When the battery conductors leave the battery enclosure, the conductors must be of a type listed for use in conduit (RHW or THW).

The DC and AC color codes for the ground conductors are the same – grounded conductors are white and equipment-grounding conductors are green, green/yellow, or bare (no insulation).

All wiring insulation have a minimum rating of 150V, 75°C when using only 120V AC power/inverter; or, with a minimum rating of 300V, 75°C when using 120/240V AC power/inverter.

Strain reliefs/cable clamps or conduit are used on all cables and cords.

Conductors between the inverter and battery bank are installed in conduit.

No multi-wire branch circuits when single, 120V AC inverters are connected to 120/240V AC load centers.

Note: A multi-wire branch circuit is a three-wire circuit with a shared neutral for two, 120V AC branch circuits.

Overcurrent Protection

Properly sized and rated disconnects and overcurrent devices are used in the ungrounded conductors in each circuit (AC and DC).

Overcurrent devices in the DC circuits are listed for DC operation.

DC overcurrent protection is provided at the batteries when they are located in a separate room, or more than five feet away from the MP enclosure.

The DC overcurrent protection device and battery cables to the inverter are sized for the inverter's DC input current.

Note: Inverter's DC input current is calculated using rated AC output in watts, divided by lowest battery voltage, divided by inverter efficiency at that power level.

When the inverter DC disconnect breaker inside the MP enclosure is not used as the DC overcurrent device, high interrupt, listed, DC-rated fuses or circuit breakers must be used in the battery cable circuits.

Batteries

Battery terminals and other live parts are guarded, and adequate working space around the battery bank is provided.

Batteries are installed in well-vented areas (garages, outbuildings), and not in living areas.

Adhere to the "IMPORTANT BATTERY SAFETY INSTRUCTIONS" at the beginning of this manual.

Marking

Battery bank is labeled with maximum operating voltage, equalization voltage, and polarity.

Utility Back-up Systems: Exterior visible sign indicating the building contains an inverter back-up system and identifies the locations of the disconnects.

An electrical system supplied by a 120V AC only inverter includes a label warning against connecting multi-wire branch circuits.

All required "Warning" and "Caution" signs/labels are installed in the proper locations, as required in the NEC/CEC.

Inspection

Electrical inspection complete and a Certificate of Electrical Inspection has been issued by the local Authority Having Jurisdiction (AHJ). The local AHJ or inspector has the final say on what is or is not acceptable. Local codes may modify the requirements of the NEC/CEC.

Part of this checklist is obtained from the Photovoltaic Electrical Power Systems Inspector/Installer Checklist created by John Wiles, Southwest Technology Development Institute, New Mexico State University, June 2006.

3.0 Installation

3.13 Functional Test

After all electrical connections from the MP enclosure to the inverter, batteries, AC source, and the electrical panel have been completed, follow the steps below to test the installation of the MP enclosure and to verify proper operation of the AC breakers.



WARNING: During this functional test, the front cover is removed and exposes personnel to potential dangerous voltages and shock hazards inside the MP enclosure that may cause damage, injury, or death. If you do not have experience working with AC and DC voltage circuits, do not attempt this test – use an experienced electrical installer.



CAUTION: During this functional test, if any step cannot be verified or is incorrect, stop and recheck/correct the connections before proceeding to the next step.

1. Turn OFF all breakers (i.e., **DC Disconnect**, **INV BYP**, **AC OUT**, and **INV IN**) in the MP enclosure.
2. Perform DC voltage/polarity checks (refer to Figure 3-34 for single enclosures or Figure 3-35 for dual enclosures):

a. Use a DC voltmeter or multimeter (set to DC Volts) and place the negative (-) meter probe (usually black) on the negative battery busbar (bottom of the DC shunt). Then place the positive (+) meter probe (usually red) at the bottom of each DC breaker. Verify the battery voltage is correct for your particular inverter model (i.e., 24-volt battery bank for a 24-volt inverter).

b. Ensure the voltmeter reading is a positive number. When the probes are connected correctly (positive probe on DC circuit breaker and negative probe on battery negative busbar) and the number is positive, the polarity of the battery voltage is correct.

If the battery voltage and polarity are correct, apply battery power to the inverter by turning the inverter DC disconnect breaker(s) to the ON (up) position.

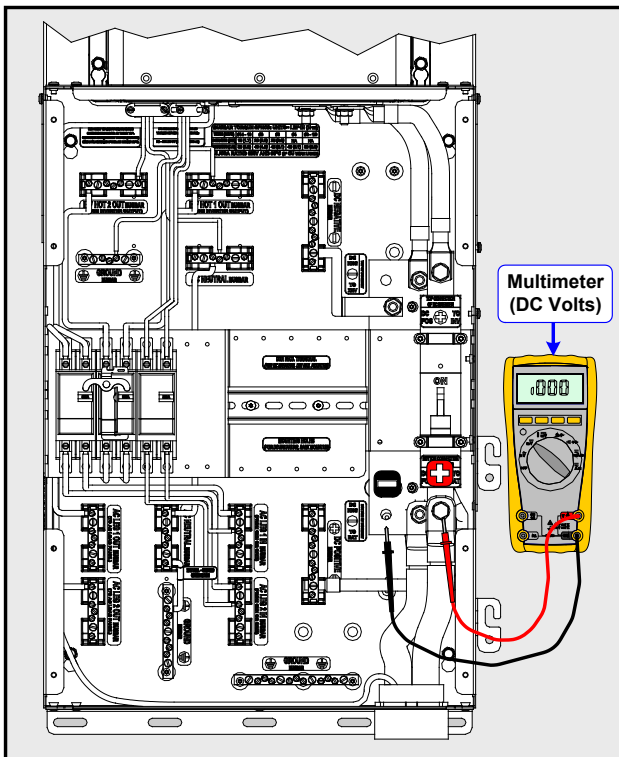

Figure 3-34, DC Voltage Checks - Single Enclosures

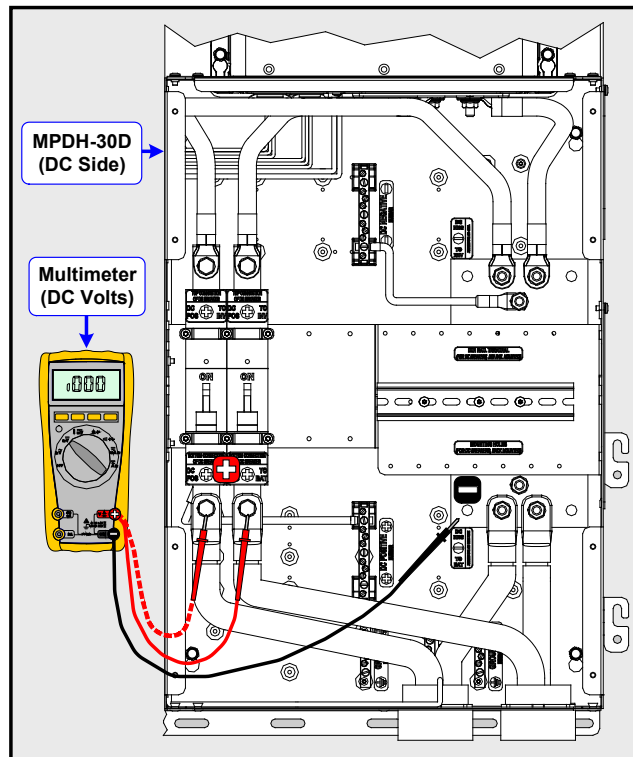

Figure 3-35, DC Voltage Checks - Dual Enclosures (DC Side)

3. AC breakers connections/operation:

Note: For the following steps, refer to Figure 3-36 for MPSL-30D and MPSH-30D models, Figure 3-37 for the MPSL-60S models, and Figure 3-38 for MPDH-30D models.



CAUTION: Ensure you have read your inverter's owner's manual and are familiar with the power-up test for your particular inverter and remote control.

a. Now that the appropriate battery voltage is connected to the inverter, turn OFF all inverter loads in the inverter load panel (i.e., sub-panel) and turn the inverter ON.



Info: If the inverter does not turn on, refer to the Troubleshooting section for your particular inverter.

b. Connect an AC voltmeter (or multimeter set to AC Volts) to the **Inverter AC Output Terminals** and verify the correct AC voltage from the inverter. Refer to Figure 3-36, 3-37, or 3-38 (depending on your MP model) to determine the correct inverter AC output voltage.



Info: If the inverter has a Search mode feature, the inverter's AC full output voltage will not be present/on until Search is turned OFF, or a large enough light bulb is connected to bring the inverter out of Search mode.

If using a Magnum inverter, use a light bulb that requires more than 5 watts (5 watts is the default setting) to bring the inverter out of Search mode; or, turn the Search mode off (inverter full output will always be on) with a remote control (i.e., ME-RC, ME-ARC, or ME-RTR).



CAUTION: To prevent damage to valuable equipment, DO NOT connect anything to the output of the MP but a light bulb until all wiring and voltages are confirmed to be correct.

c. Turn ON the **AC OUT**¹ breaker in the MP enclosure and confirm that the inverter AC output voltage is passing thru the **AC OUT** breaker by verifying that the inverter AC output voltage is present on the **AC Output Terminals**.

d. Turn ON the **INV BYP**¹ breaker in the MP enclosure (BYPASS Operation) and verify that the inverter AC output voltage is no longer present on the **AC Output Terminals** (all voltage readings should be 0 volts AC).

e. Turn the inverter OFF.

f. Apply power from an external AC source (utility grid or AC generator) to the **AC Input Terminals** and verify the correct AC voltage from the external AC source. Refer to Figure 3-36, 3-37, or 3-38 (depending on your MP model) to determine the correct AC input voltage.

g. Connect the voltmeter to the **AC Output Terminals** and check that the external AC source voltage is passing thru the **INV BYP** breaker by verifying the AC source voltage is now present on the **AC Output Terminals**.

h. Turn ON the **AC OUT**¹ and **INV IN** breakers in the MP enclosure (NORMAL Operation) and wait for the inverter to connect to the external AC source (approximately 30 seconds). Verify that the external AC source is present on the **AC Output Terminals**.



Info: Even though the inverter is turned off, with the external AC source connected and the **INV IN** breaker turned ON, the external AC source will connect to the inverter — after a brief period of time (normally within 30 seconds) — and pass-thru the **AC OUT** breaker to the **AC Output Terminals**.

This concludes the MP functional test. If all steps pass, the MP enclosure is ready for use. Disconnect all power to the MP enclosure and proceed to Section 3.14 to install the front cover.

If any of the steps fail, recheck your wiring connections within the Installation section and/or refer to the Troubleshooting section for your inverter.

Note 1 - The INV BYP and AC OUT breakers are interlocked together. Physically turning ON one will turn OFF the other, and vice versa.

3.0 Installation

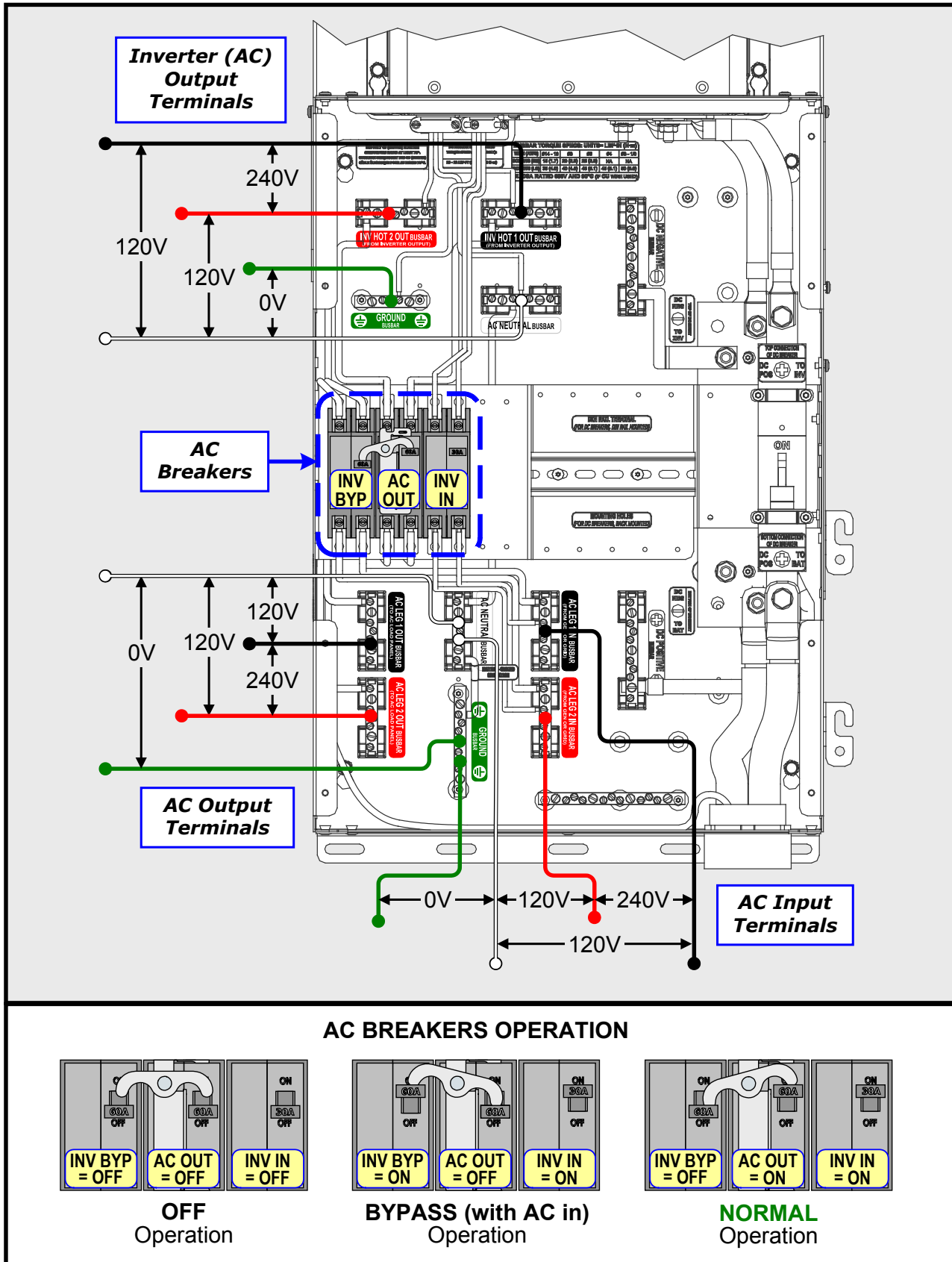

Figure 3-36, AC Voltage Checks - MPLS-30D and MPSH-30D Models

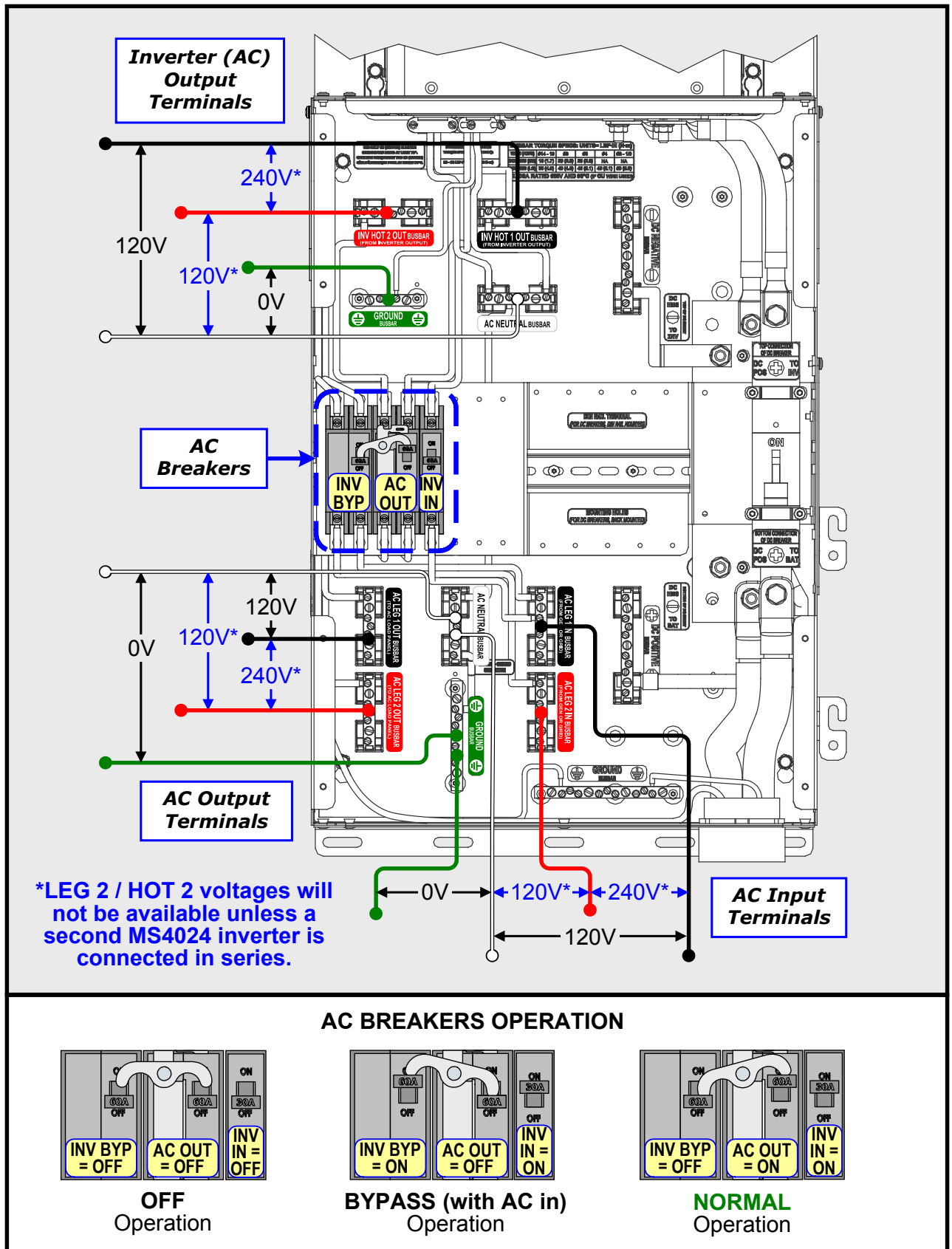

Figure 3-37, AC Voltage Checks - MP5L-60S Models

3.0 Installation

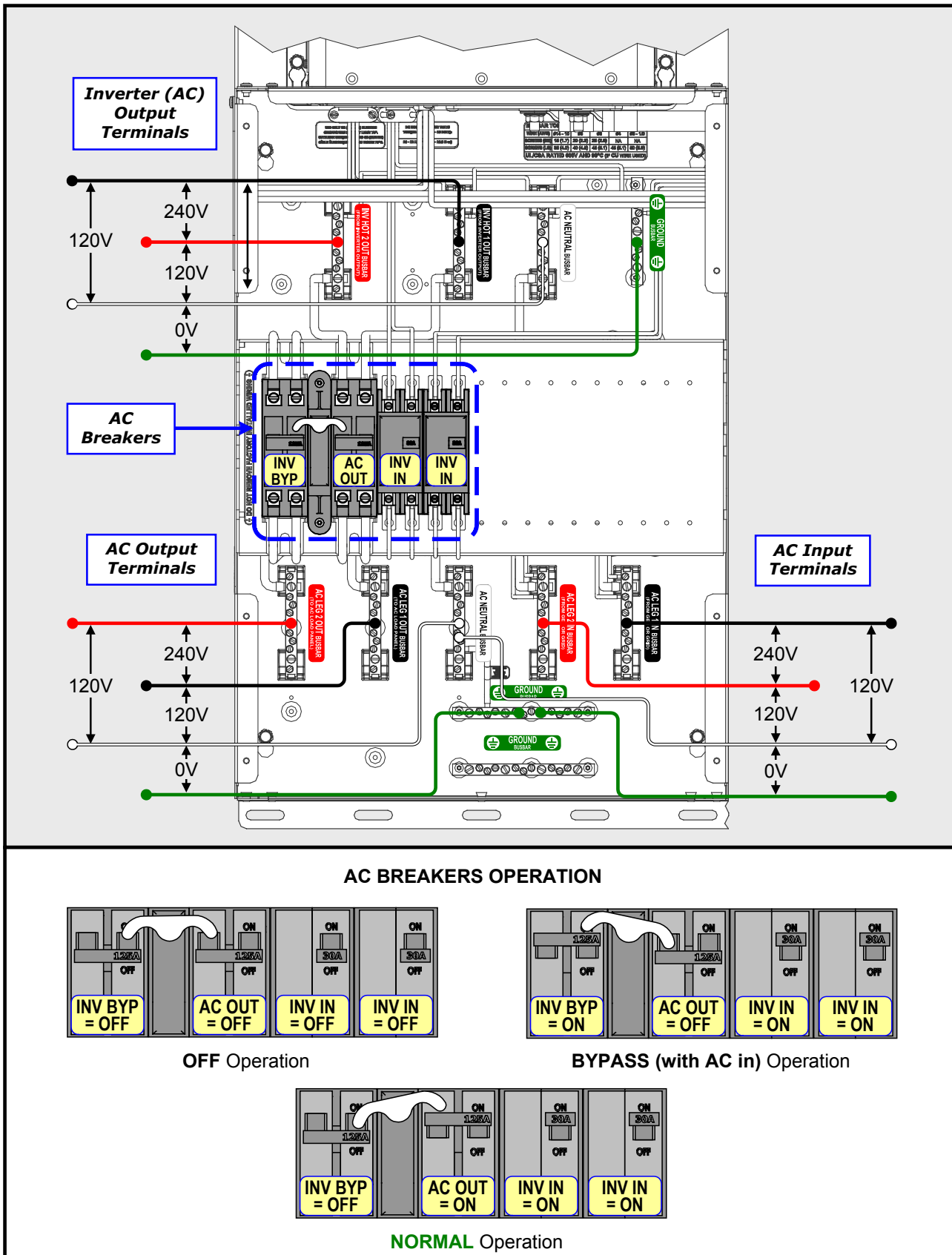

Figure 3-38, AC Voltage Checks - MPDH-30D (AC Side) Models

3.14 Attaching Front Covers

Use the screws and washers that were removed in Step 3.3.1 to attach the front cover to the MP enclosure. See Figure 3-39 for MP SL and MP SH models, or Figure 3-40 for MP DH models.



Info: The MP enclosure uses #10-32 x 3/8" Pan head, T25 Torx drive screws, and #10-32 lock washers to hold each front cover in place. The single enclosures (MP SL and MP SH models) use a total of 8 of these screws/washers, the dual enclosure (MP DH model) uses a total of 16 of these screws/washers.

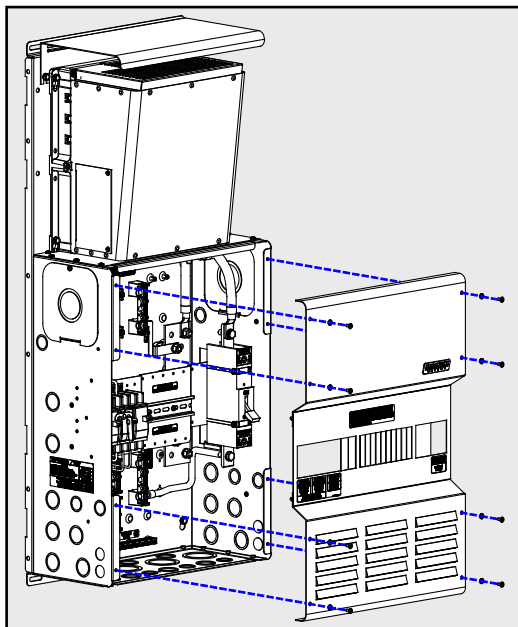

Figure 3-39, Attaching Front Cover - MP SL/MP SH Models

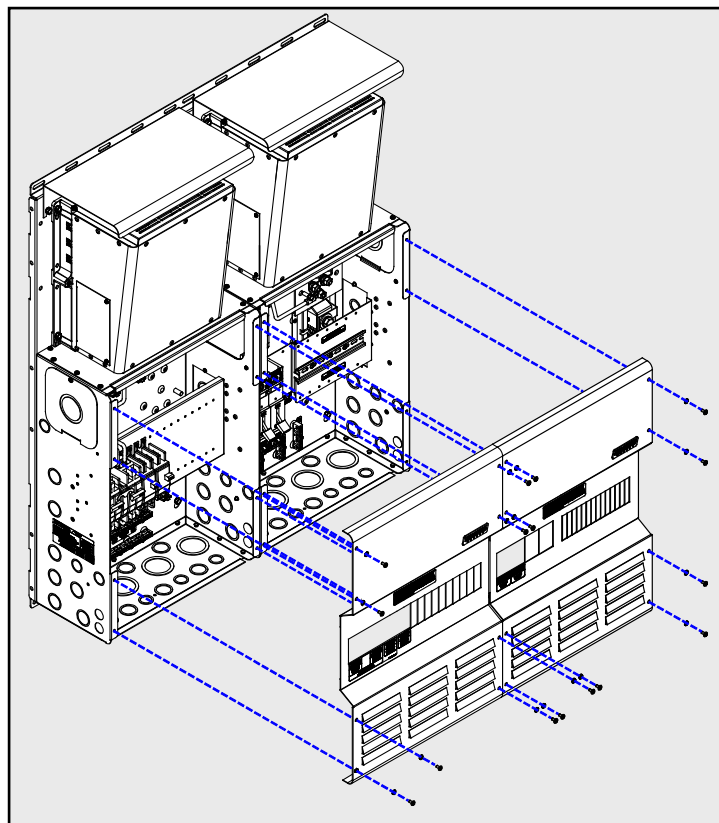

Figure 3-40, Attaching Front Covers - MP DH Models

After the front cover's are attached, open and close all circuit breakers, checking for correct alignment and free operation with the cover now in-place.

The hardware installation procedures for the MP enclosure are complete, if multiple inverters are installed, ensure the inverters are labeled to identify their relationship to one another (see Section 3.15). Otherwise, proceed to Section 5.0 to familiarize yourself with the operation of the MP/inverter system. Also, refer to the Appendix section to learn about the different options available for use with your MP/inverter system.

3.0 Installation

3.15 Master/Slave Identification Label Set

To help reduce operator and maintenance errors resulting from incorrect identification of the inverters and circuit breakers, a Master/Slave Identification Label Set is provided. After the MP enclosure/ Inverter system is wired and tested for proper operation, refer to Figure 3-41 to apply the labels to the front cover of each inverter and to each circuit breaker in the MP enclosure. These labels allow the operator to clearly identify the AC and DC breakers wired to each inverter; and to know the relationship of each inverter to one another when connected in a parallel-stacked configuration.

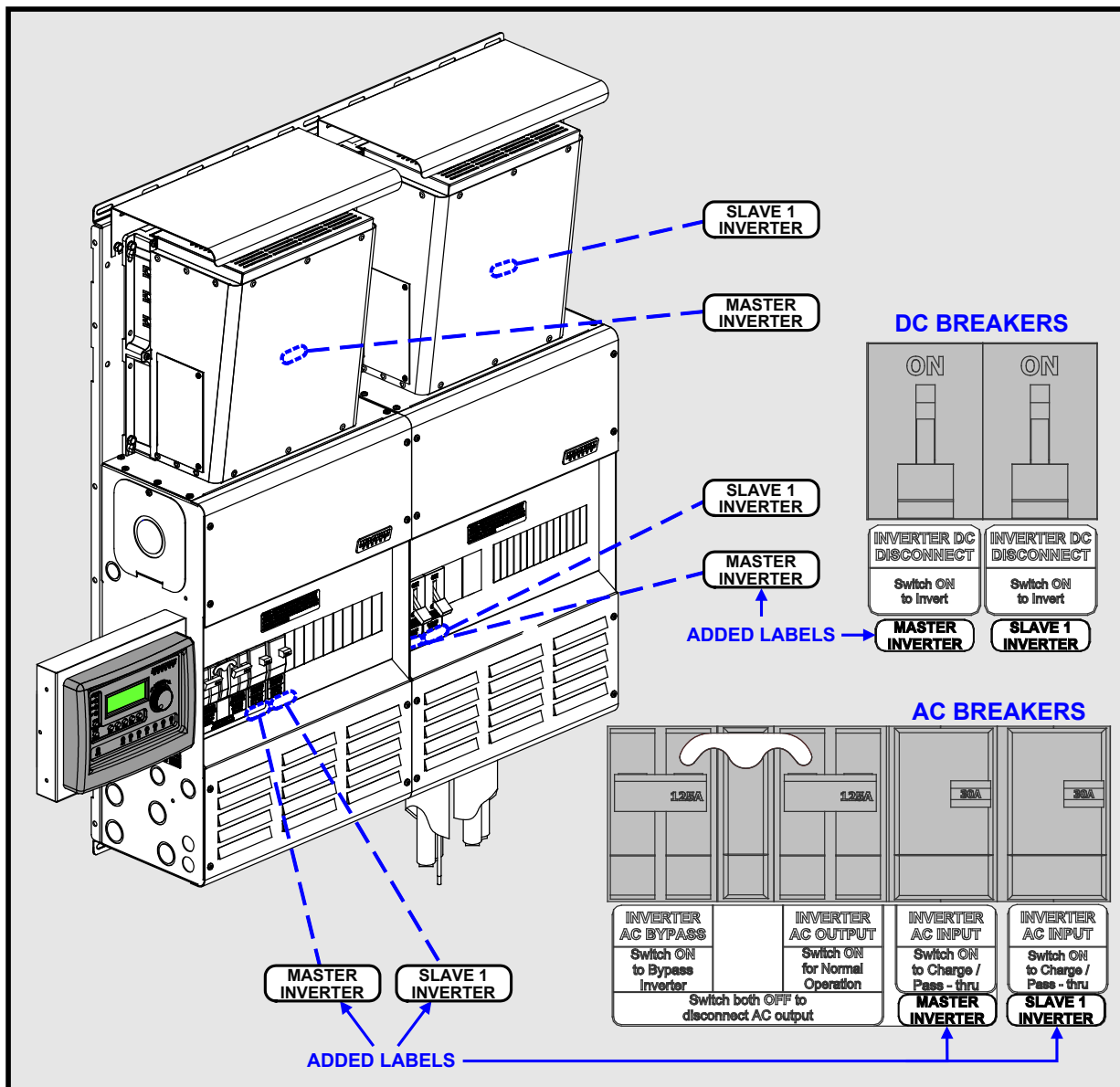

Master/Slave Identification Label Set

MASTER INVERTER	SLAVE 1 INVERTER	SLAVE 2 INVERTER	SLAVE 3 INVERTER
MASTER INVERTER	SLAVE 1 INVERTER	SLAVE 2 INVERTER	SLAVE 3 INVERTER
MASTER INVERTER	SLAVE 1 INVERTER	SLAVE 2 INVERTER	SLAVE 3 INVERTER
MASTER INVERTER	SLAVE 1 INVERTER	SLAVE 2 INVERTER	SLAVE 3 INVERTER

Figure 3-41, Applying Master/Slave Identification Labels

4.0 Wiring Diagrams

Diagrams of the AC, DC, and communications wiring for the different MP Series enclosures are provided in this section to assist the system installer. Use Table 4-1 to quickly find the wiring diagram for your MP model.



Info: Due to the variety of applications and differences in local and national electrical codes, these wiring diagrams should be used as a general guideline only. They are not intended to override or restrict any national or local electrical codes; and, these diagrams should not be the determining factor as to whether the installation is compliant, that is the responsibility of the electrician and the onsite inspector.

Table 4-1, MP Wiring Diagrams

Wiring Diagrams	MP Enclosure Models			
	MPSL-30D	MPSL-60S	MPSH-30D	MPDH-30D
Inverter AC Input/Output Wiring	Figure 4-2 (MS-PAE Series)	Figure 4-1 (MS4024)	Figure 4-2 (MS-PAE Series)	Figure 4-2 (MS-PAE Series)
Inverter AC Wiring	Figure 4-3a	Figure 4-4a	Figure 4-5a	Figure 4-6a
External AC Wiring	Figure 4-3b	Figure 4-4b	Figure 4-5b	Figure 4-6b
DC Wiring (Inverter and External)	Figure 4-3c	Figure 4-4c	Figure 4-5c	Figure 4-6c and Figure 4-6d
Communications Wiring	Figure 4-3d	Figure 4-4d	Figure 4-5d	Figure 4-6e
Full System Wiring	Figure 4-3e	Figure 4-4e	Figure 4-5e	Figure 4-6f

Description of Wiring Diagrams:

- **Inverter AC Input/Output Wiring** - These diagrams show how to connect the inverter's AC input and output wires, separating them into two bundles (AC Input and AC Output), and routing each bundle thru different strain-reliefs on the inverter.
- **Inverter AC Wiring** - These diagrams show the AC wiring inside the MP enclosure from the inverter's AC input and output wires.
- **External AC Wiring** - These diagrams show the AC wiring inside the MP enclosure to the external AC source (i.e., generator or grid) and the external AC loads (main panel or sub-panel).
- **DC Wiring (Inverter and External)** - These diagrams show the DC wiring inside the MP enclosure to the inverter's DC terminals and the DC wiring to the external DC source (i.e., battery bank).
- **Communications Wiring** - These diagrams show the communications cables wired inside the MP enclosure. These communications cables are for connecting the BTS and remote control into and out of the MP enclosure.
- **Full System Wiring** - These diagrams show all the wiring (inverter AC/DC, external AC/DC, and communications) as a fully complete system with the maximum amount of inverters allowed for each specific model.

4.0 Wiring Diagrams

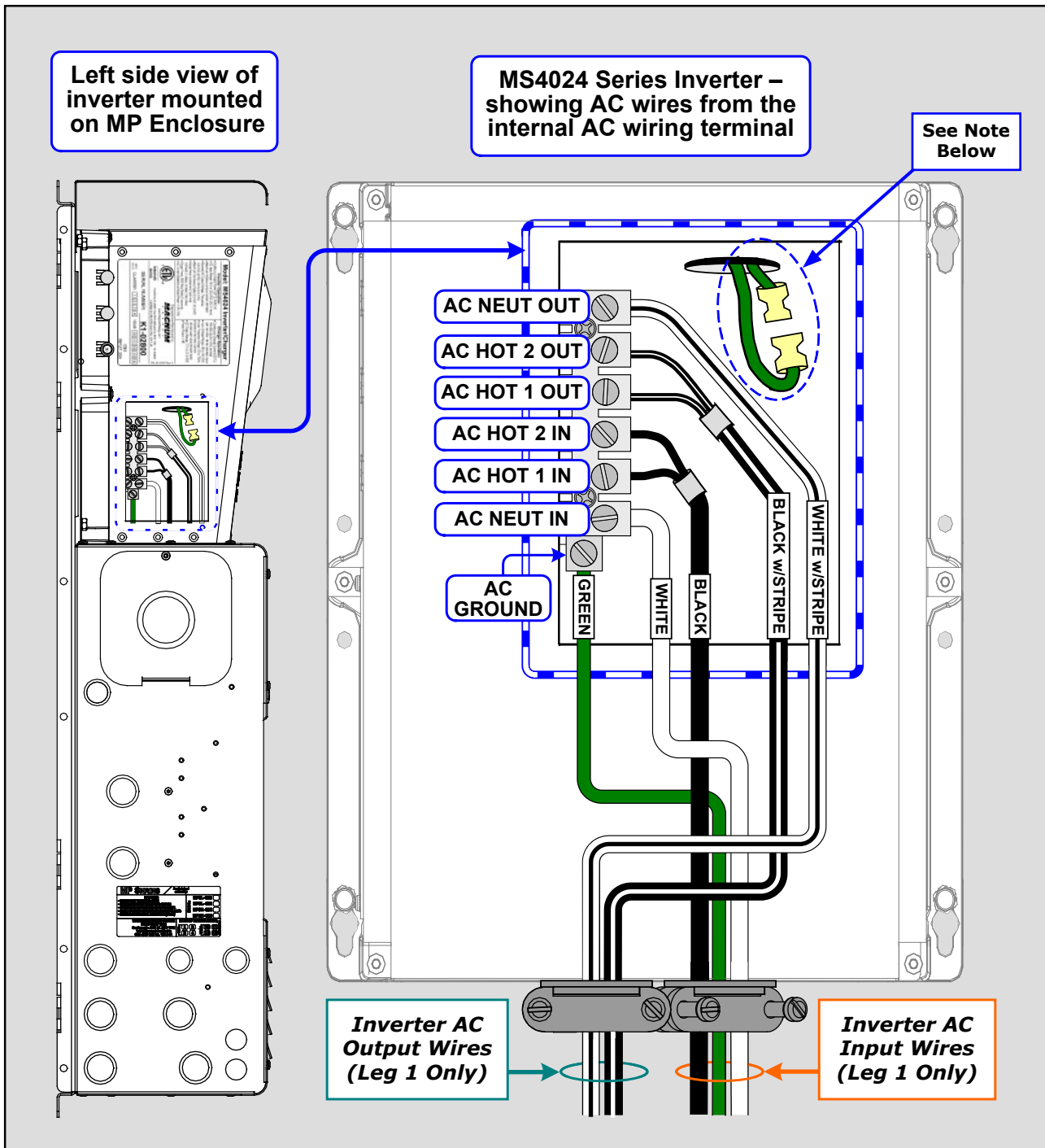

Figure 4-1, Inverter AC Input and Output Wiring Diagram - MS4024



Info: When wiring the MS4024 (or any other MS Series inverter), both the inverter input and output neutral wires must be connected to a AC NEUTRAL busbar inside the MP enclosure. This is because — depending on the inverter's operating mode — the inverter's input and output neutral terminals may not be connected together (i.e., inverter's neutrals are not connected when "inverting", and are combined when "charging").

Note: Because a neutral to ground connection is also made in the MP enclosure, the neutral to ground connection inside the MS4024 must be disconnected. Refer to the MS4024 owner's manual for information on how this is done.

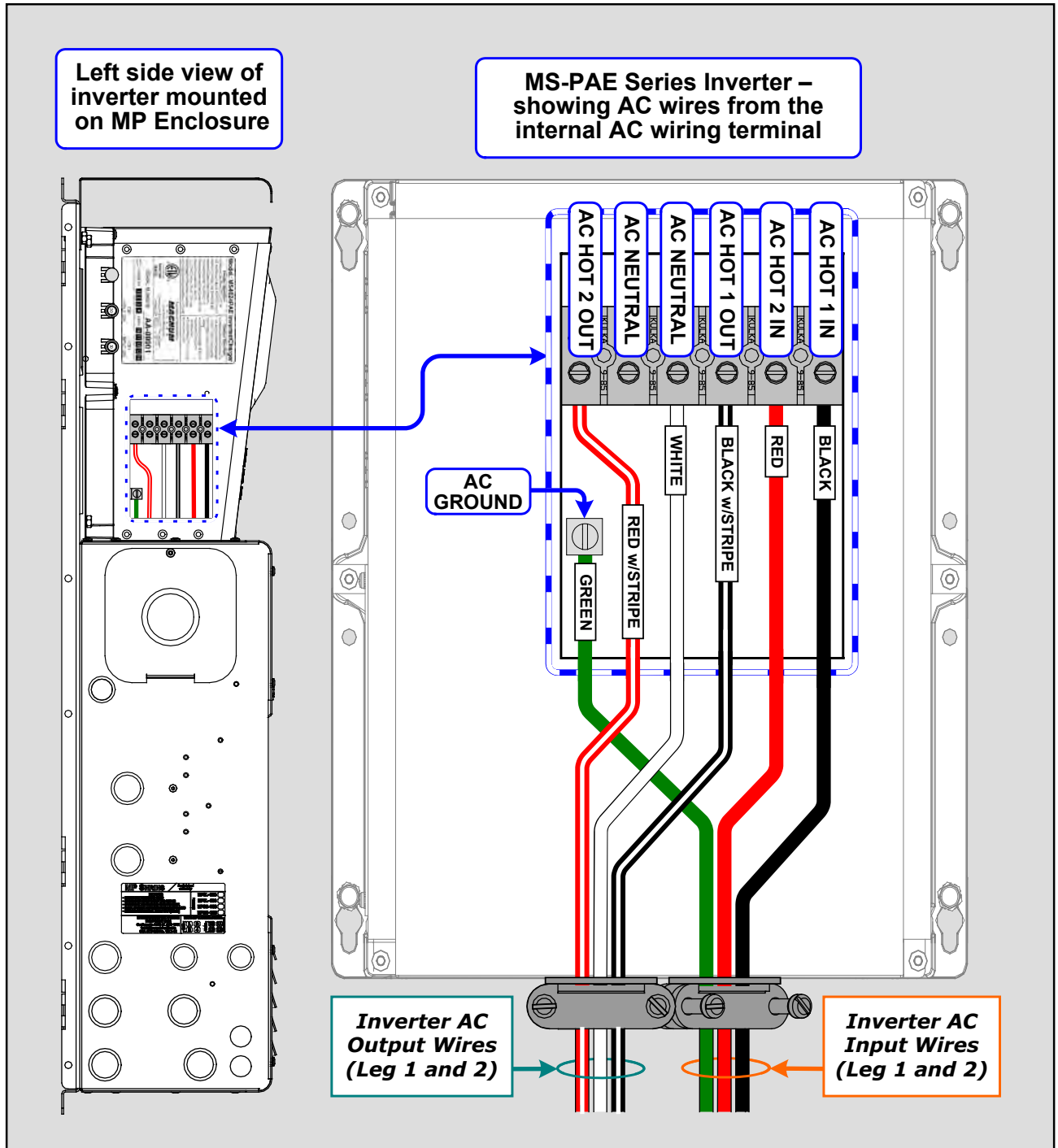

Figure 4-2, Inverter AC Input and Output Wiring Diagram - MS-PAE Series



Info: When wiring the MS-PAE Series inverter, only a single neutral wire (either an inverter input or output neutral wire) is required to be connected to a AC NEUTRAL busbar inside the MP enclosure. This is because the input and output neutral terminals are connected together inside the MS-PAE Series inverter.



Info: The busbars labeled AC NEUTRAL in the MP enclosure ARE connected together, so all neutral connections are in common with each other.

4.0 Wiring Diagrams

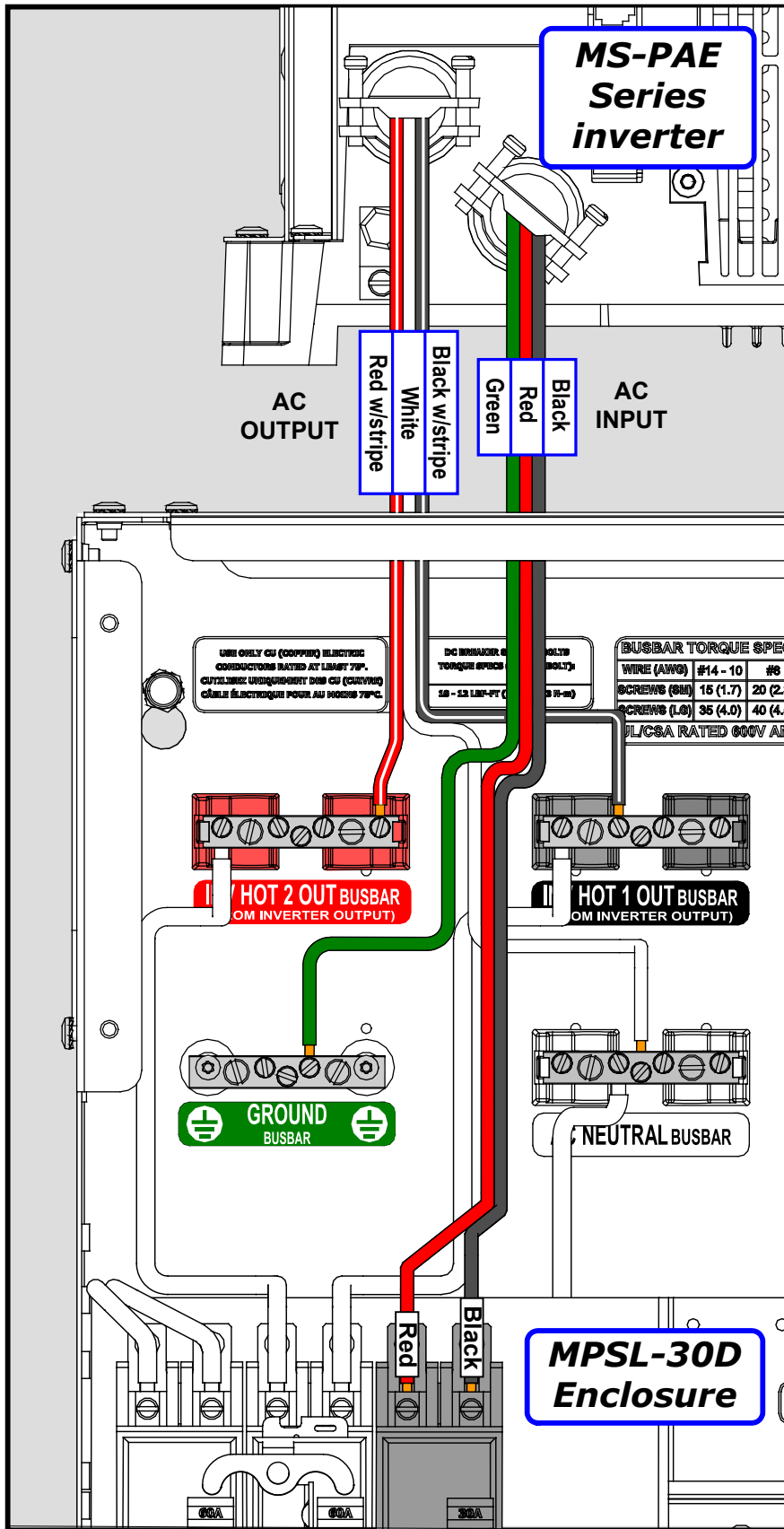

Figure 4-3a, MPSL-30D Inverter AC Wiring

Note: The NEUTRAL-GROUND CONNECTION wire must be removed if a neutral to ground connection is made in the AC Main panel (see section 3.9)

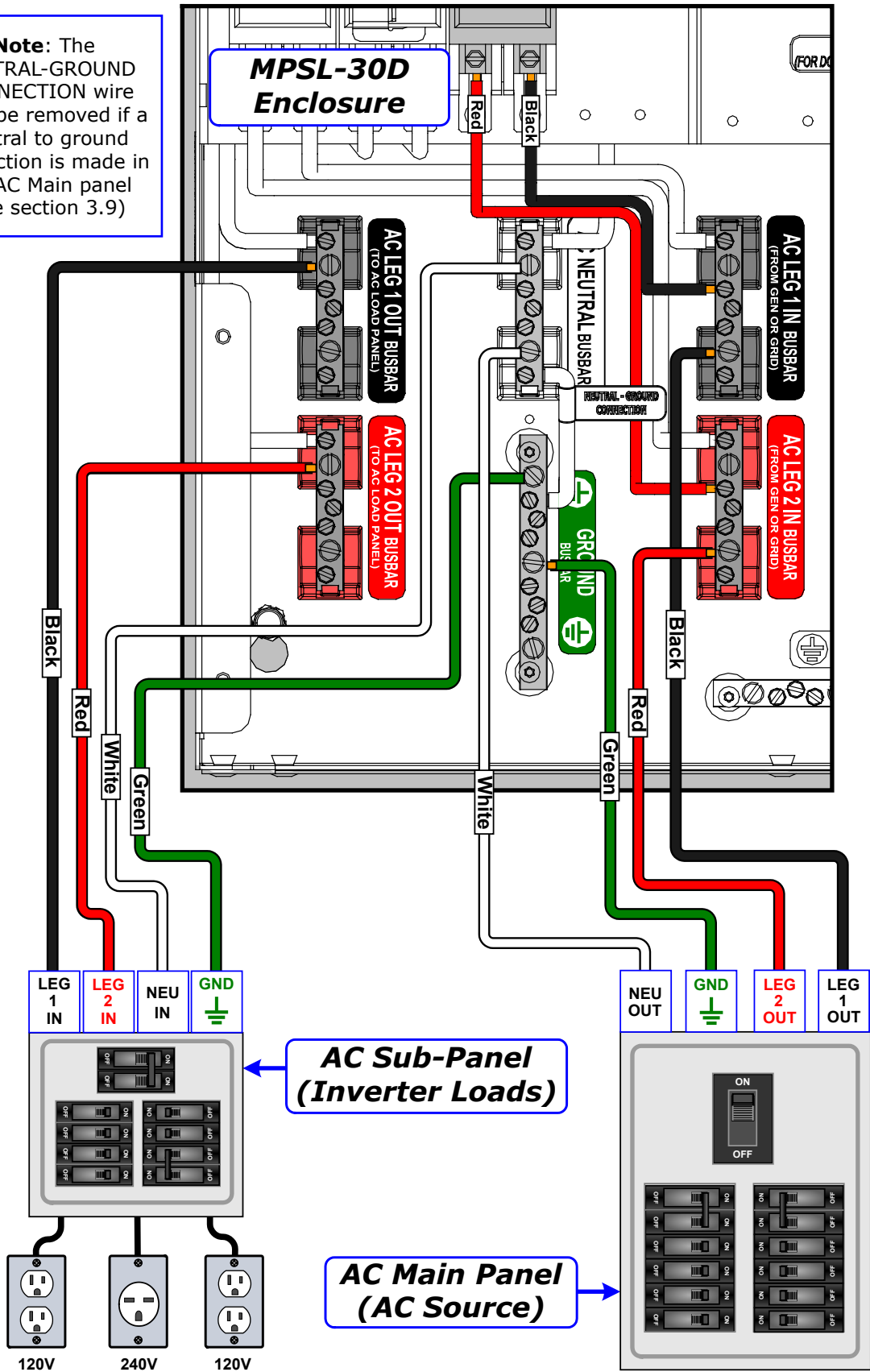

Figure 4-3b, MPSL-30D External AC Wiring

4.0 Wiring Diagrams

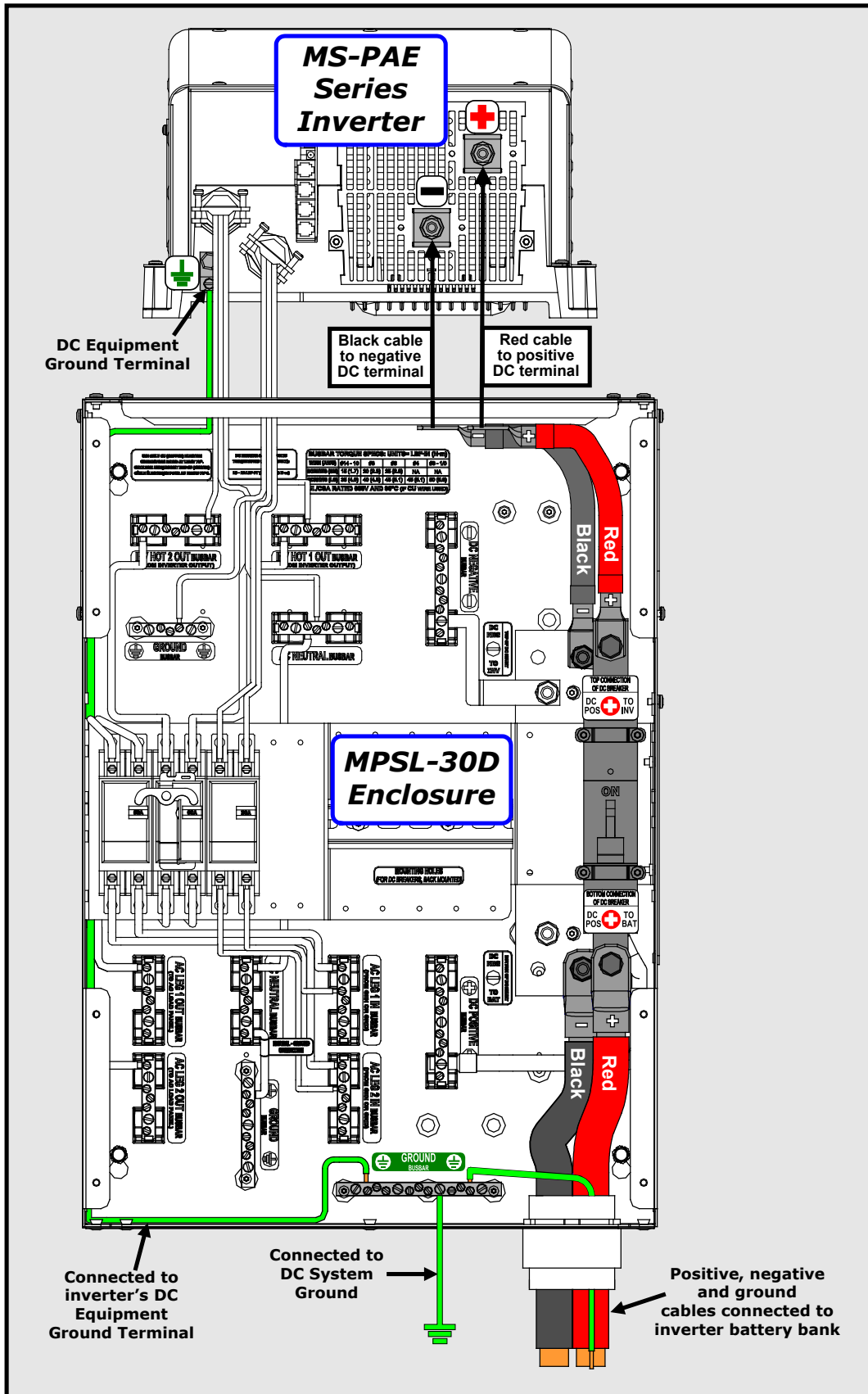

Figure 4-3c, MPSL-30D DC Wiring

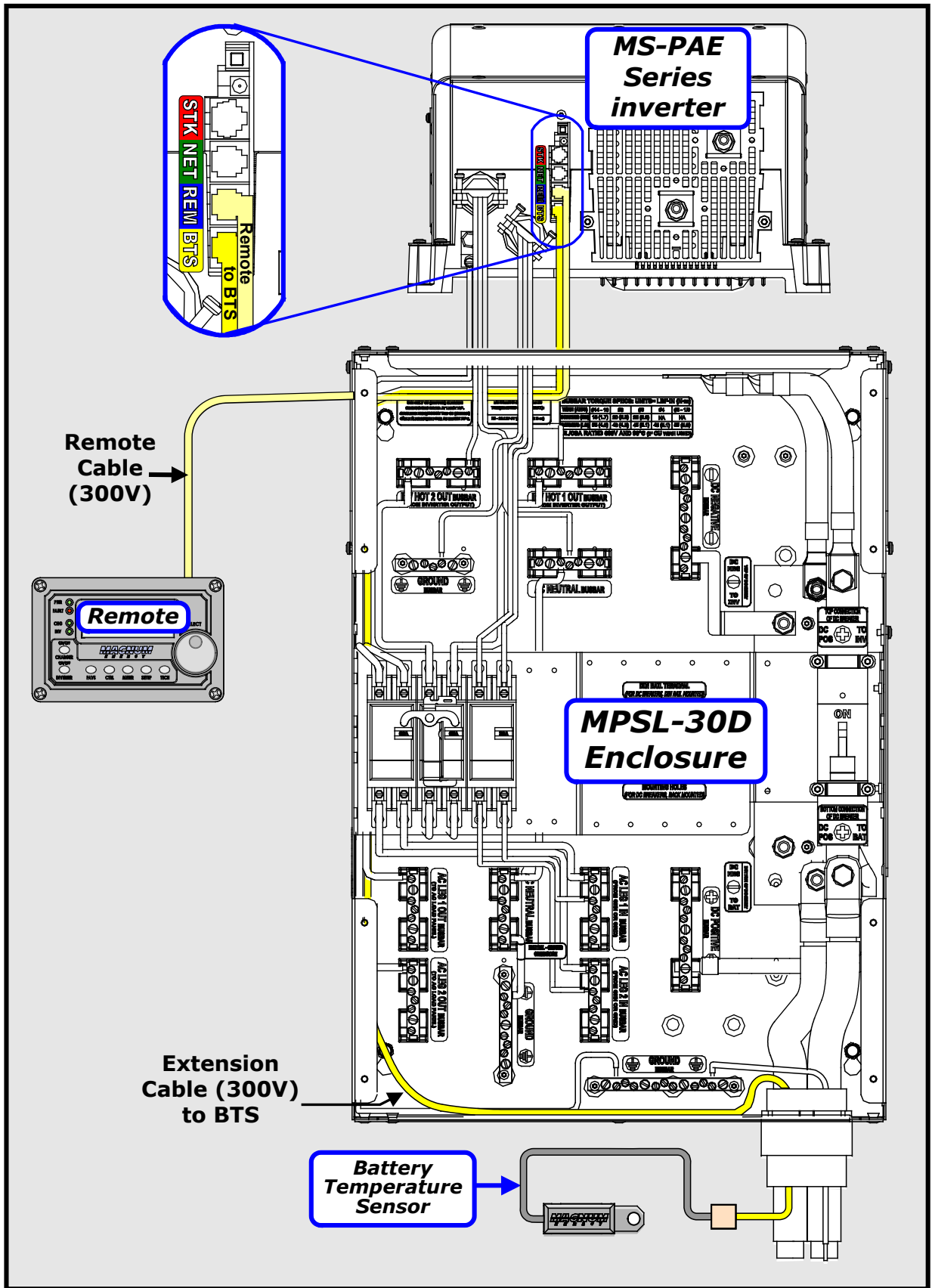

Figure 4-3d, MPSL-30D Communications Wiring

4.0 Wiring Diagrams

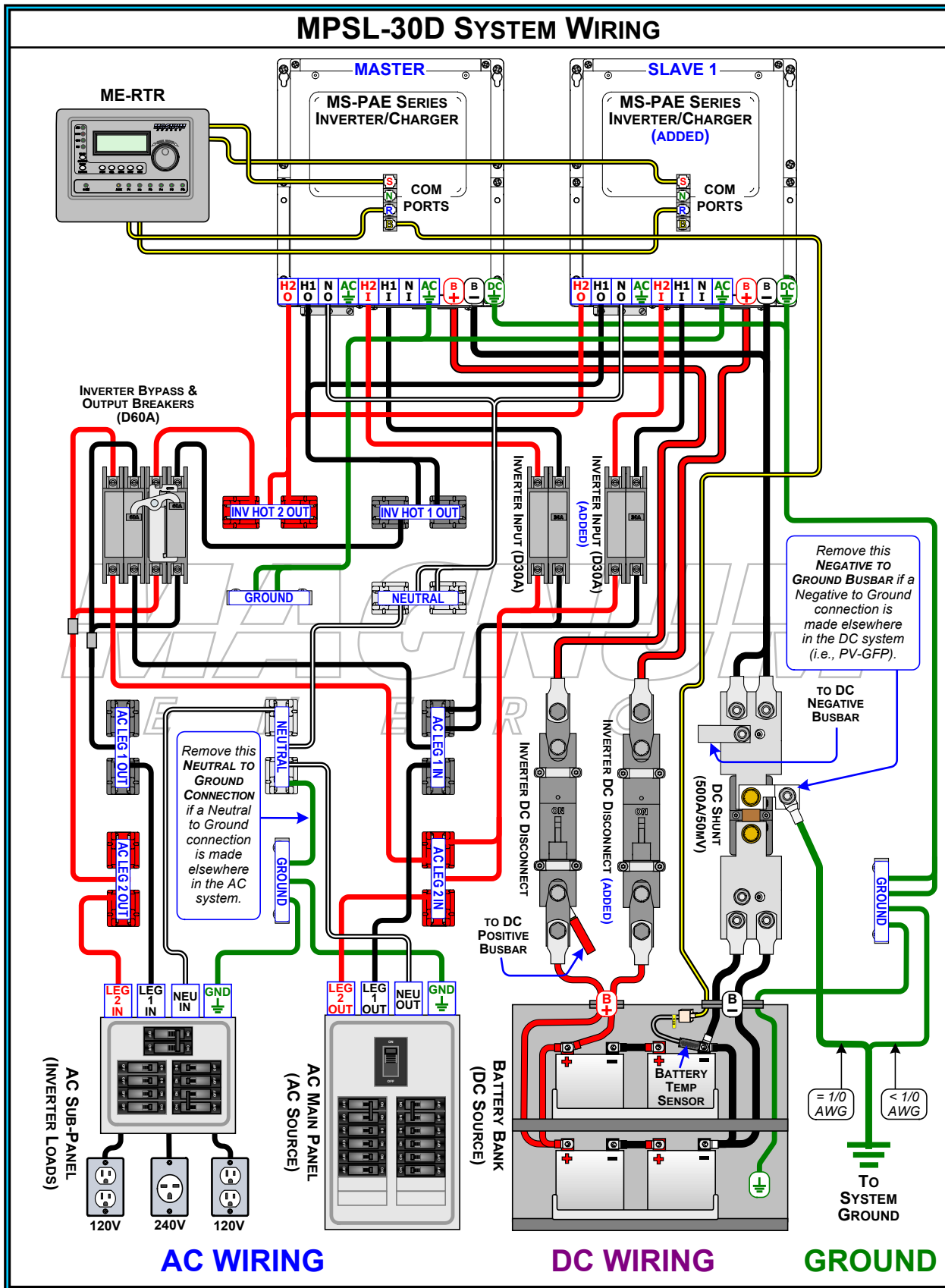
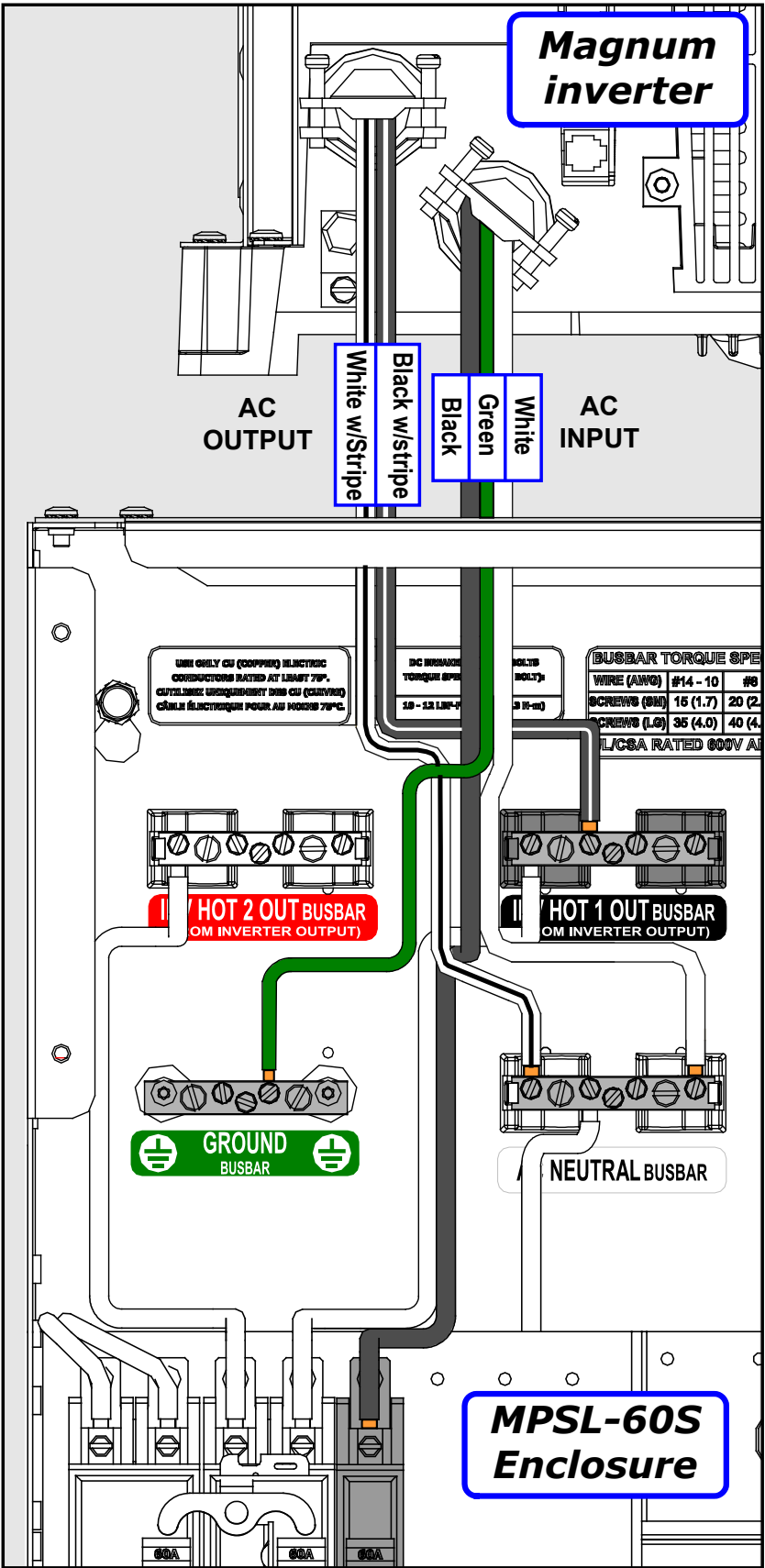

Figure 4-3e, MPSL-30D Full System Wiring Diagram



Note: This figure shows wiring inside the MPSL-60S for one MS4024 - as LEG 1 (120V AC only). A second MS4024 can be connected in a Series-stacked configuration - as LEG 2 (120/240V AC). Refer to information on the MPX Extension models for stacking a second MS4024 in series.

Figure 4-4a, MPSL-60S Inverter AC Wiring

4.0 Wiring Diagrams

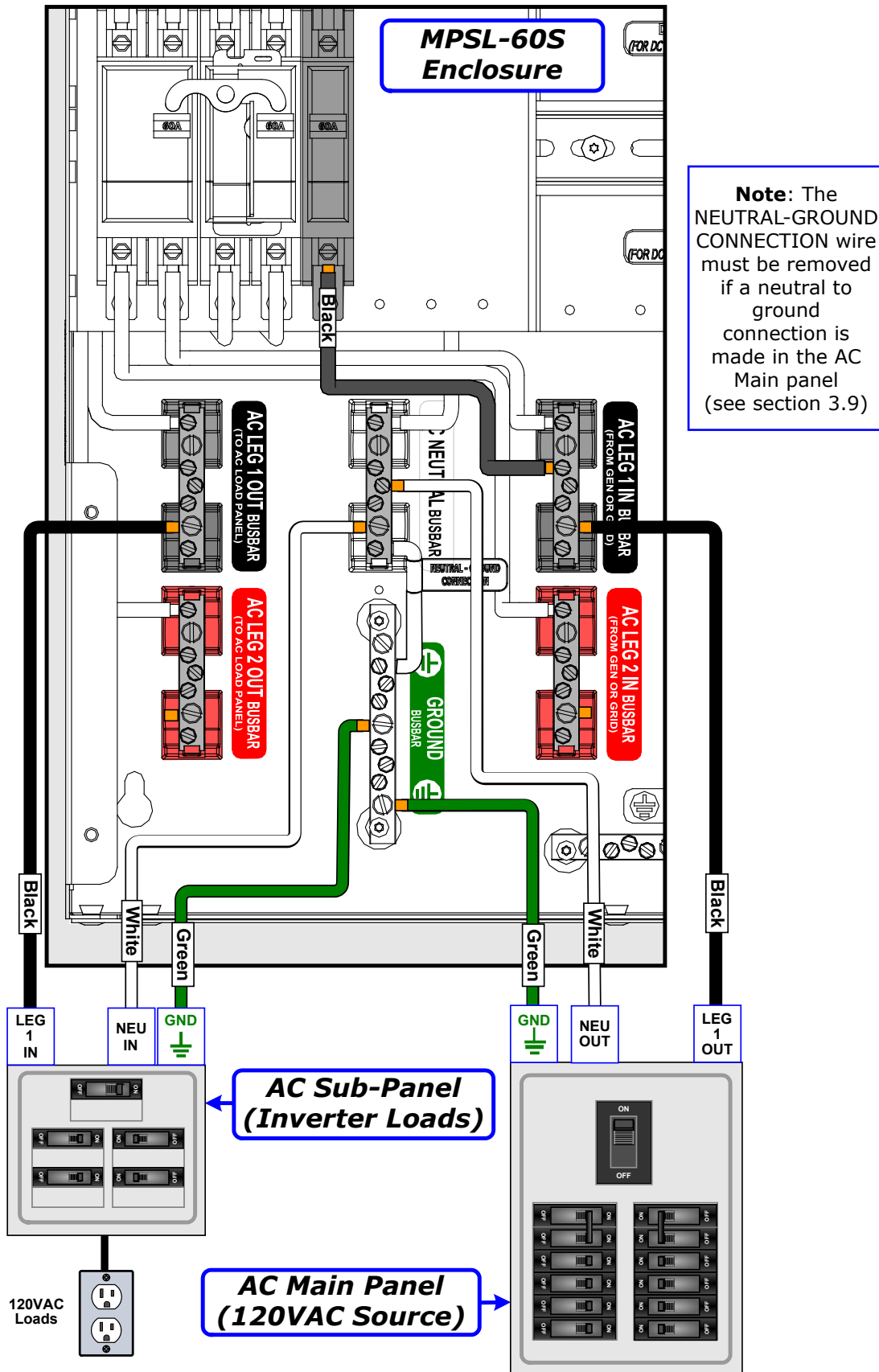

Figure 4-4b, MPSL-60S External AC Wiring

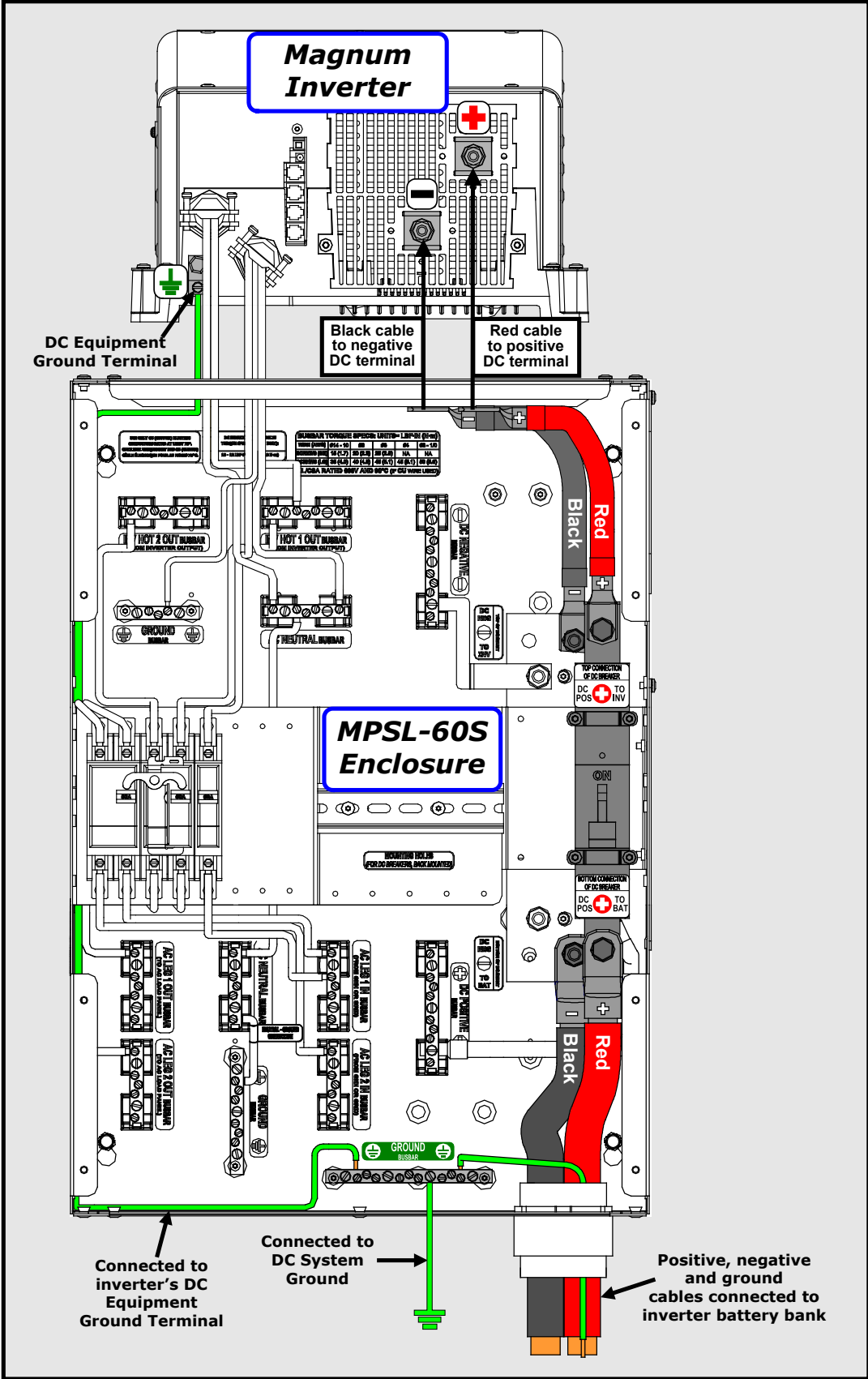

Figure 4-4c, MP5L-60S DC Wiring

4.0 Wiring Diagrams

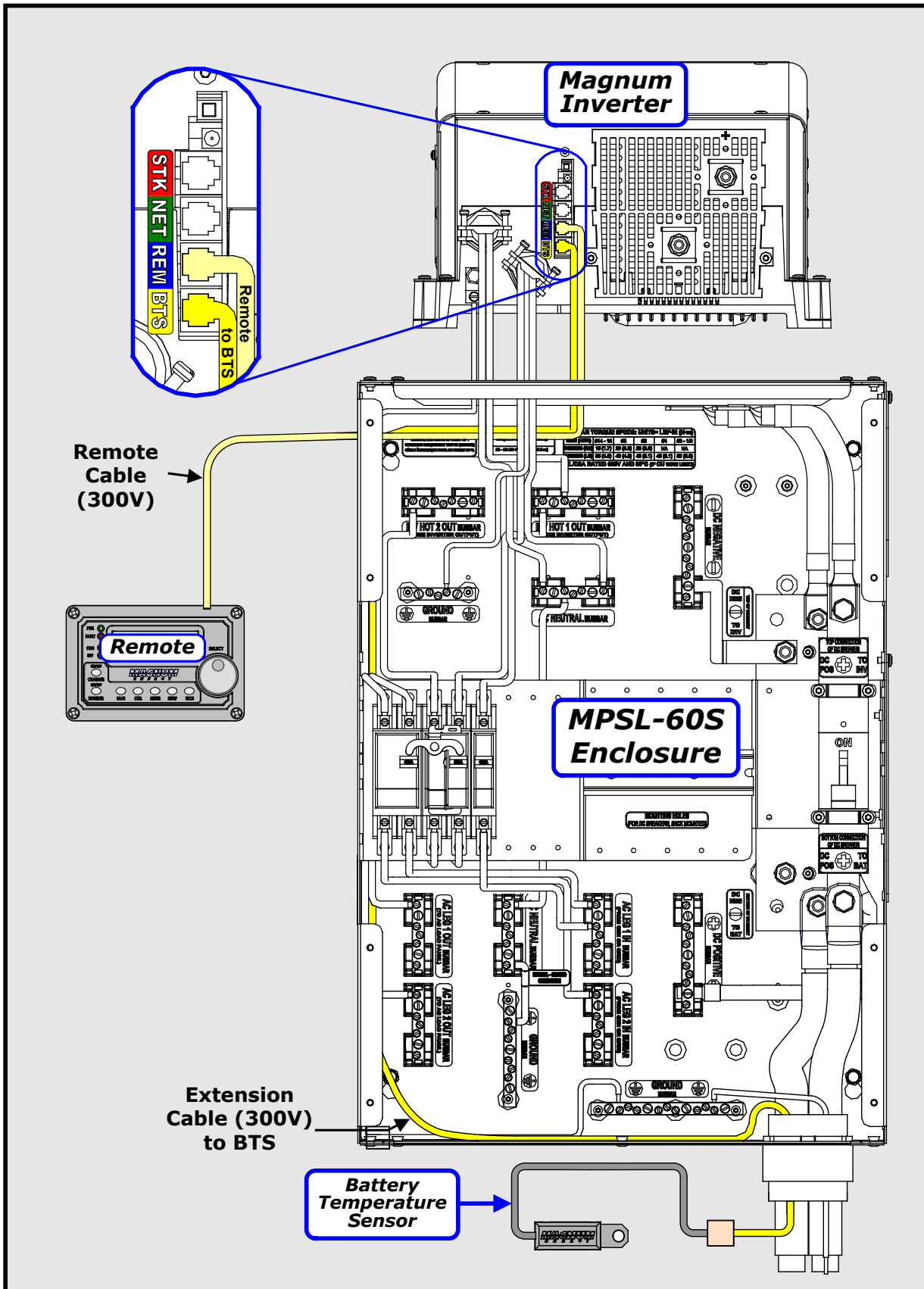

Figure 4-4d, MPSL-60S Communications Wiring

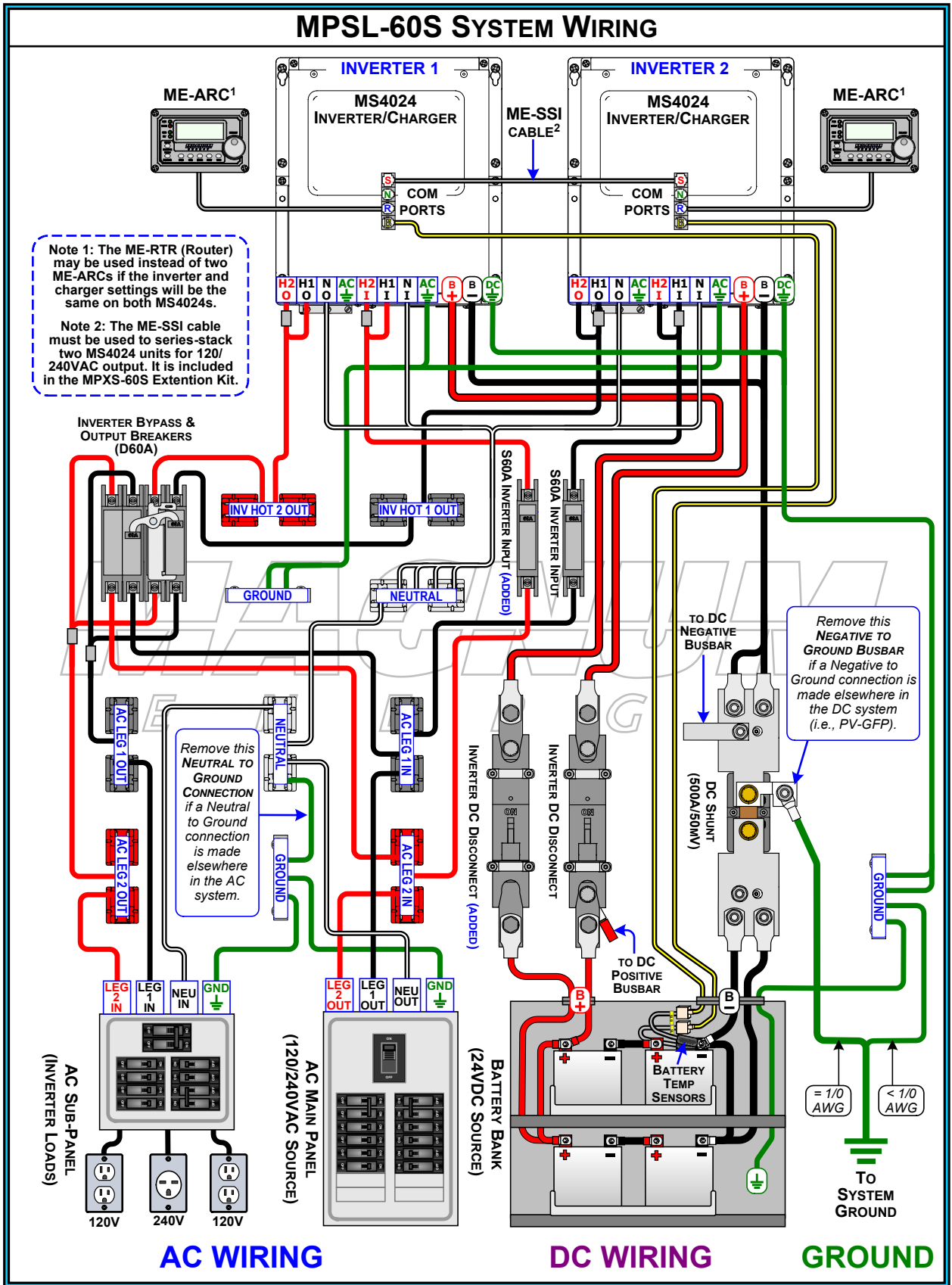

Figure 4-4e, MPSL-60S Full System Wiring Diagram

4.0 Wiring Diagrams

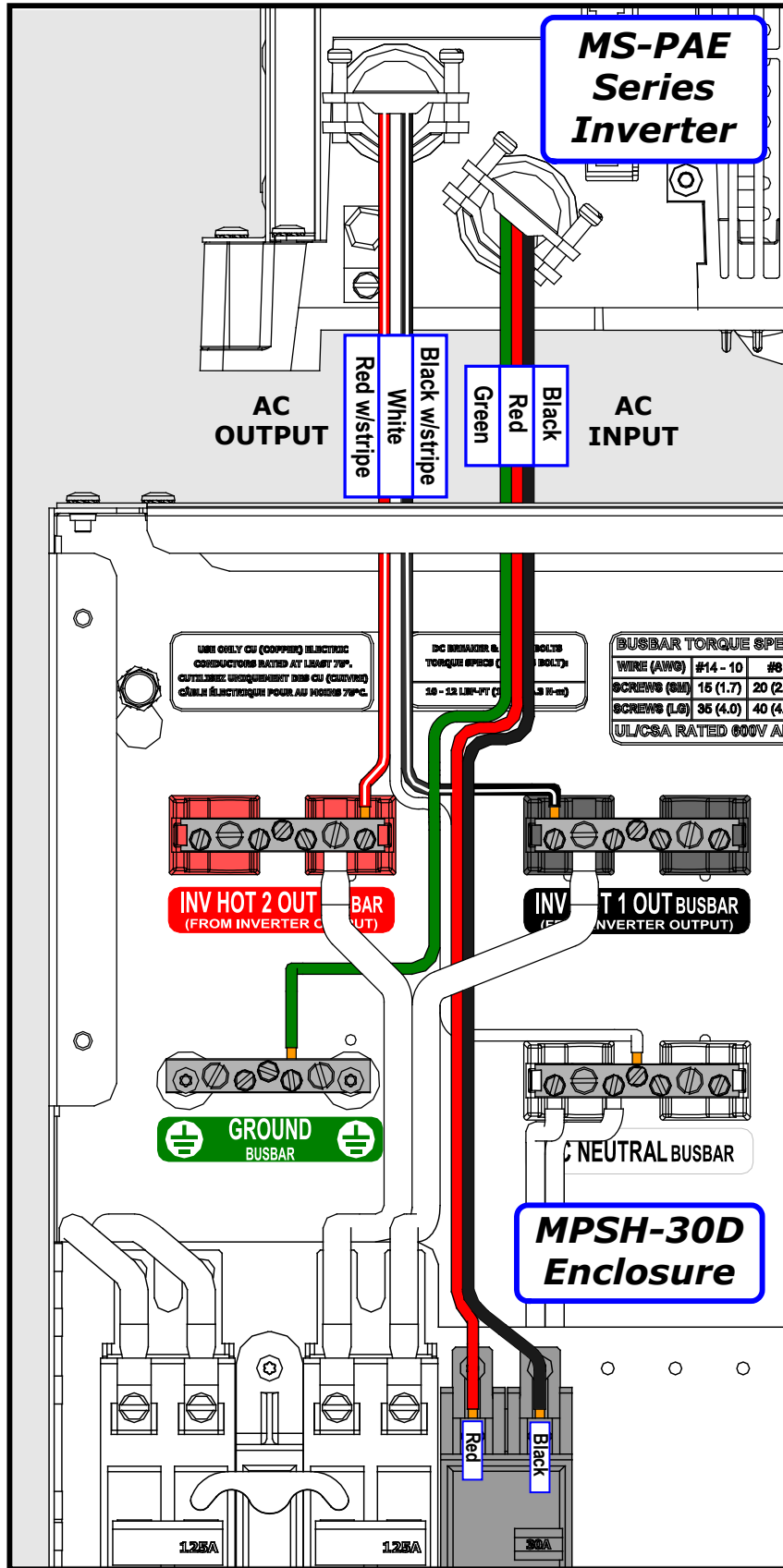

Figure 4-5a, MPSH-30D Inverter AC Wiring

Note: The NEUTRAL-GROUND CONNECTION wire must be removed if a neutral to ground connection is made in the AC Main panel (see section 3.9)

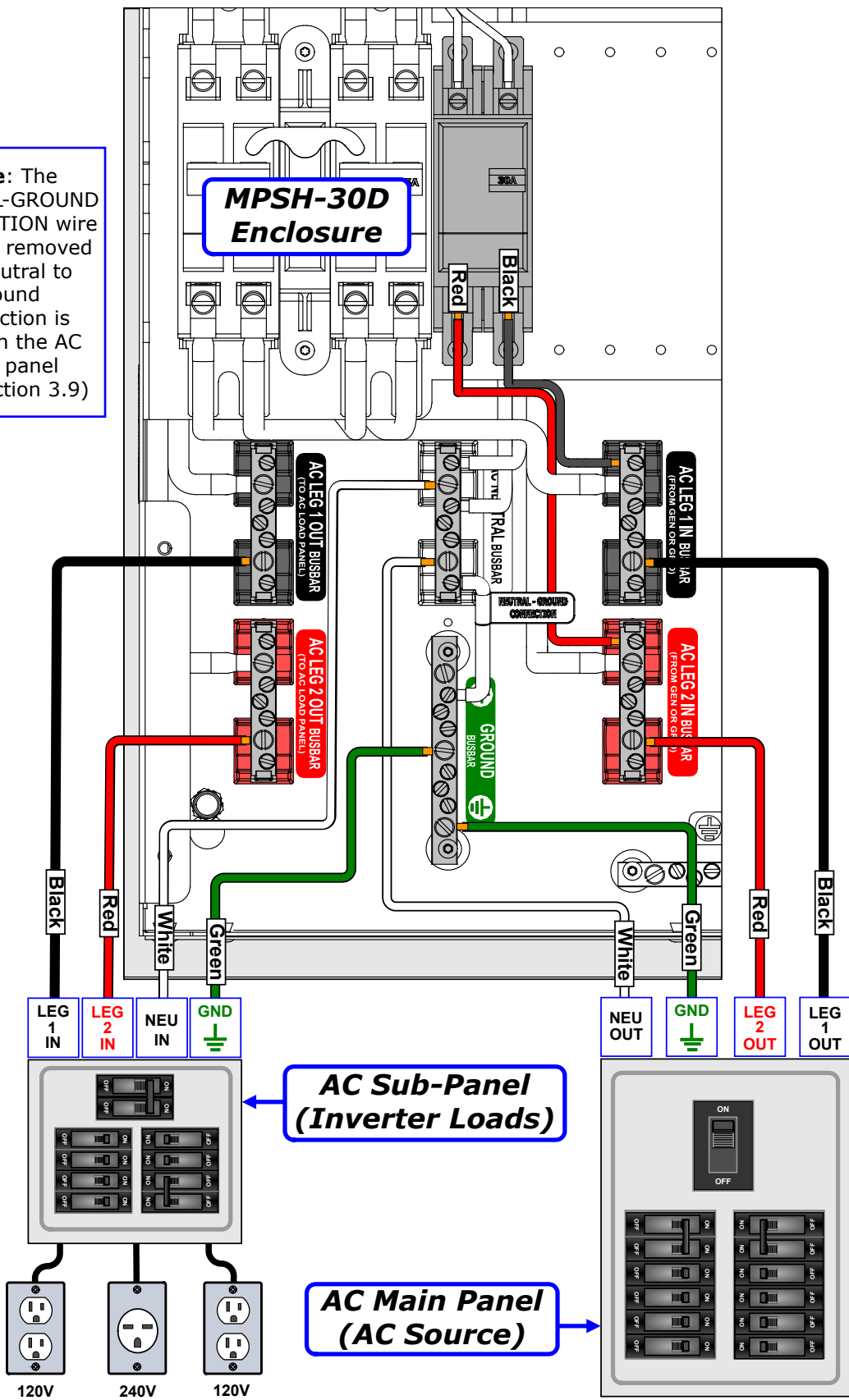

Figure 4-5b, MPSH-30D External AC Wiring

4.0 Wiring Diagrams

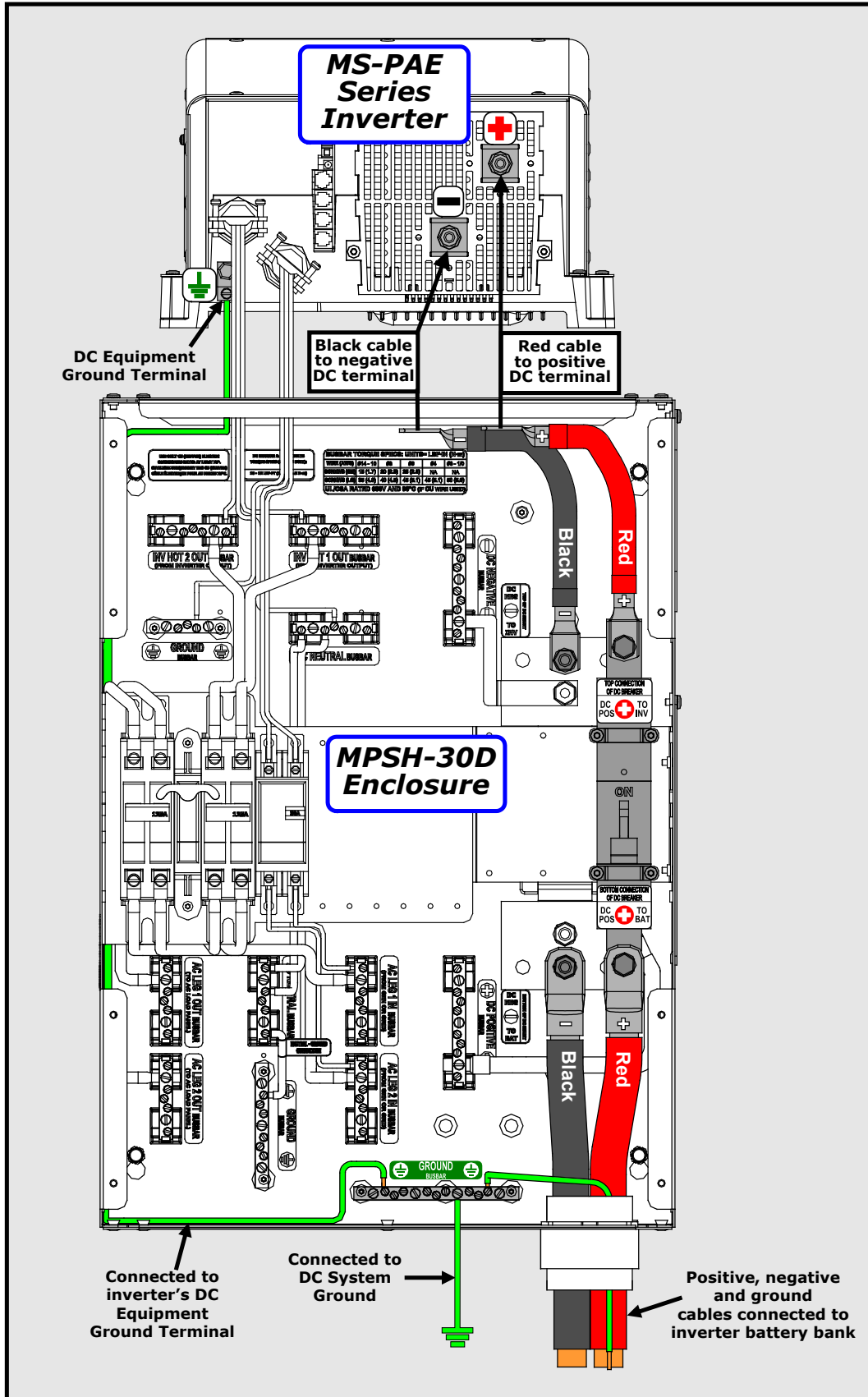

Figure 4-5c, MESH-30D DC Wiring

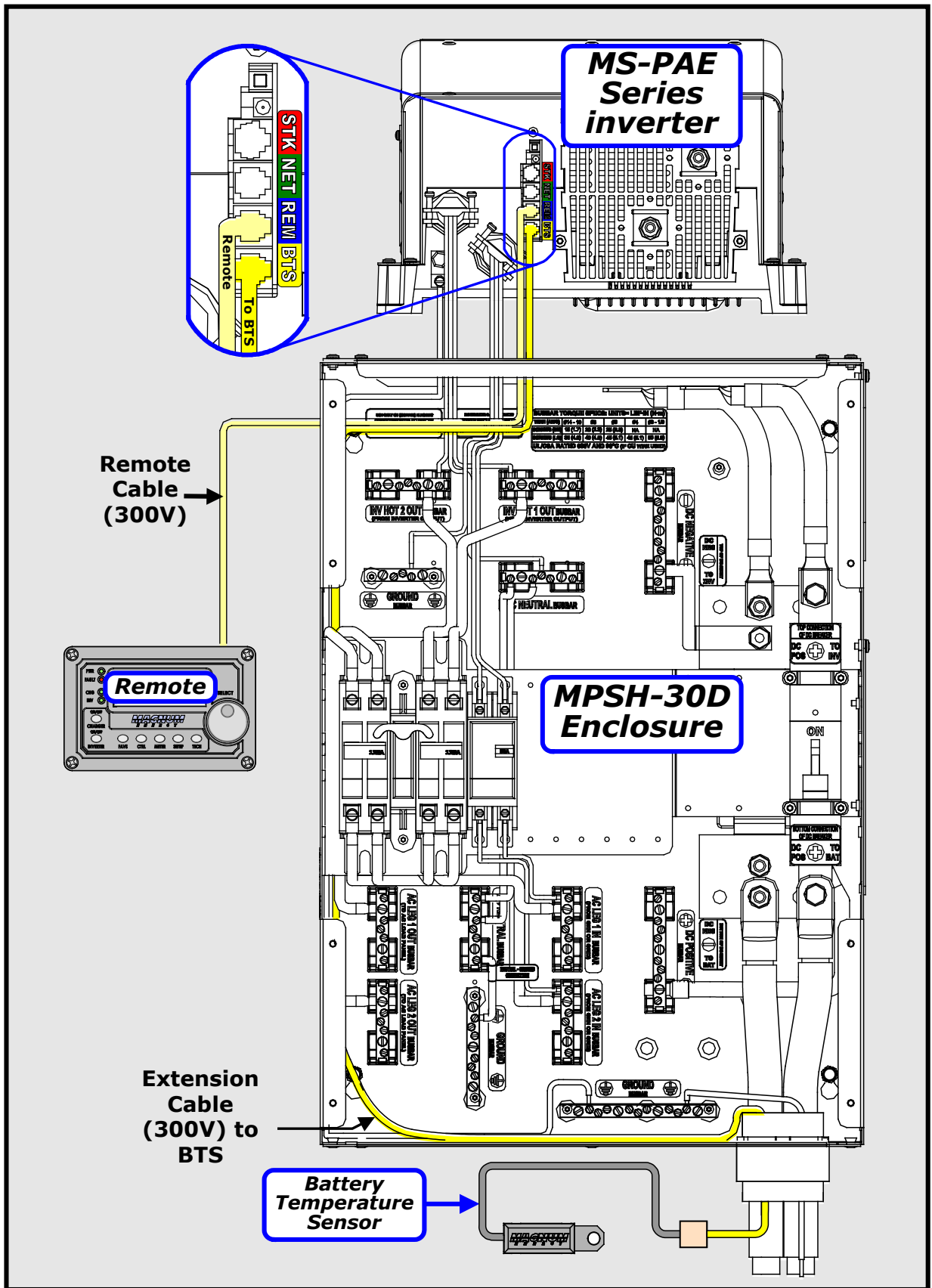

Figure 4-5d, MESH-30D Communications Wiring

4.0 Wiring Diagrams

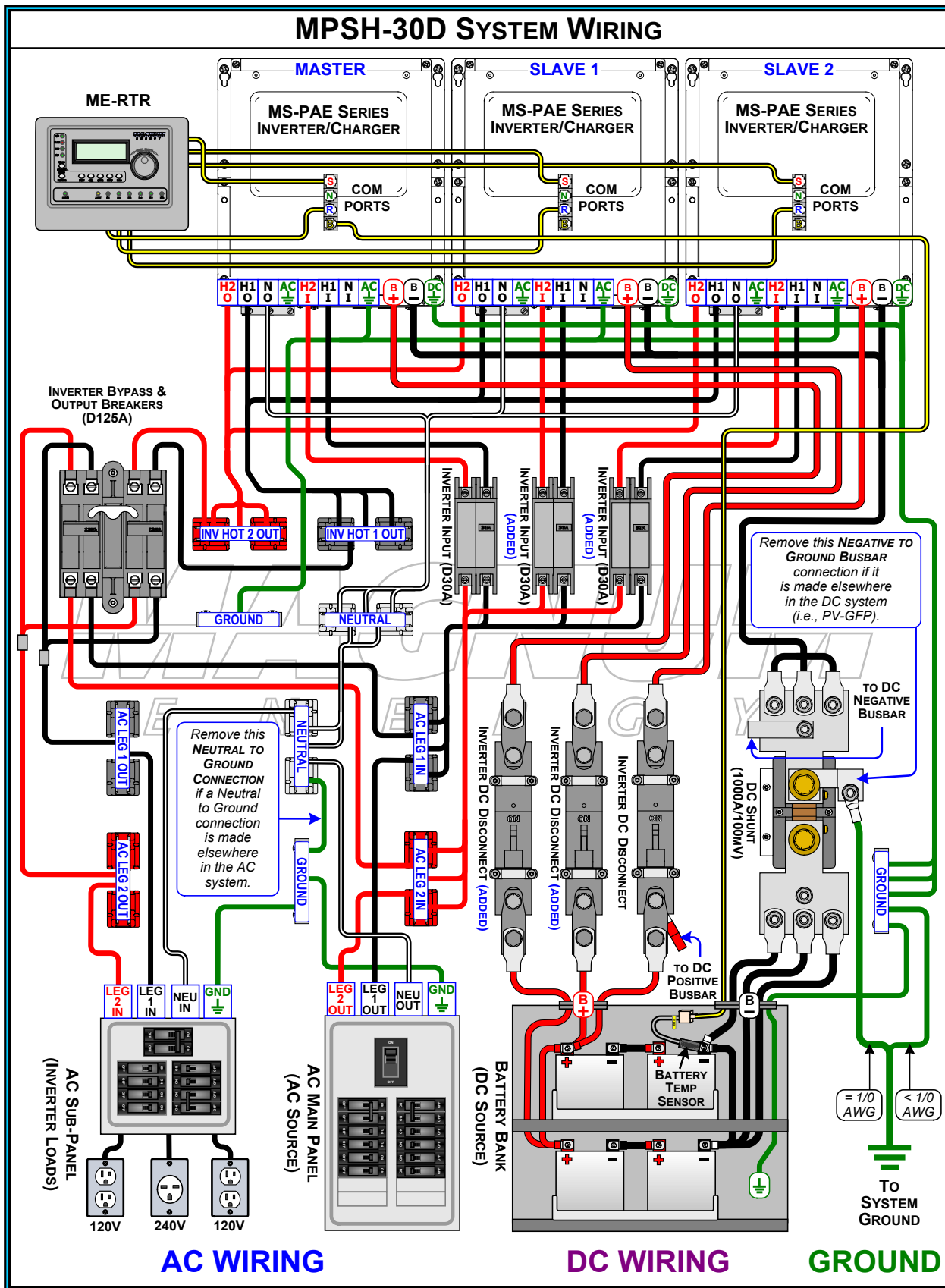

Figure 4-5e, MPSH-30D Full System Wiring Diagram

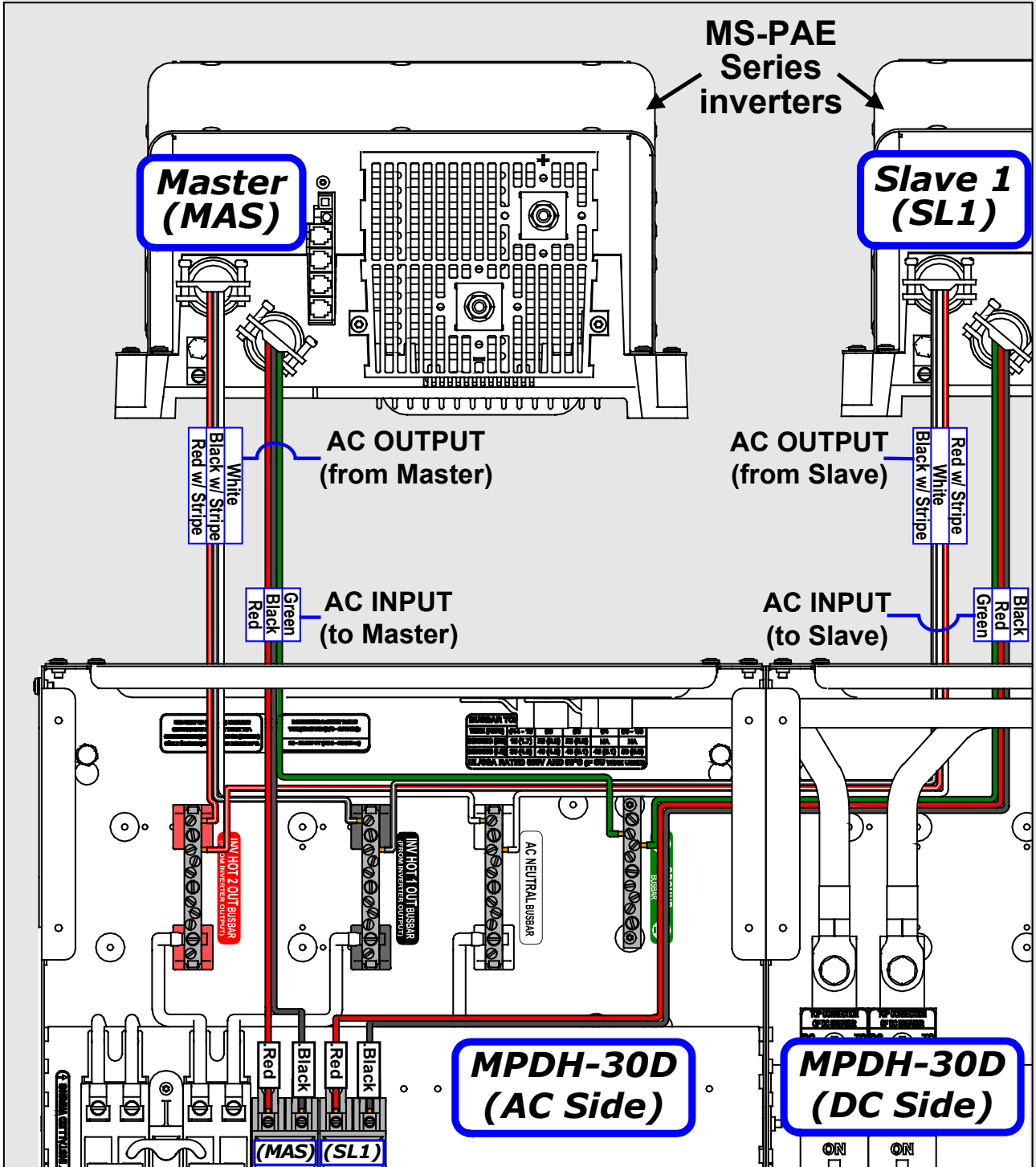

Figure 4-6a, MPDH-30D Inverter AC Wiring

4.0 Wiring Diagrams

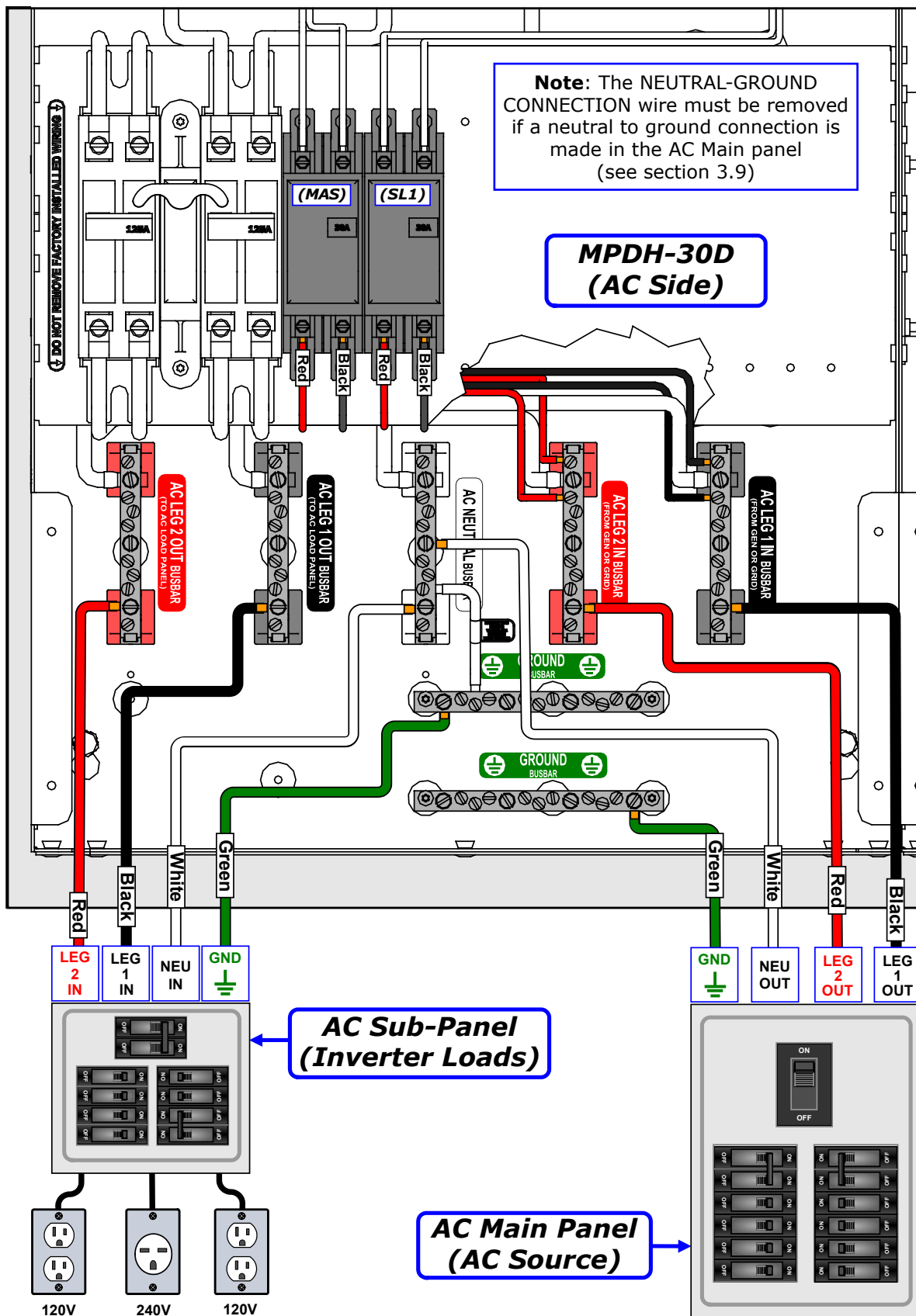

Figure 4-6b, MPDH-30D External AC Wiring

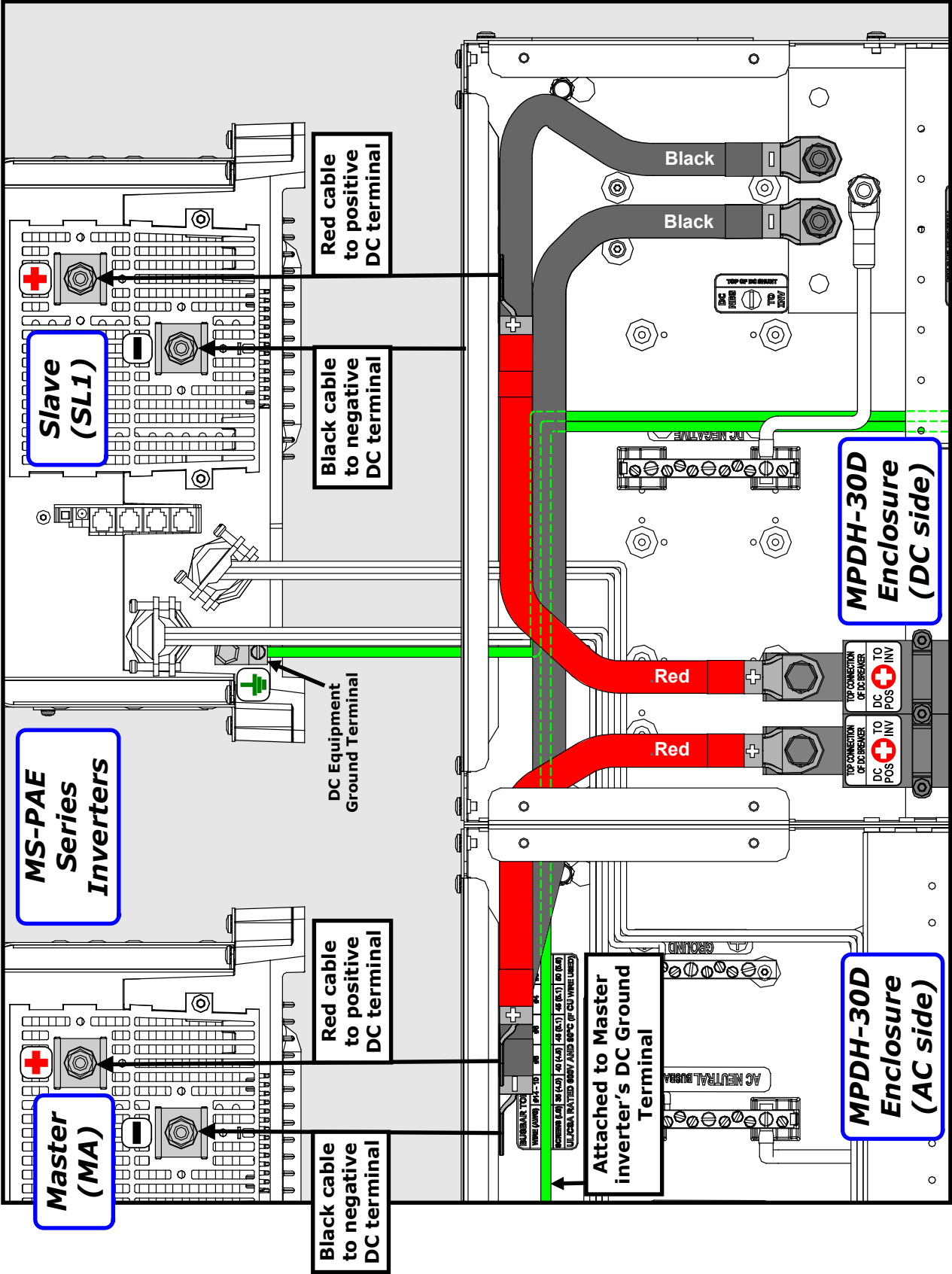

Figure 4-6c, MPDH-30D Inverter DC Wiring

4.0 Wiring Diagrams

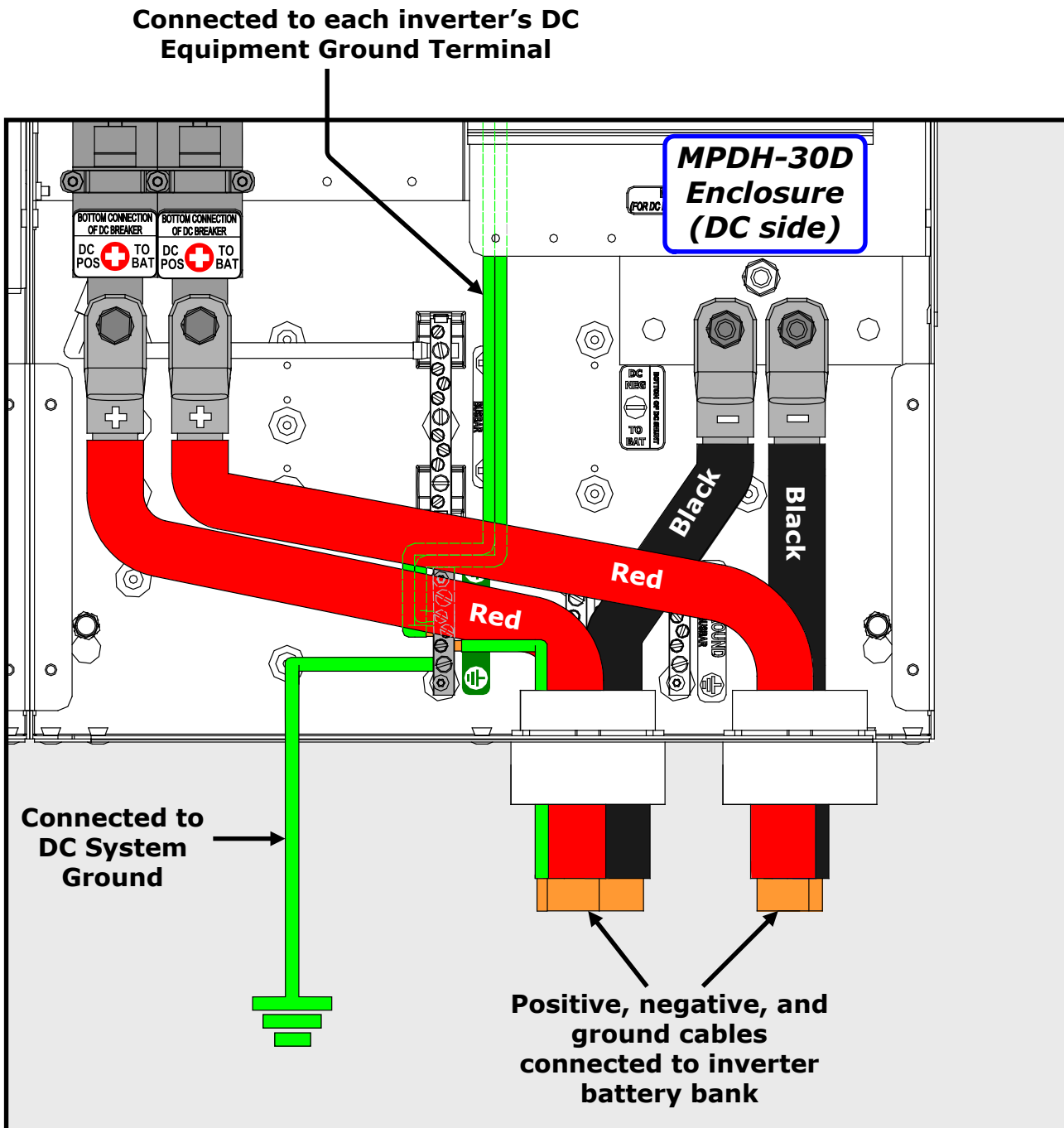

Figure 4-6d, MPDH-30D External DC Wiring

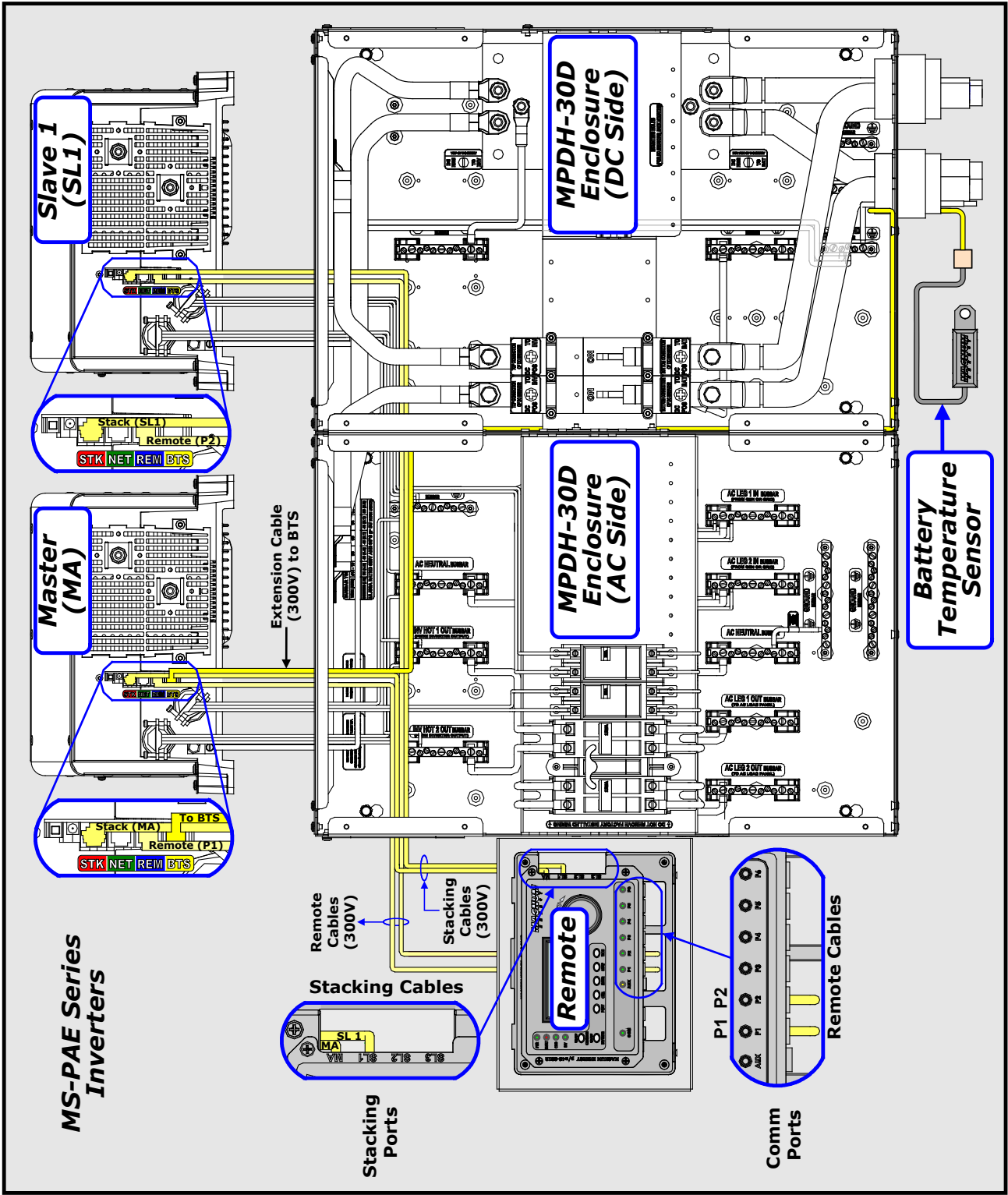

Figure 4-6e, MPDH-30D Communications Wiring

4.0 Wiring Diagrams

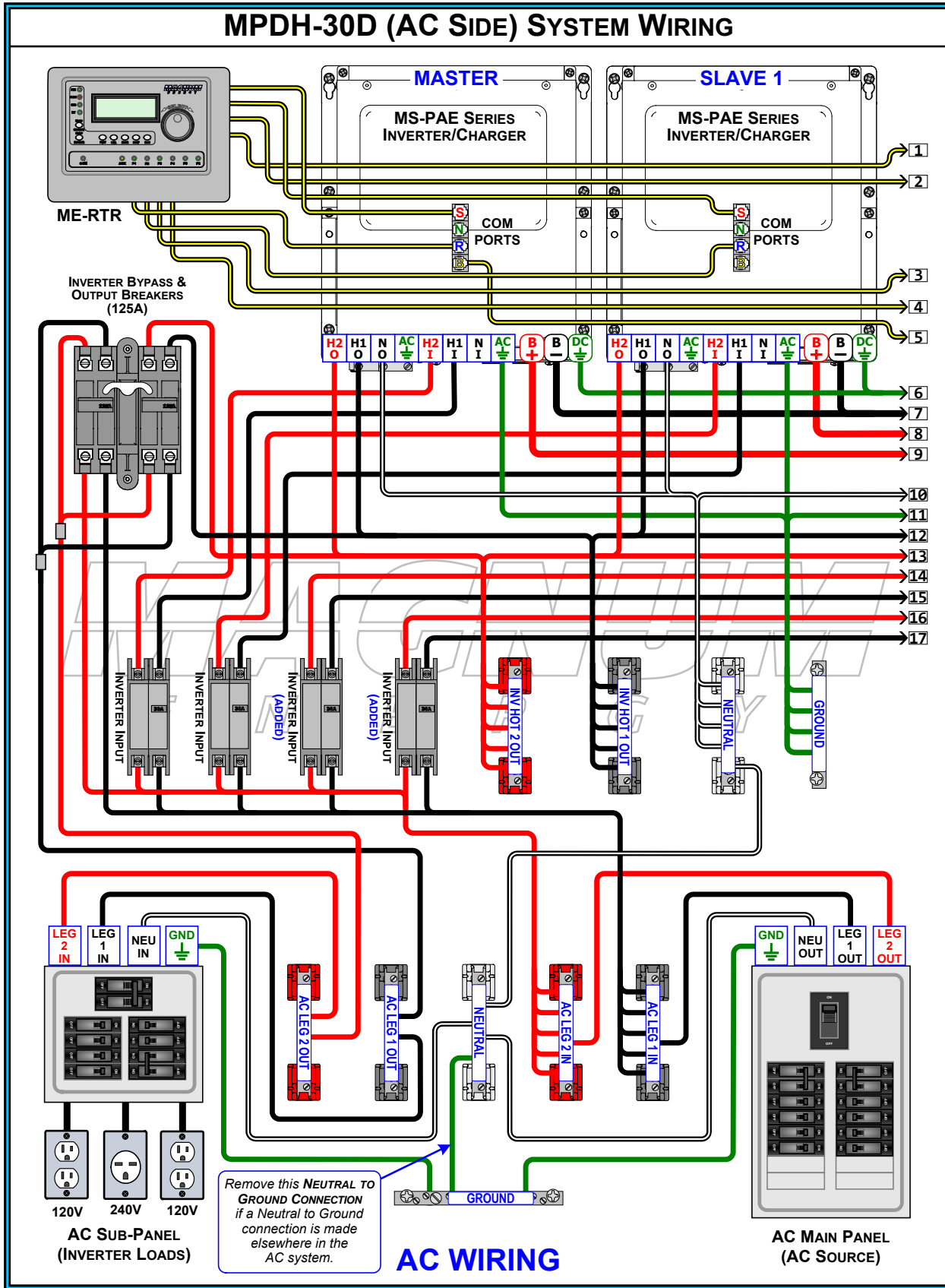

Figure 4-6f.1, MPDH-30D Full System Wiring Diagram (AC Side)

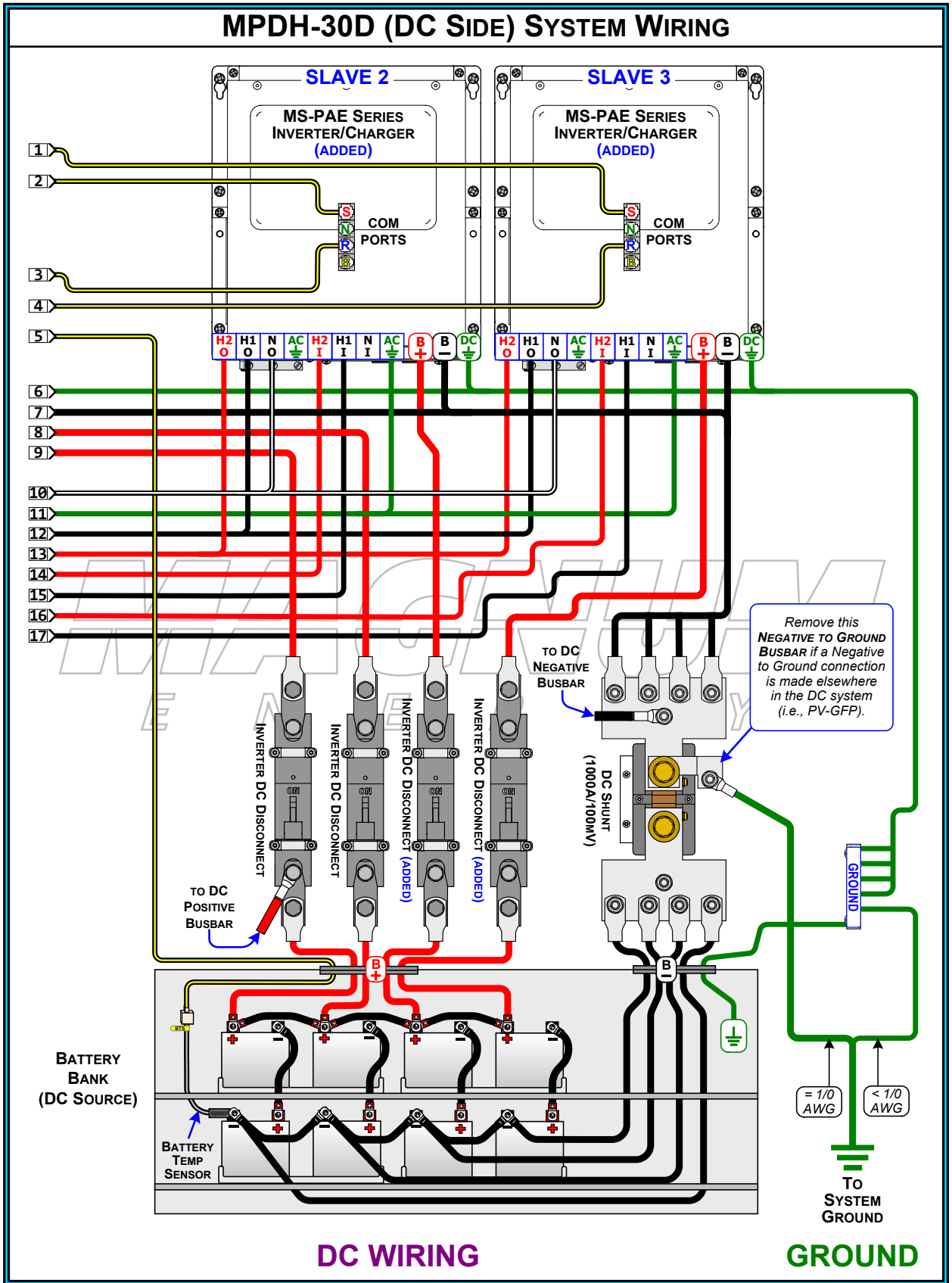

Figure 4-6f.2, MPDH-30D Full System Wiring Diagram (DC Side)

5.0 Operation

5.0 Operation

The MP enclosure provides you with circuit breakers/disconnects to easily operate and maintain your inverter/battery system. These breakers are used as the main power disconnecting means and/or overcurrent protection. Refer to Figure 5-1 to view a simple diagram of the functional operation of the breakers within the MP enclosure.



Info: Figure 5-1 is for descriptive purposes only, for specific wiring directions please refer to the relevant wiring diagram in the Installation section of this manual.



Info: For information on operating the inverter, refer to its owner's manual.

If a short-circuit condition occurs, or if a load is placed on the circuit breaker that is more than its rated capacity, the breaker will trip OFF (down). On the AC breakers, a red indicator will display through the clear window on the circuit breaker to show a tripped condition. On the other circuit breakers, the handle will trip all the way to the OFF position.

Before resetting the breaker, first determine the cause of the overcurrent fault. Then, reset the circuit breaker by turning it all the way OFF, and then all the way back ON. For proper maintenance and longer life, the circuit breakers should be turned off and on several times at least once a year. This will help to prevent the contacts inside from sticking together.

To shut the MP/inverter system OFF completely, all of the circuit breakers in the MP enclosure must be switched to the OFF position.

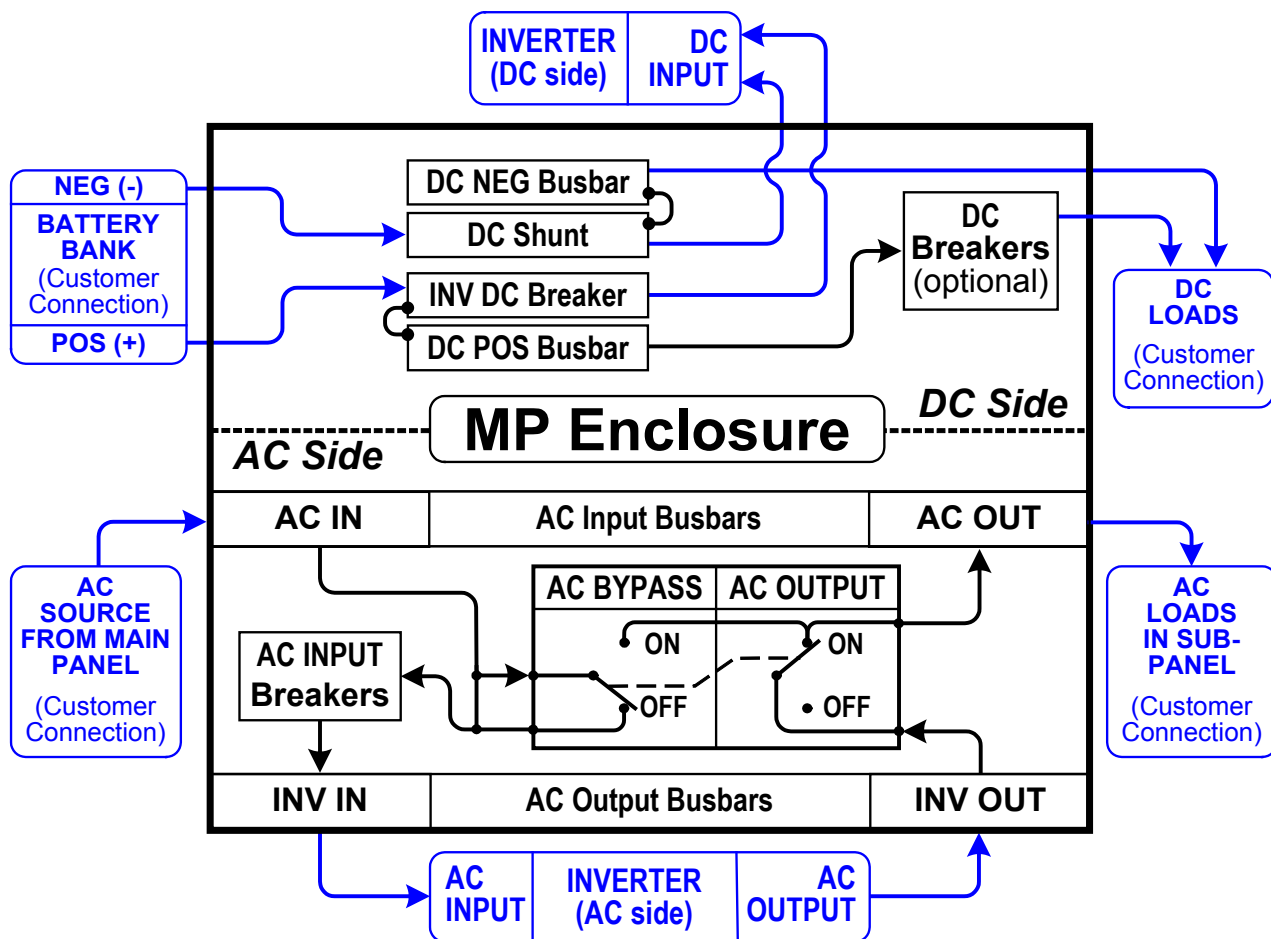

Figure 5-1, MP Functional Diagram

5.1 Inverter DC Disconnect Breaker

The Inverter DC Disconnect Breaker(s) is used to disconnect the battery during battery maintenance. This disconnect can also be used to protect the inverter, battery, and inverter DC cables from overloads and short circuits. The inverter DC disconnect does not, however, disconnect the battery power from the positive DC busbar in the MP enclosure. So, if you have installed any optional DC load breakers, you must turn OFF the DC load breakers to disconnect battery power to the DC loads.

Before switching the inverter DC disconnect(s) OFF, turn all inverters OFF. This is to protect the inverter and other equipment from failure, and to preserve the breaker contacts.



WARNING: Do not use the inverter DC disconnect breaker to turn your inverter on and off on a regular basis, it is there to provide safety and ease of maintenance. Turn off the inverter at its on/off switch first. However, in an emergency, the inverter DC disconnect is provided so that you can switch it off while the inverter is operating.



Info: Always switch the inverter DC disconnect to OFF before connecting or disconnecting the battery bank, to reduce the chance of spark and wear on the connectors.

5.2 Inverter AC Input Breaker

The Inverter AC Input Breaker when switched ON, allows the incoming AC source (generator or grid) to be connected to the inverter's AC input. This breaker should be switched OFF to disconnect the AC power from the inverter AC input.

On MP5L-30D, MP5H-30D and MP5D-30D models, this breaker is a double-pole 30 amp AC circuit breaker. On MP5L-60S models, this breaker is a single-pole 60 amp AC breaker.

5.3 Bypass Switch Assembly

The Bypass Switch Assembly consists of the AC output breaker and the inverter bypass breaker, and is pre-wired in the MP enclosure between the incoming AC source and the inverter load panel (i.e., sub-panel). The AC output breaker is mechanically interlocked with the inverter bypass breaker to prevent both breakers from being switched ON at the same time, but both can be switched OFF at the same time. The breaker assembly consists of two double-pole 60 amp AC circuit breakers on MP5L-30D and MP5L-60S models, and two double-pole 125 amp AC circuit breakers on MP5H-30D and MP5D-30D models.

Refer to Figure 5-2 (60A Bypass) or Figure 5-3 (125A Bypass) to review the operational modes and power flow of the bypass switch assembly.

5.3.1 AC Output Breaker

The AC Output Breaker when switched ON, allows the AC power of the MP/inverter system — either the total inverter power or pass-thru power (generator or grid) — to be connected to the AC loads. With this breaker OFF, the AC loads connected to the output of the MP enclosure are disconnected from power and can be serviced.

5.3.2 Inverter Bypass Breaker

The Inverter Bypass Breaker allows the inverter loads to continue to be powered by the incoming AC source (generator or grid) if the inverter or battery bank system needs to be serviced/disconnected — without any re-wiring.

The bypass breaker is normally set to OFF to allow the incoming AC source to be connected to the inverter's AC loads "through the inverter". It can easily be switched ON to "bypass" the inverter and allow the AC loads to be powered by the incoming AC source directly.



Info: If possible, before switching the bypass breaker ON, turn off all AC loads so you are not switching the breakers under load — to reduce wear on the breaker contacts.



Info: When the bypass breaker is ON, the connected AC loads/equipment are directly powered from the AC source (generator or grid). If the incoming AC source is disconnected or turned off, the connected AC loads/equipment will also go off.

5.0 Operation

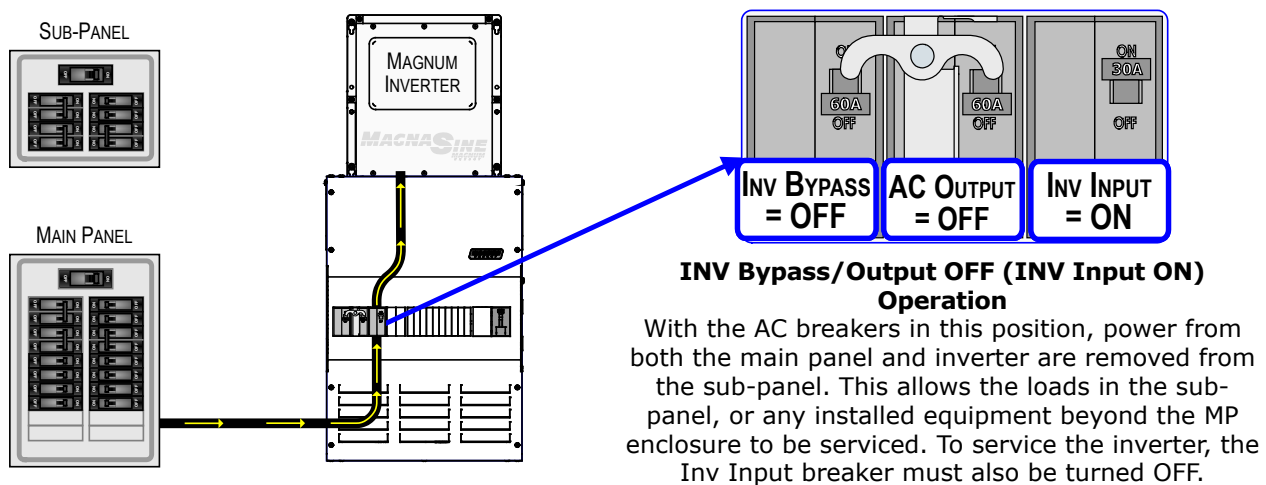
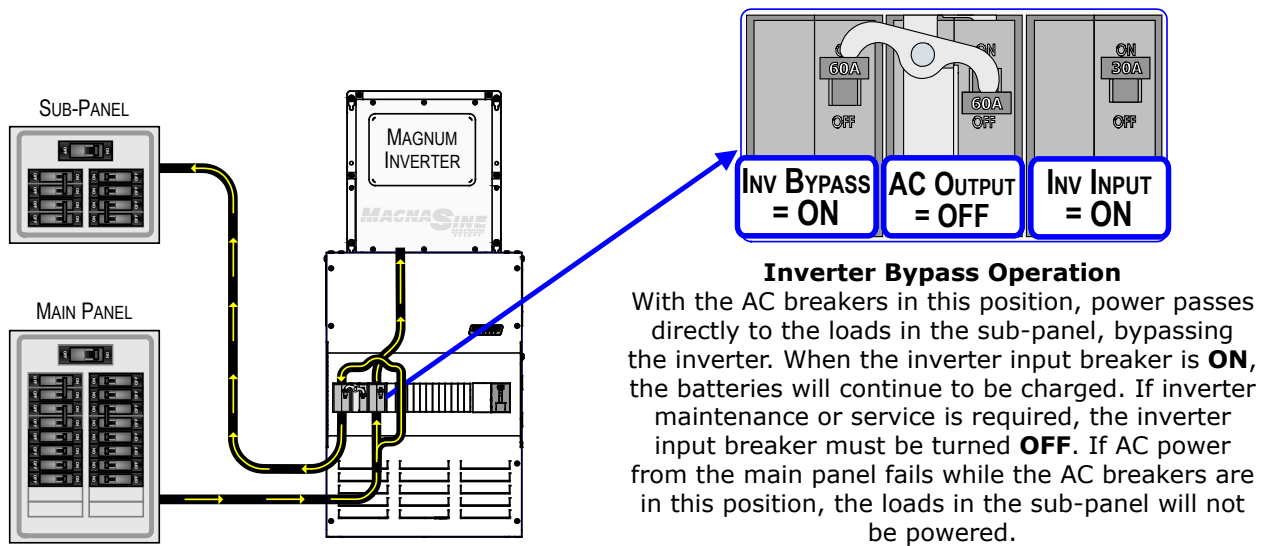
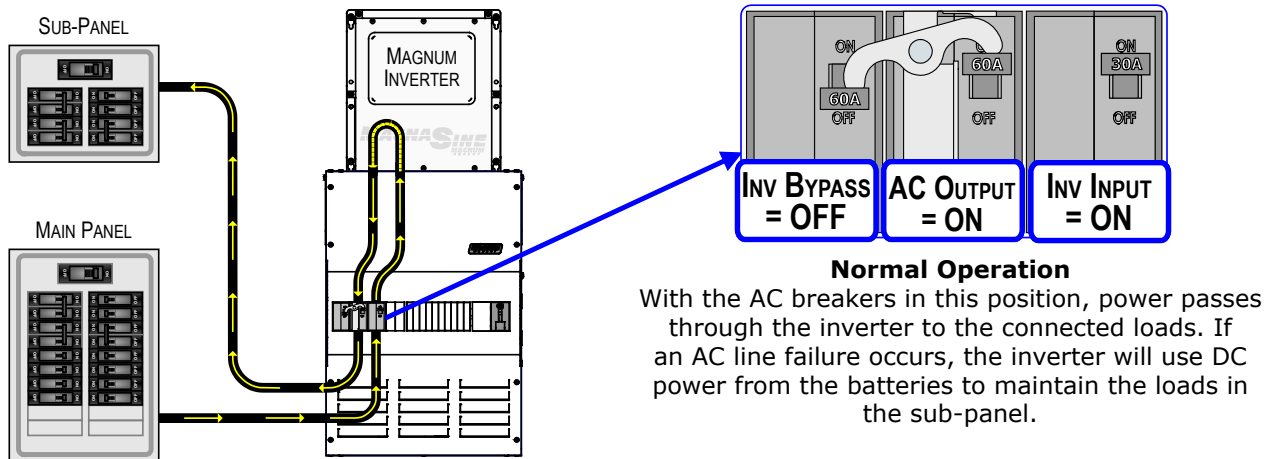

Note: The Inverter Input Breaker shown in this figure is a double-pole 30A breaker. On MPSL-60S models this breaker is a single-pole 60A breaker, however the operation of this breaker is the same as shown.

Figure 5-2, 60A Bypass Switch Operation (MPSL-30D and MPSL-60S)

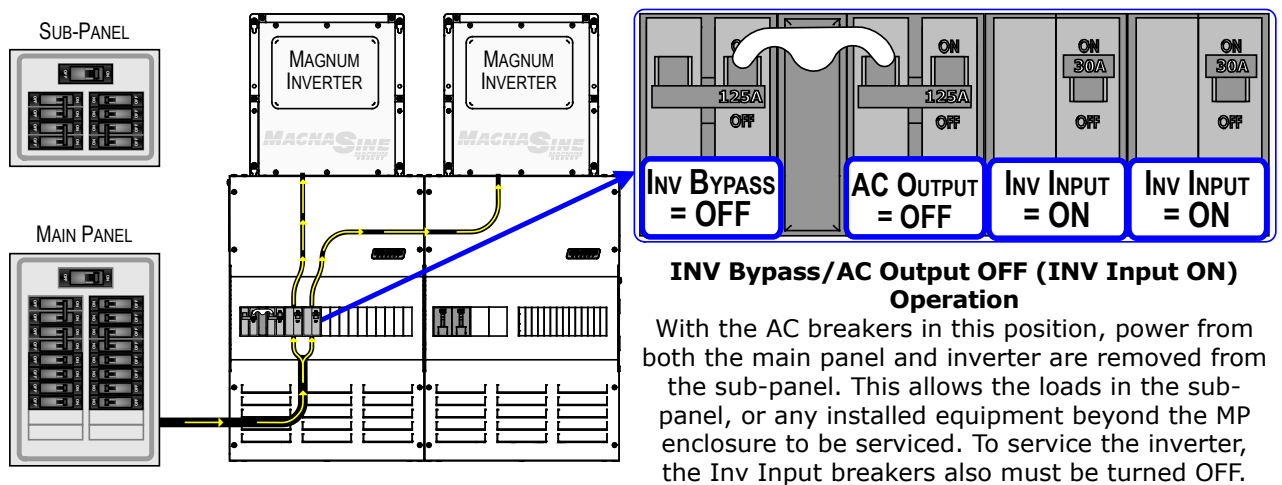
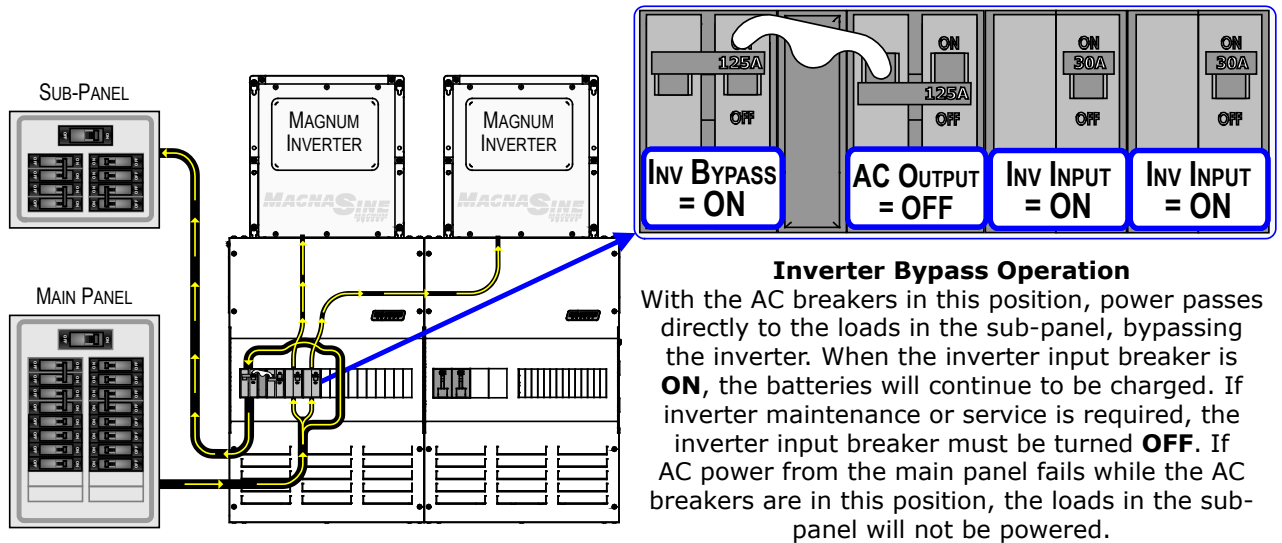
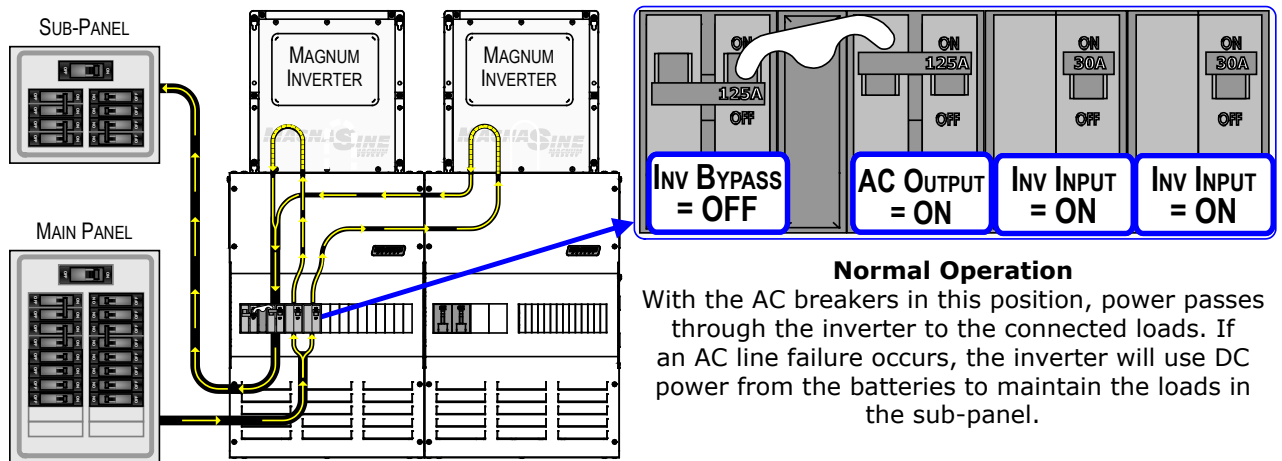

Figure 5-3, 125A Bypass Switch Operation (MPSH-30D and MPDH-30D)

Appendix A - Optional Equipment and Accessories

Appendix A - Misc. Info and Optional Equipment/Accessories

A1 Installing the Charge Controller Bracket

A Charge Controller Bracket is provided to mount the most commonly used charge controllers to the MP enclosure. This bracket can be easily mounted on either the left or right side of the MP enclosure, and is designed to work with specific MidNite, MorningStar, or OutBack charge controllers.



Info: The necessary hardware is provided to secure the bracket to an enclosure, and to mount a charge controller to the bracket is provided (see Figure A1-1).

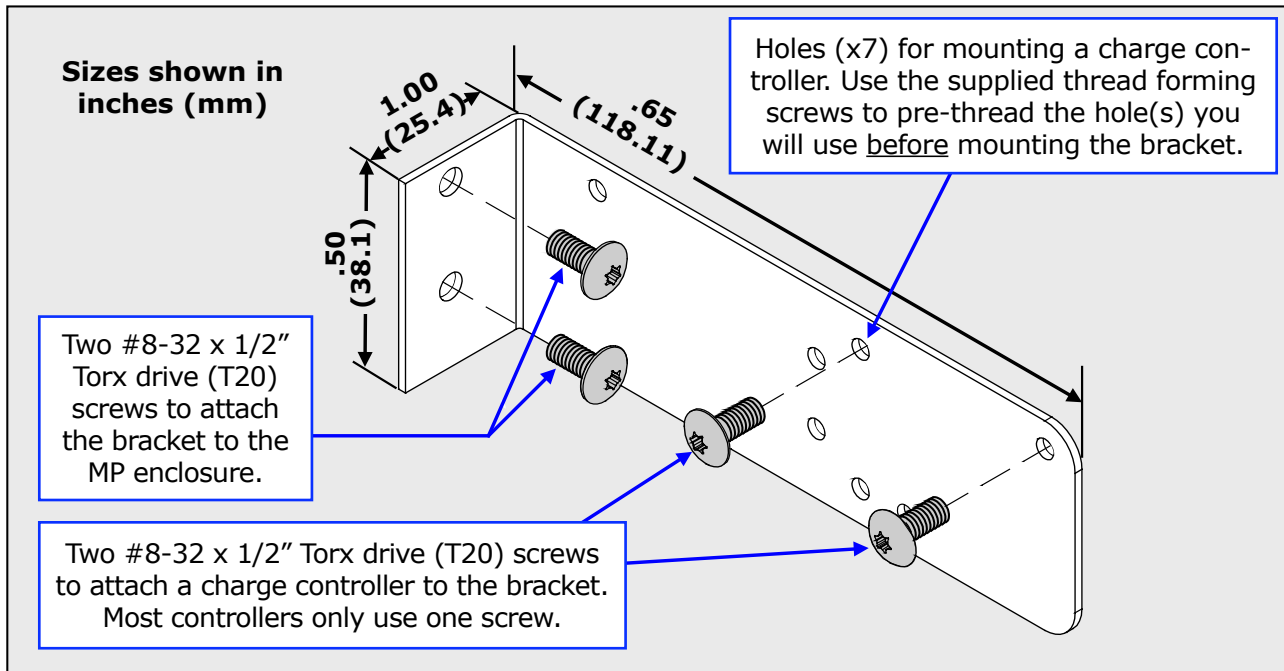

Figure A1-1, Charge Controller Bracket - Physical Dimensions

Installation

Before proceeding, use Table A-1 to determine the following for your particular charge controller:

- which side of the enclosure (left or right) to mount the controller,
- which enclosure mounting holes (upper or lower) are used to attach the bracket,
- which bracket hole(s) (A-G) are used to attach the controller.

Table A-1, Mounting Holes Used for Charge Controllers

Charge Controller	Holes to use: (Bracket) / [Enclosure]	
	Left Side Install	Right Side Install
Classic w/o Turbo (MN)	(B) / [upper]	(F) / [upper]
Classic w/Turbo (MN)	(A) / [upper]	(F) / [upper]
FlexMax 80 (OB) ¹	NA	(G) and (E) / [upper]
Tristar (MS)	(D) / [lower]	(C) / [lower]

(MN) = MidNite, (OB) = OutBack, (MS) = MorningStar

Note 1 - The FlexMax 80 is taller than most controllers and may not fit if something is mounted above it. If an MPX extension is to be installed on an MP enclosure, if possible mount the MPX extension on the left side to allow the FlexMax 80 to be mounted on the right hand side.

Appendix A - Optional Equipment and Accessories

Refer to Figure A1-2 to locate the holes you will use to attach the charge controller to the bracket. Before mounting the bracket, use the provided T20 Torx drive, thread forming screws to pre-thread your selected mounting holes. It is easier to thread the holes now rather than doing it after the bracket and controller have been installed.

After pre-threading your particular bracket hole(s), refer to Figure A1-3 to locate the enclosure mounting holes you will use to attach the bracket to the enclosure. Before you mount the charge controller to the attached bracket, remove the appropriate knockout from the side of the controller and an adjacent knockout on the side of the enclosure. This allows you to use a 1" close nipple with two locknuts to secure the charge controller to the enclosure (in addition to the bracket), and provides a path to run the necessary wiring between the two units. Mount the controller to the attached bracket using the supplied hardware. Insert the close nipple through the knockouts and secure with the locknuts.



Info: It may take three locknuts on the close nipple to anchor the controller to the enclosure. An additional locknut may be required between the enclosure and the controller to act as a spacer. Also, a standard 1" plastic bushing should be used on the nipple ends to protect the wire insulation as it enters/exits the nipple.

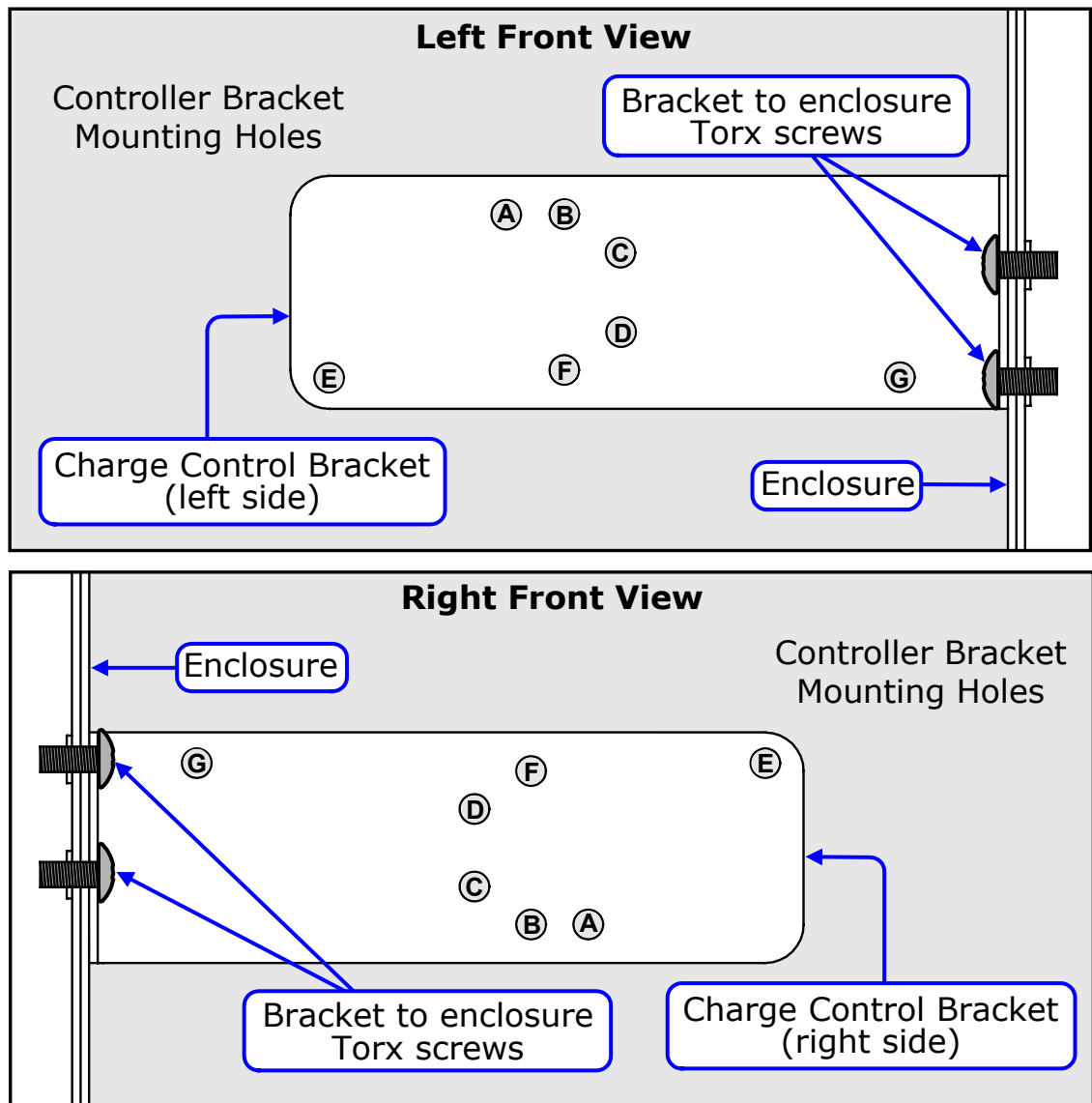

Figure A1-2, Charge Controller Bracket Mounting Holes

Appendix A - Optional Equipment and Accessories

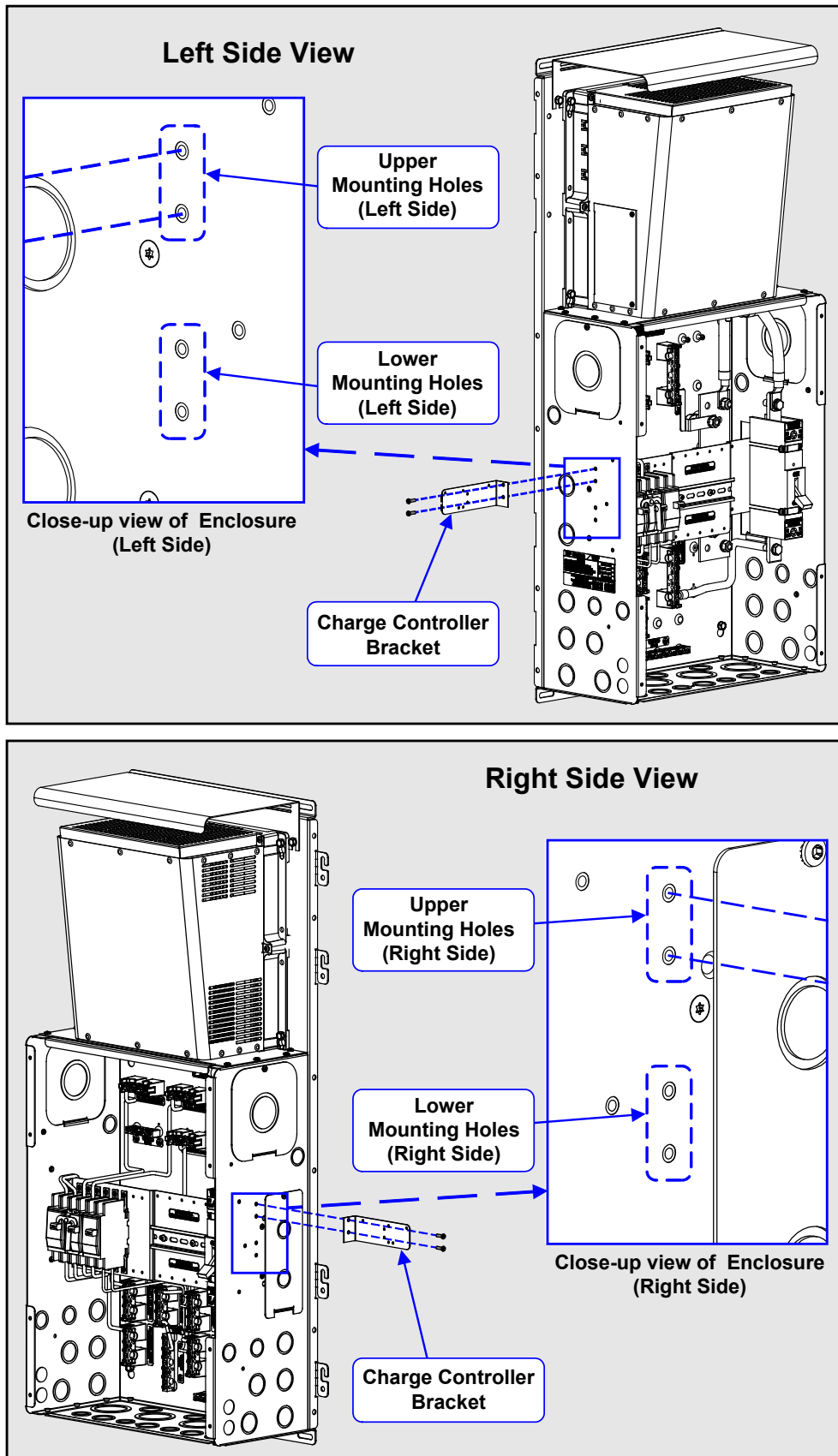

Figure A1-3, Holes Used to Mount Bracket on MP Enclosure

A2 Installing a Battery Monitor

Magnum Panels are factory equipped with a DC shunt (Item 31, Figure 2-7 and 2-8; Item 29 Figure 2-9; or Item 30, Figure 2-10b). This allows a battery monitor to be easily wired.

Magnum Energy's ME-BMK-NS (Battery Monitor Kit - No Shunt) is a battery bank amp-hour meter that provides important information about the condition of the battery bank. This information will let you know how much energy you have available, and let you plan your electrical usage to ensure the batteries are not being over-discharged. Using a Magnum remote/display, you will be able to see the percentage state of charge, real time amps, voltage, amp-hours in/out, and the minimum/maximum DC volts. The Battery Monitor Kit includes the sense module, sense wires and a network cable.

The MP enclosures provide two mounting dimples installed with #8-32 x 1/2" (T20 drive) Torx screws. This allows the sense module (part of the ME-BMK-NS) to be easily installed inside the MP enclosure (as shown in Figure A2-3). Once the sense module is installed, wire the sense wires and module to the DC shunt by removing the Shunt Access Plate on the right side of the MP enclosure. See Figure A2-2 and A2-4 for information on wiring the ME-BMK-NS.

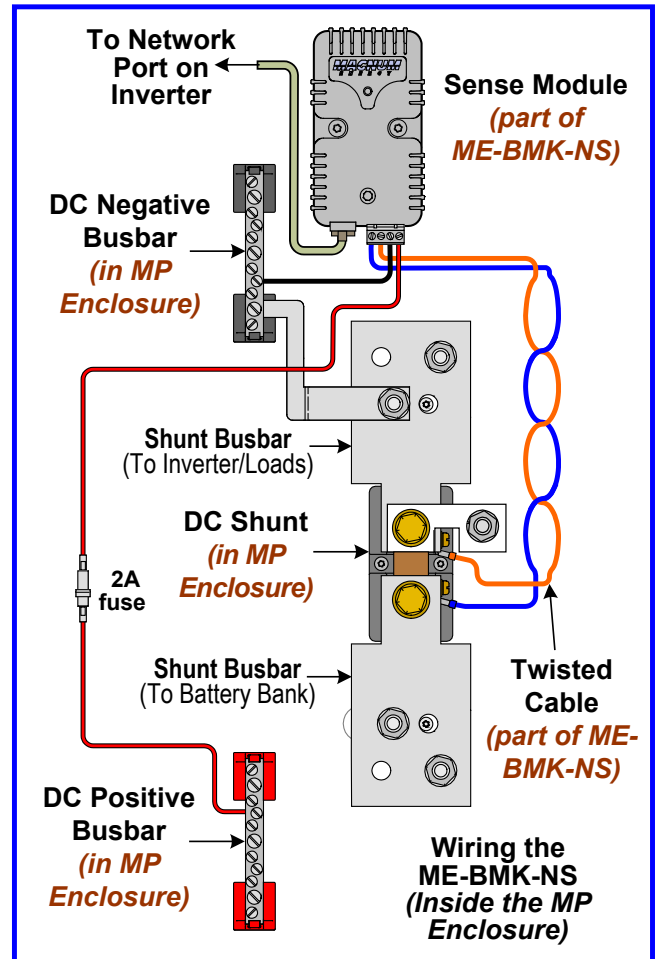
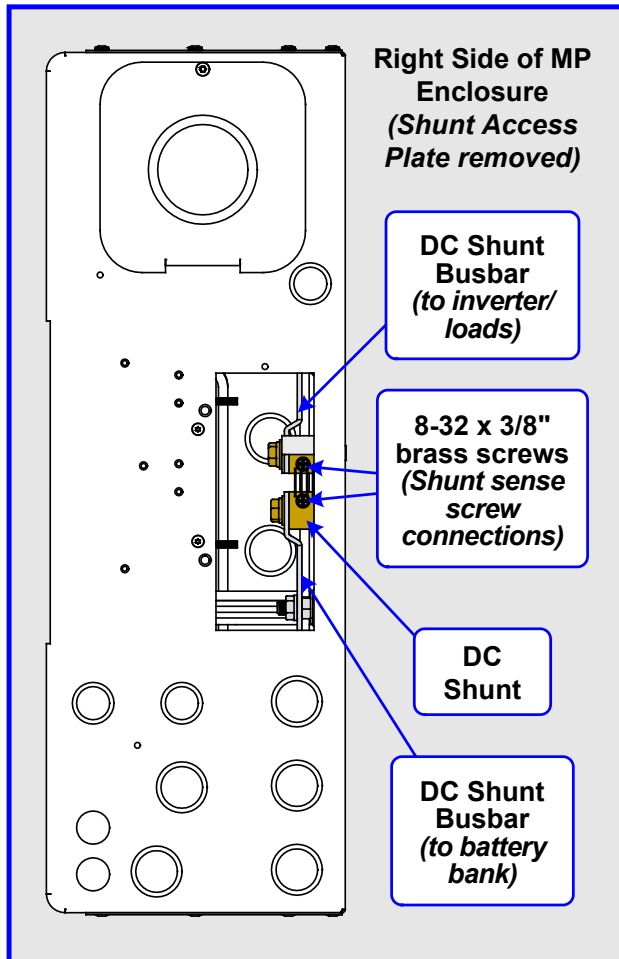

Figure A2-1, Accessing the DC Shunt

Figure A2-2, Wiring the ME-BMK-NS

Appendix A - Optional Equipment and Accessories

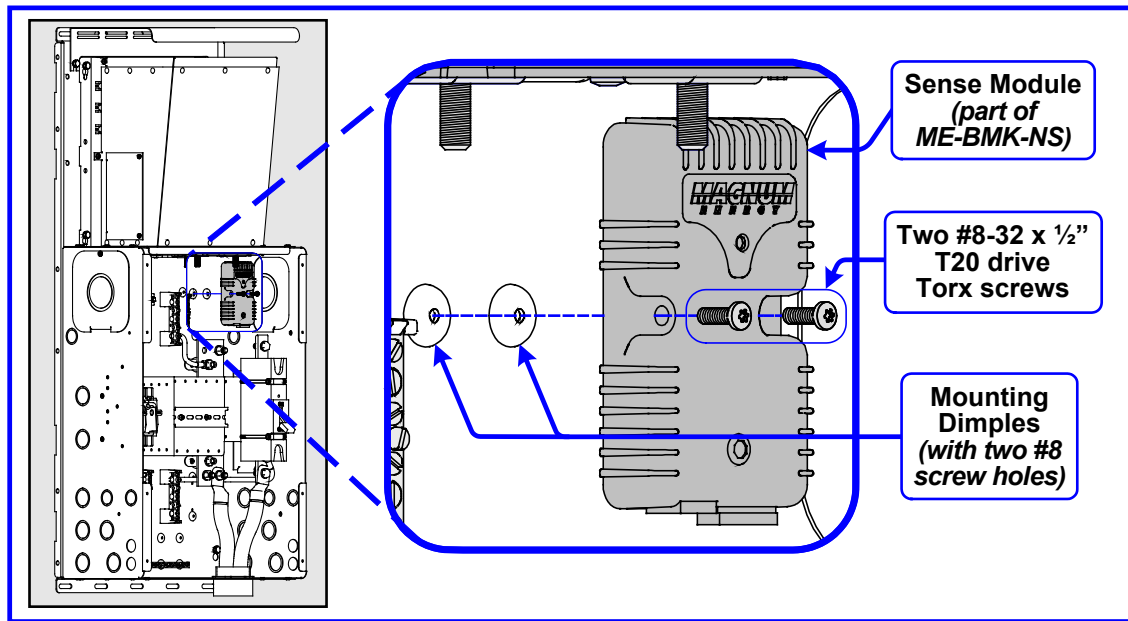

Figure A2-3, Mounting the Sense Module

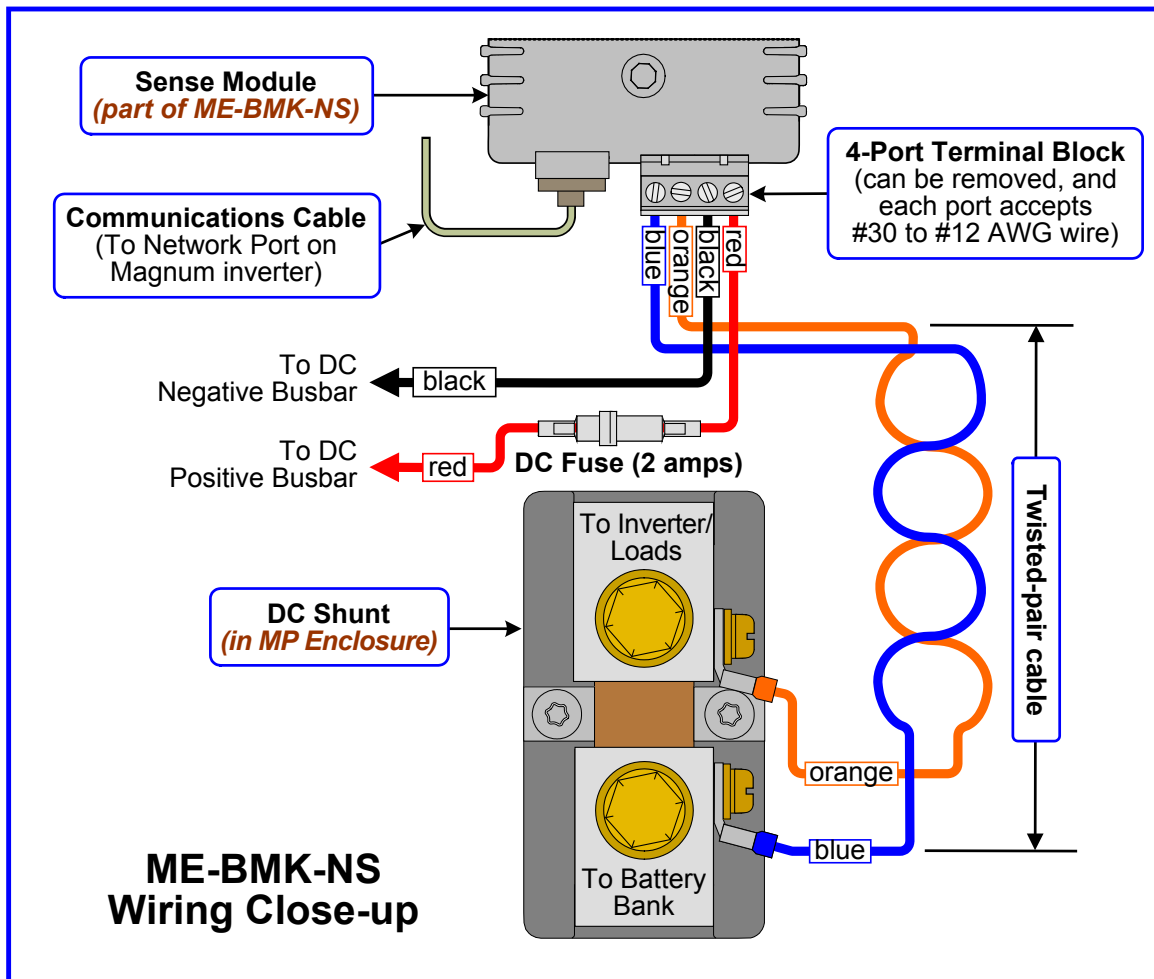

Figure A2-4, Close-up of Wiring the Sense Module and DC Shunt

A3 Inverter Hood Info

The inverter hood is a powder-coated steel cover plate, designed to prevent inverter damage from objects falling through the top vents of the inverter. The hood is required for installations when the inverters are mounted on a vertical surface (DC side down) - such as on the MP enclosure.



Info: The hood does not mount to the inverter chassis, it must be mounted against the wall. The mounting slots on the hood will accept up to a maximum 1/4 inch screw/bolt.



CAUTION: The hood is not to be used as a drip shield to prevent water drip from entering the inverter.

Installation Guidelines:

1. The bottom edge of the hood must be mounted flush against the top of the Magnum inverter; this is the optimal position for minimizing the risk of objects falling into the inverter, and at the same time providing the clearance needed for air flow from the top vents of the inverter.
2. Do not place anything on top of the hood that might cause it to bend downward; or, place anything on the sides to restrict air flow through the inverter.

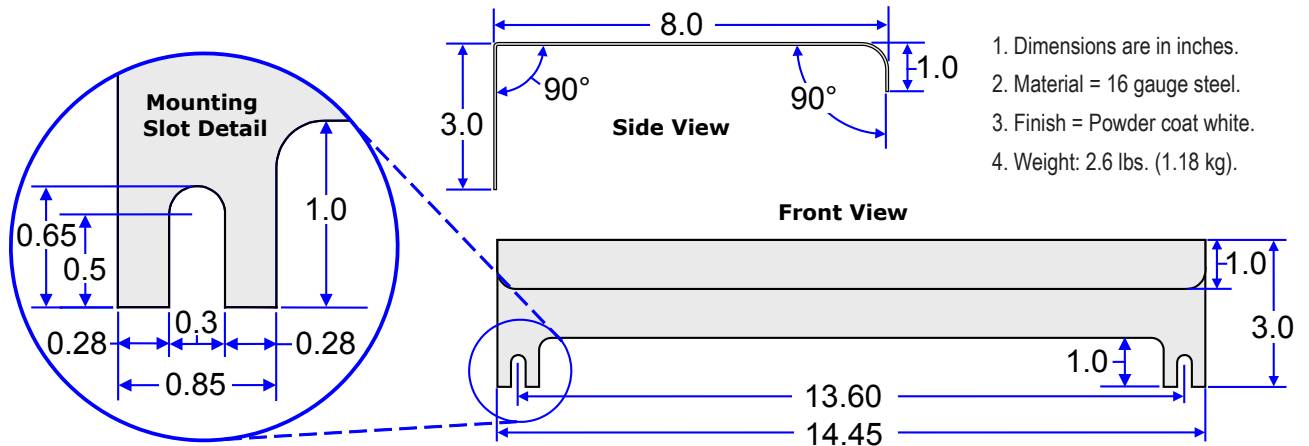
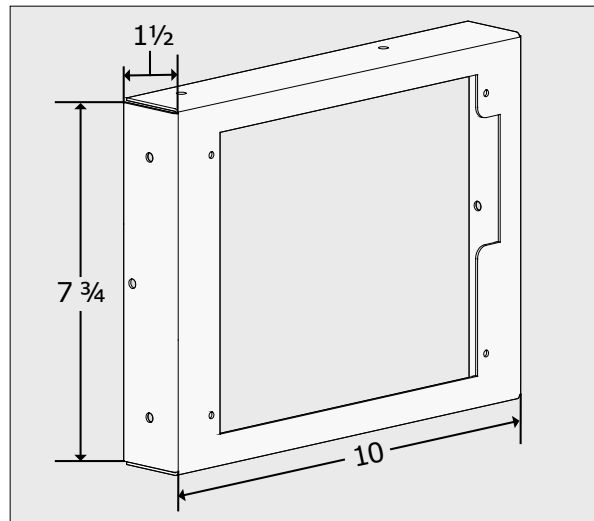

Figure A3-1, Inverter Hood Dimensions

A4 Router Bracket Info



- 1. Dimensions are in inches.
- 2. Material = 16 gauge steel.
- 3. Finish = Powder coat white.
- 4. Weight: 1.5 lbs. (0.7 kg).

Figure A4-1, Router Bracket Dimensions

Appendix A - Optional Equipment and Accessories

Mounting the Router Bracket

The ME-RTR or "router" — which provides parallel capability for the MS-PAE Series inverters — can be easily mounted to the MP enclosure using the Router Bracket kit that comes with the MP enclosure. Figure A4-2 shows the bracket and hardware included in the kit. Figure A4-3 shows the location for mounting the Router bracket. The router bracket can be mounted on the left or right side of the MP enclosure.

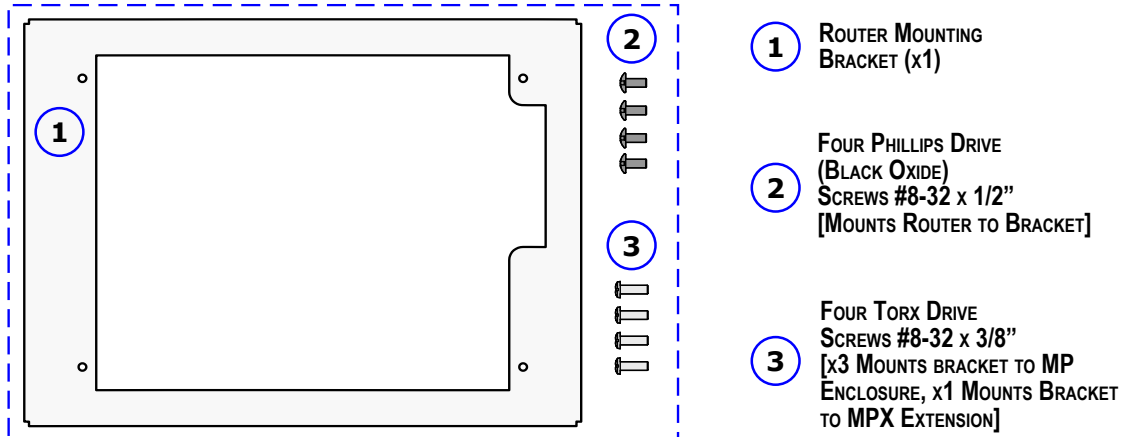

Figure A4-2, Router Bracket Kit

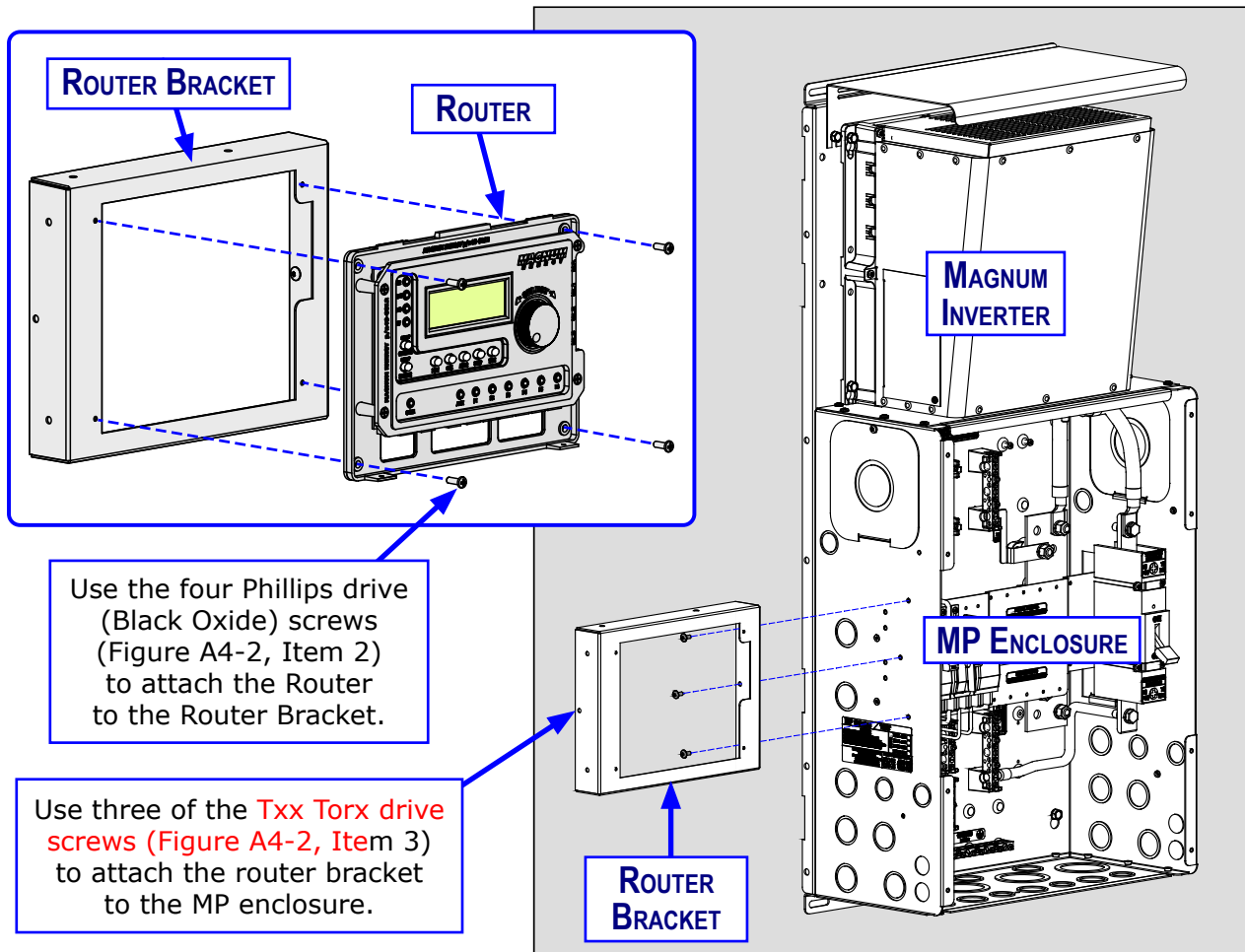

Figure A4-3, Mounting the Router Bracket and Router

A5 Knockout Plate

A Knockout Plate is provided to run conduit from the top of the MP enclosure, or for use as a safety plate. If you are not installing a Magnum inverter into the top of the MP enclosure, then the knockout plate can be used to run conduit from the MP enclosure to another inverter/device. If the Magnum inverter is ever removed for service and the AC bypass breaker is used to continue to power the inverter loads, then the knockout plate can be attached and used as a safety plate to prevent accidental access to live electrical circuits inside the MP enclosure.



WARNING: If the knockout plate is used as a safety plate, the battery cables from the top of the DC disconnect **must be** prevented from touching the metal knockout plate or a short circuit to the battery bank may occur – causing very lethal currents. Either remove these cables or isolate them (i.e., using electrical tape/rubber caps), do not rely ONLY on turning the DC disconnect switch OFF.



Info: Eight #10-32 x 3/8" Pan head, T25 Torx drive, thread cutting screws; and eight #10 lock washers are used to secure the knockout plate to the enclosure.



Info: Before removing the appropriate knockouts, think about whether you are going to use cable clamps, or conduit and all the different wiring required.

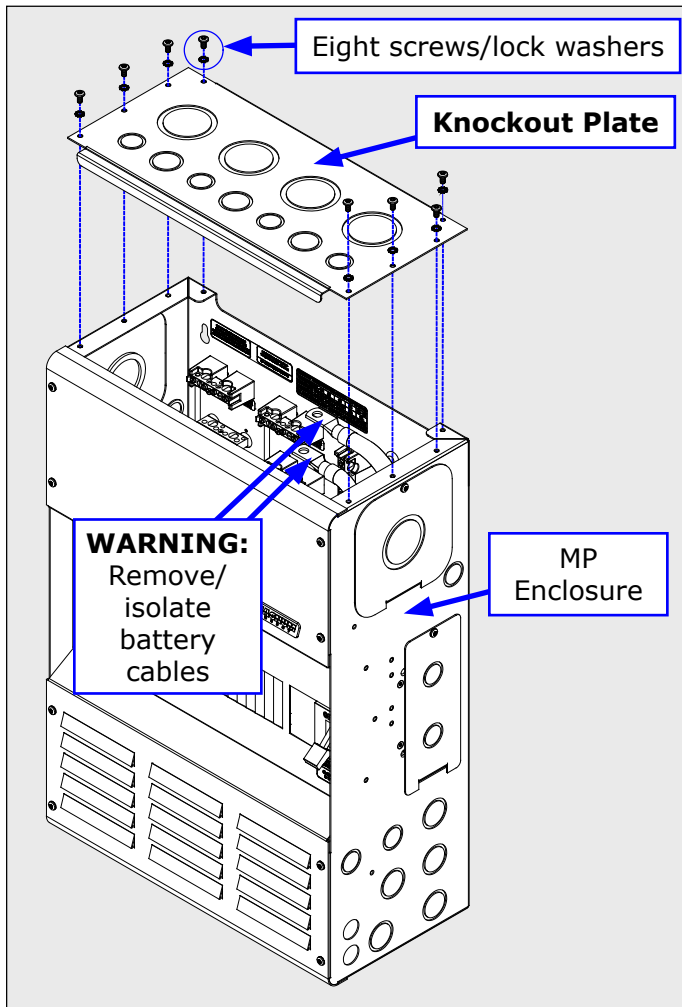

Figure A5-1, Attaching Knockout Plate

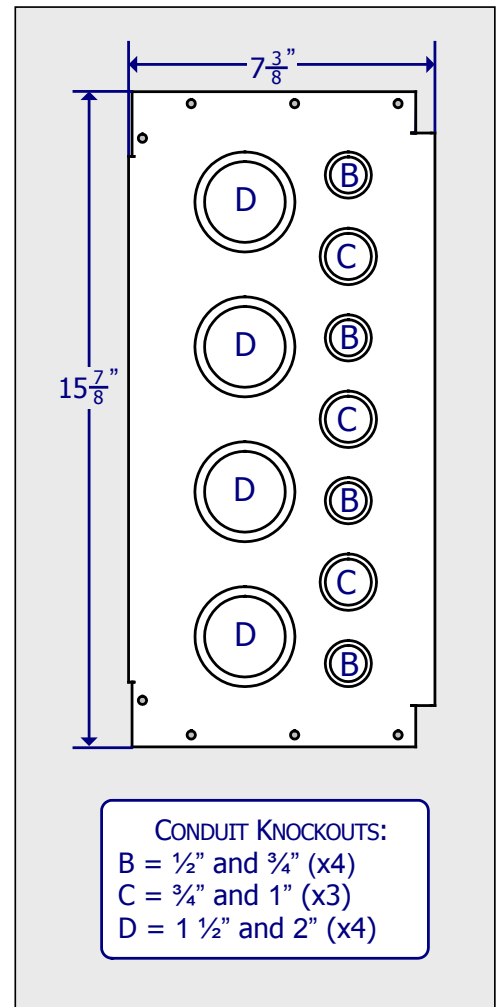

Figure A5-2, Knockout Plate Dimensions and Knockouts

Appendix A - Optional Equipment and Accessories

A6 Installing Optional DC Breakers

The MP5L-30D, MP5L-60S and MP5H-30D enclosures provide the room to install additional DC circuit breakers that may be used for charge controllers, a PV-GFP device, and other DC loads. These enclosure have been specifically designed to allow both back-mounted (1" wide)¹ or DIN rail-mounted (1/2" wide)² breakers.



CAUTION: Turning the inverter DC disconnect breaker off only removes the battery power to the inverter, it does not interrupt power from the battery to the DC load breakers. This must be accomplished by turning off the DC load breakers themselves. Therefore, to shut the system off completely, all of the breakers in the MP enclosure should be switched to the OFF position.

Installation Instructions - DC Load Breakers:

1. Remove the front cover of the MP enclosure.
2. **For DIN rail-mounted breakers** (refer to Figure A6-1):
 - a. Install the breaker(s) on the DIN rail mounting track, and slide them all the way to the left side.
 - b. Place a DIN rail clamp against the right side of the last circuit breaker; and tighten this clamp to secure the breaker(s) on the DIN rail track.
 - c. For each breaker installed, remove only 1 knockout (= 1/2" slot) in the front cover.
3. Ensure the breaker(s) align correctly into the spaces made by the knockouts removed from the front cover (see Section A8).
4. Wire the breaker(s) to the DC circuit (see Figure A6-3).
5. Replace the MP's front cover and check that the breaker operates correctly.

For back-mounted type breakers

(refer to Figure A6-2):

- a. Remove the DIN rail mounting track by unscrewing the #8, Truss head, T15 Torx drive screws.
- b. Secure the breaker(s) to the breaker mounting panel using two #8 screws (minimum 1/2" length).
- c. For each breaker installed, remove only 2 knockouts (= 1" slot) in the front cover.

Note 1 - For the 1/2" wide DIN rail-mounted breakers, use Q-Frame types (QYN Series by CBI).
Note 2 - For the 1" back-mounted breakers, use E-Frame types (E Series by Carling Technologies, 209 Series by Airpax/Sensata Technologies or CF Series by Heinemann/Eaton).

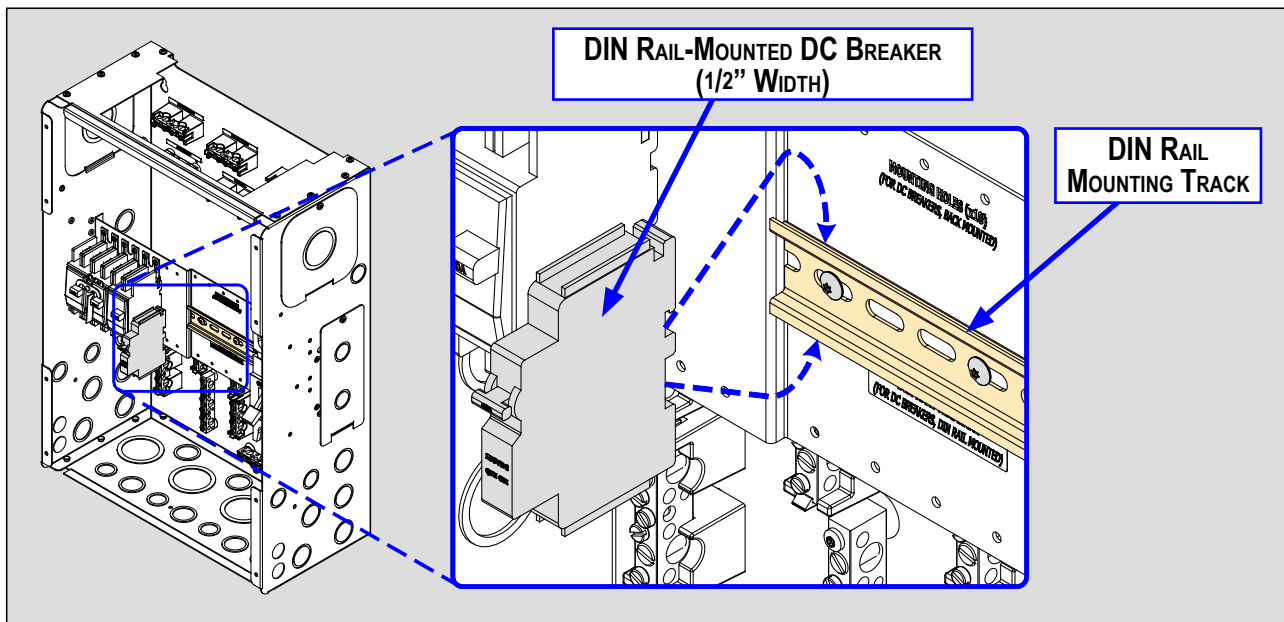

Figure A6-1, Installing DIN Rail-Mounted DC Breakers

Appendix A - Optional Equipment and Accessories

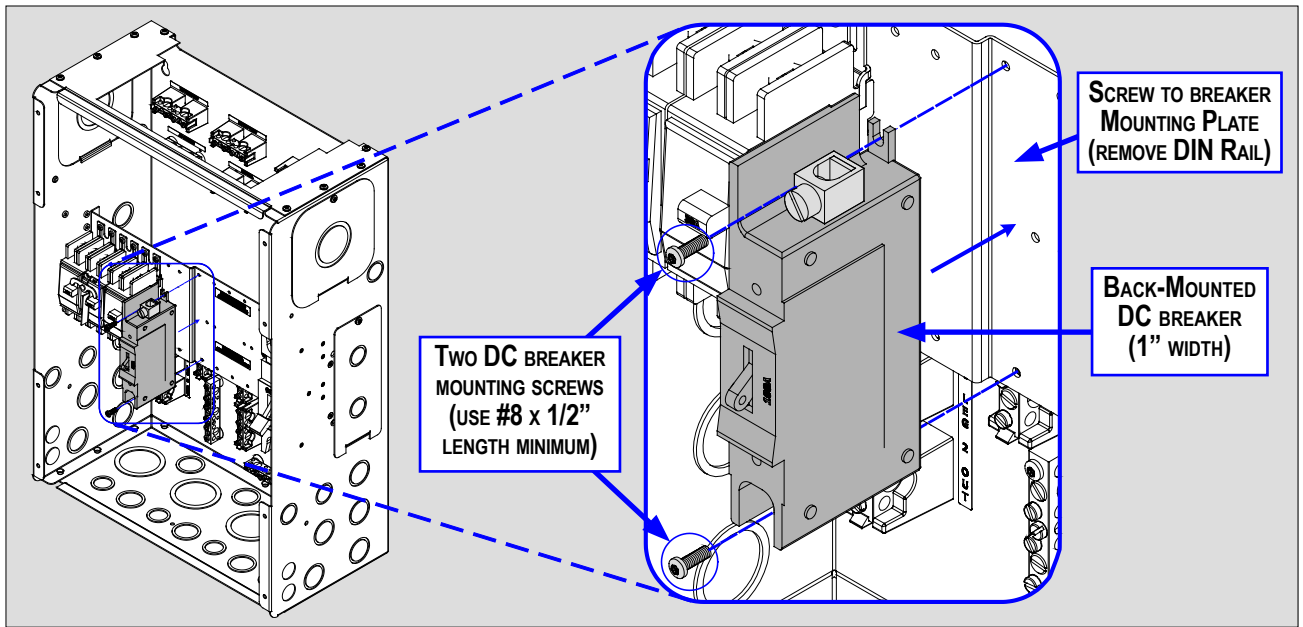

Figure A6-2, Installing Back-Mounted DC Breakers

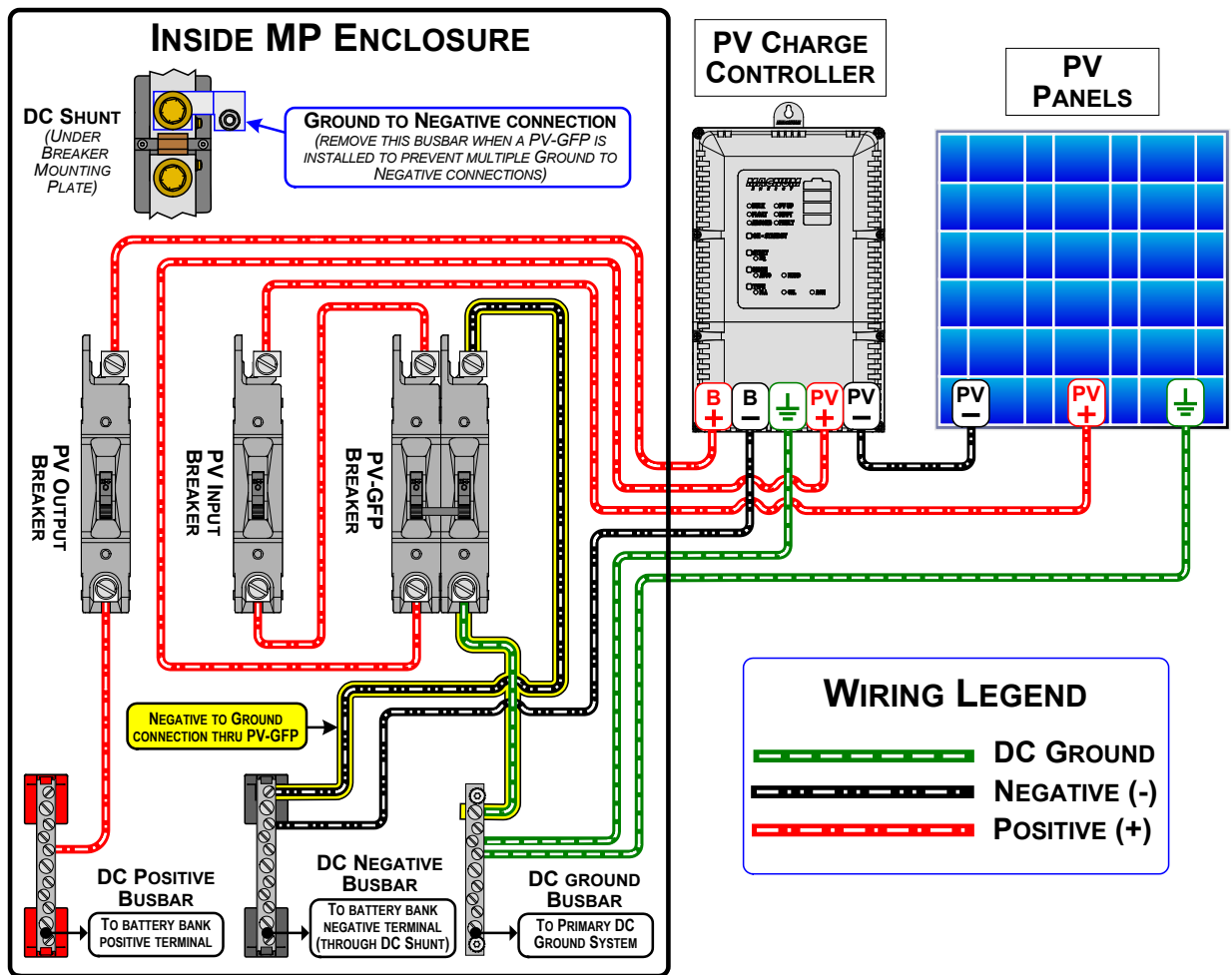

Figure A6-3, Wiring DC Breakers to Controller/PV Array

Appendix A - Optional Equipment and Accessories

A7 Installing Optional AC Load Breakers

If the space is not used by AC inverter input breakers that are required for each installed inverter, additional AC Load breakers — to power inverter loads downstream — can be installed. The MP enclosure has been specifically designed to allow Square-D QOU™ Type back-mounted breakers to be installed. These breakers are found at most electrical stores.

Installation Instructions - AC Load Breakers:

1. While holding the new AC breaker against the MP's mounting plate, align the breaker's four mounting holes with the enclosure's mounting holes (see Figure A7-1). **Note:** The AC breakers are always installed in the left enclosure of a MP dual enclosure (see Figure A7-2).
2. Use four #8-32 x 1/4" screws to hold the AC breaker in place. Do not fully tighten the screws, that will be done in the next step after ensuring proper alignment with the MP enclosure's cover.
3. Check the AC breaker alignment by temporarily placing the MP's front panel cover over the AC breakers. If the fit and alignment are correct, tighten the four screws to secure the new AC breaker.

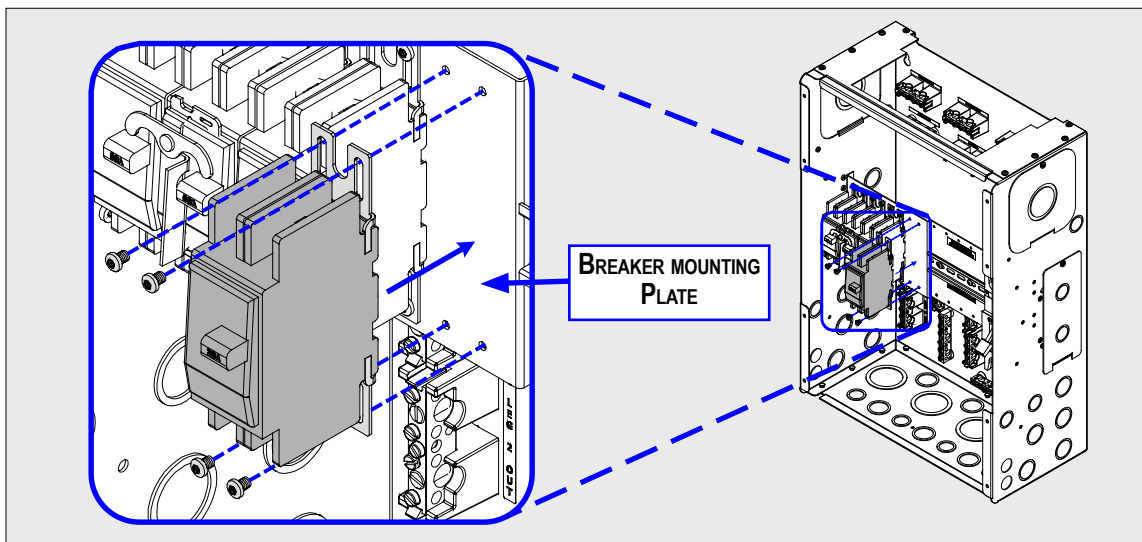

Figure A7-1, Installing AC Load Breakers - Single MP Enclosure

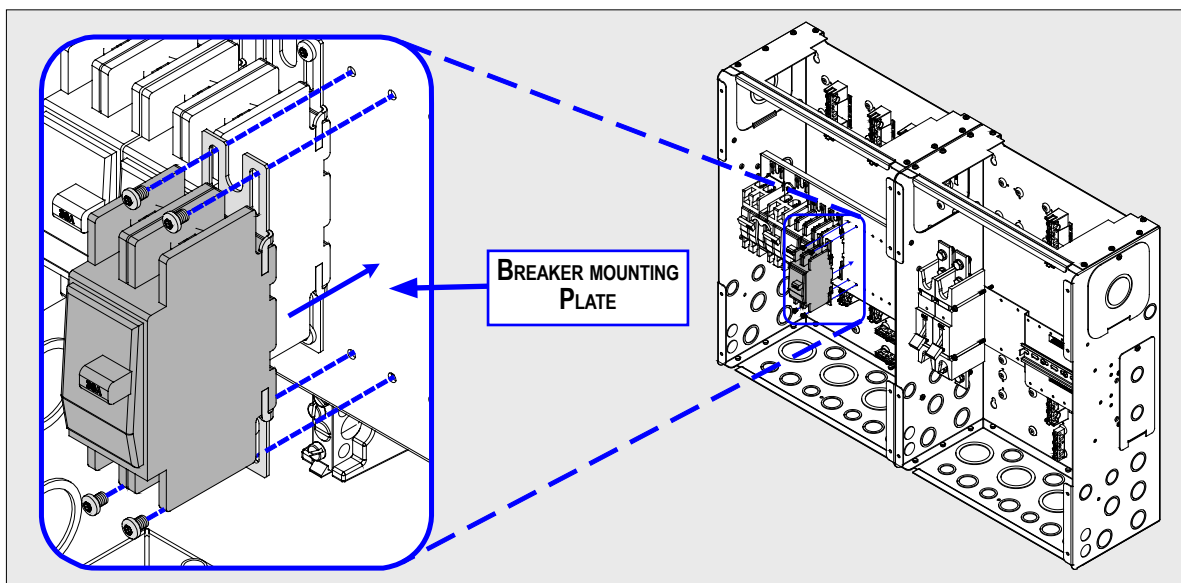

Figure A7-2, Installing AC Load Breakers - Dual MP Enclosure

A8 Aligning Front Breaker Face Plate

On versions of the Magnum Panel that have the eight middle Truss head screws, the front breaker face plate can be adjusted. When additional circuit breakers are installed, the middle eight Truss head, Torx drive (T15) screws can be loosened or removed as shown in Figure A8-1. This allows the knockout openings in the front breaker plate to be aligned around the newly installed circuit breakers. See Figure 3-7 for a front view of the middle eight Truss head screws.



Info: Truss head screws provide a lower-profile dome designed to prevent tampering.

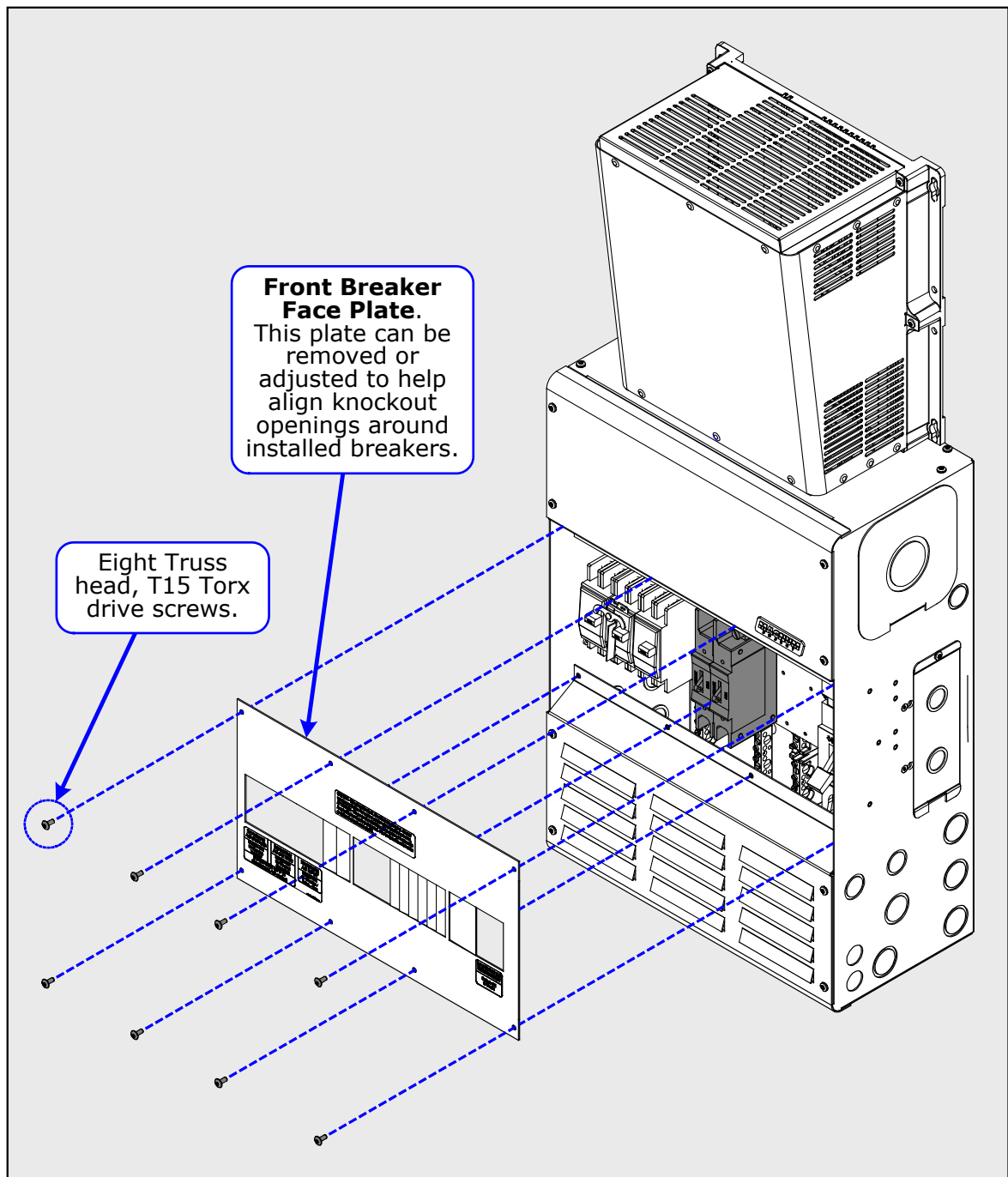

Figure A8-1, Removing the Front Breaker Face Plate

A9 Optional Router Front Top Cover

An optional front top cover (PN: MP-RFC) is available that would replace the factory installed top front cover and allow the ME-RTR (Router) to be installed on the front of the MP enclosure. This optional front top cover is only available for versions of the MP enclosure that have the middle eight truss head screws (see Figure 3-7).

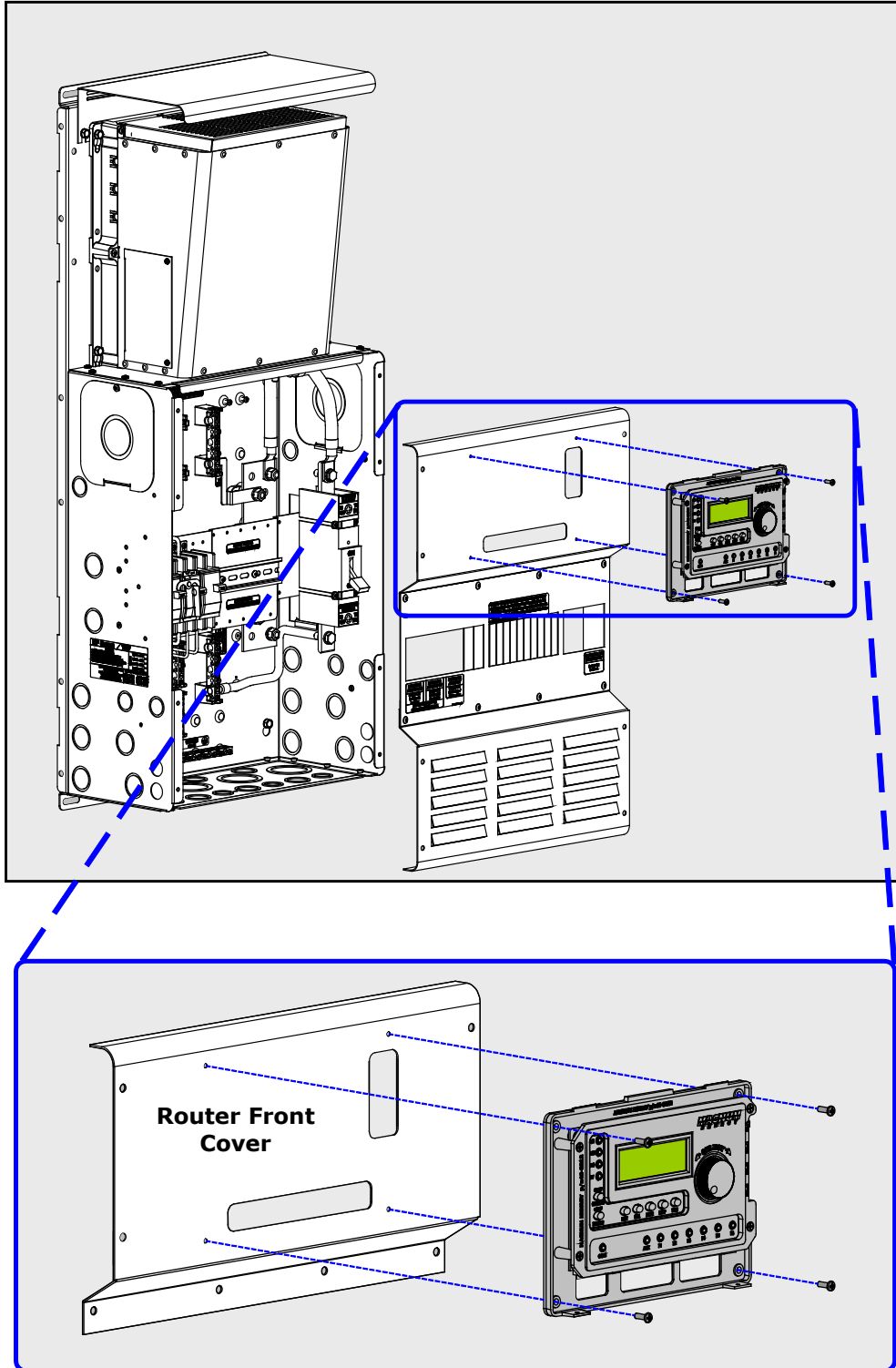

Figure A9-1, Router Front Top Cover

A10 Installing Lightning Arrestors

Unfortunately, in Renewable Energy (RE) systems where components are wired to outdoor electrical systems, there is a greater chance of damage to components from lightning strikes. Lightning does not have to strike directly to cause damage, it can be far away and still induce power surges or spikes in the wires of the RE system. Since the RE wires are connected to the conductors coming into the house, the inverters, charge controllers, batteries, and other components in the house or power shed are easily susceptible to damage.

The best line of defense against these high voltage surges — caused by lightning — is to ensure you have proper system grounding. Proper grounding attempts to divert lightning surges to earth, instead of going through your electrical components. However, for additional protection in lightning-prone areas or where good grounding is not feasible, install lightning arrestors (also known as high voltage surge arrestors) on the DC and AC circuits of your renewable energy system. Lightning arrestors are devices that respond to voltage variations instantaneously, effectively intercepting potentially damaging spikes and surges and reducing them to acceptable power levels to protect electrical equipment. Metal Oxide Varistors (MOVs), Silicone Oxide Varistors (SOVs), and Zinc Oxide Non-Linear resistors (ZNRs) are three types of lightning/surge arrestors.

The most readily available lightning arrestors in the marketplace install into 1/2" conduit knockouts. Since the MP enclosure is the central connection point for the main AC and DC electrical components of the renewable energy system, multiple 1/2" knockouts are provided to allow these lightning arrestors to be easily installed. The lightning arrestors should be connected as close to the equipment you are trying to protect as possible. Review Figure A10-1 for help installing these lightning arrestors, and use Figure A10-2 for assistance on wiring lightning arrestors on the DC and AC circuits inside the MP enclosure.



Info: Install additional lightning protection (secondary lightning arrestor) if equipment is more than 60 ft. away from where the primary lightning arrestor is connected.



Info: For more information on lightning protection in RE systems, review *Protection Against the Effects of Lightning on Stand-Alone Photovoltaic Systems - Common Practices* at www.iea-pvps.org.

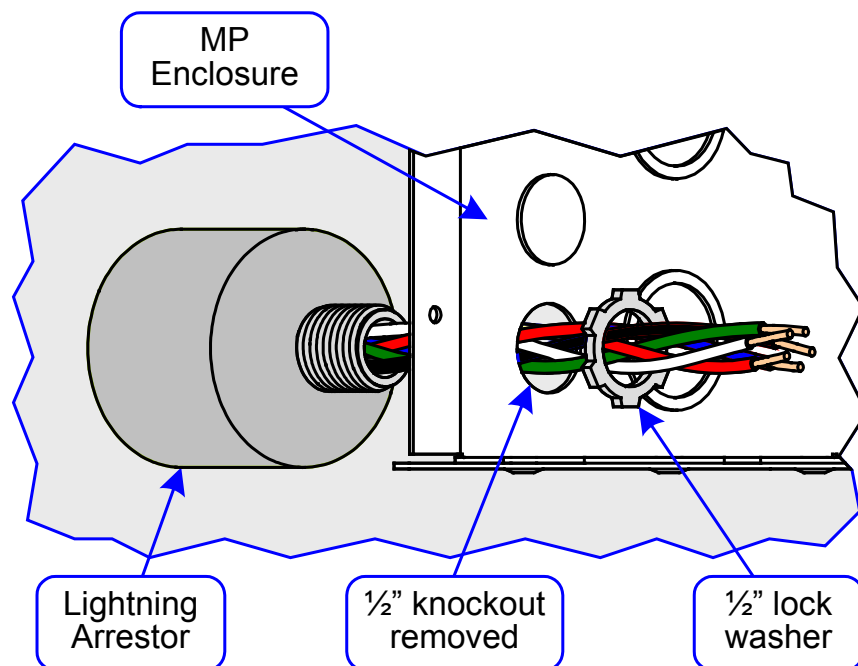

Figure A10-1, Installing Lightning Arrestor on MP Enclosure

Appendix A - Optional Equipment and Accessories

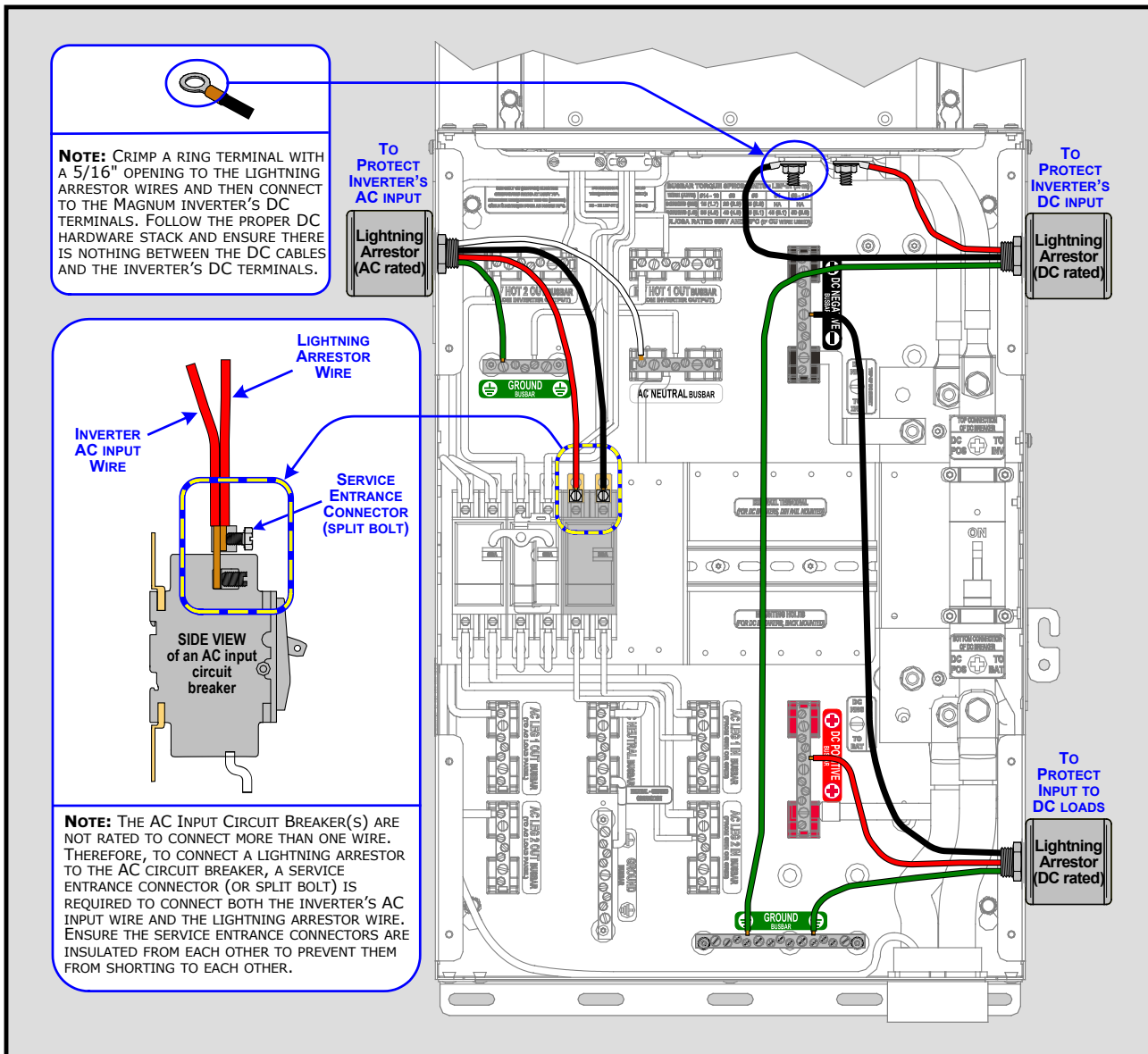

Figure A10-2, Wiring Lightning Arrestor to MP Enclosure



Info: Make sure enough insulation is stripped so that the inverter's AC input wire is fully inserted in the AC terminal block and enough uninsulated wire is still available to contact with the lightning arrestor wire, when using a service entrance connector.



Info: Some readily used service entrance connectors are the Type SX manufactured by IlSCO (www.ilsco.com), or the Type N manufactured by Thomas and Betts (www.tnb.com).

Appendix B - Warranty and Service

B1 Limited Warranty

Magnum Energy, Inc., warrants the Magnum Panel to be free from defects in material and workmanship that result in product failure during normal usage, according to the following terms and conditions:

1. The limited warranty for the product extends for 12 months beginning from the product's original date of purchase.
2. The limited warranty extends to the original purchaser of the product and is not assignable or transferable to any subsequent purchaser.
3. During the limited warranty period, Magnum Energy will repair, or replace at Magnum Energy's option, any defective parts, or any parts that will not properly operate for their intended use with factory new or remanufactured replacement items if such repair or replacement is needed because of product malfunction or failure during normal usage. The limited warranty does not cover defects in appearance, cosmetic, decorative or structural parts or any non-operative parts. Magnum Energy's limit of liability under the limited warranty shall be the actual cash value of the product at the time the original purchaser returns the product for repair, determined by the price paid by the original purchaser. Magnum Energy shall not be liable for any other losses or damages.
4. Upon request from Magnum Energy, the original purchaser must prove the product's original date of purchase by a dated bill of sale, itemized receipt.
5. The original purchaser shall return the product prepaid to Magnum Energy in Everett, WA. After the completion of service under this limited warranty, Magnum Energy will return the product prepaid to the original purchaser via a Magnum-selected non-expedited surface freight within the contiguous United States and Canada; this excludes Alaska and Hawaii.
6. This limited warranty is voided if:
 - the product has been modified without authorization;
 - the product label and/or serial number label has been altered, defaced or removed;
 - the product has been damaged from abuse, neglect, accident, high voltage or corrosion;
 - the product was not installed and operated according to the owner's manual.

B2 How to Receive Repair Service

If your product requires warranty service or repair, contact either:

1. An Authorized Service Center, which are listed on the Magnum Energy website at www.magnumenergy.com/ServiceCenters-US.htm, or
2. Magnum Energy, Inc. at:
 - Telephone: 425-353-8833
 - Fax: 425-353-8390
 - Email: http://warranty@magnumenergy.com

If returning the product directly to Magnum Energy for repair, you must:

- Return the unit in the original, or equivalent, shipping container.
Note: Damage from shipping is not covered under warranty, ensure the unit is properly packaged.
- Receive a Return Materials Authorization (RMA) number from the factory prior to the return of the product to Magnum Energy for repair.
- Place RMA numbers clearly on the shipping container or on the packing slip.

**BEFORE RETURNING ANY UNIT TO MAGNUM ENERGY INC.,
A RETURN MATERIAL AUTHORIZATION (RMA) NUMBER IS REQUIRED.**



Magnum Energy, Inc.
2211 West Casino Rd.
Everett, WA 98204
Phone: 425-353-8833
Fax: 425-353-8390
Web: www.magnumenergy.com